

FCI-D03A4-NAEX-H1141/M12

Flow Monitoring – Inline Sensor with Separate Processor

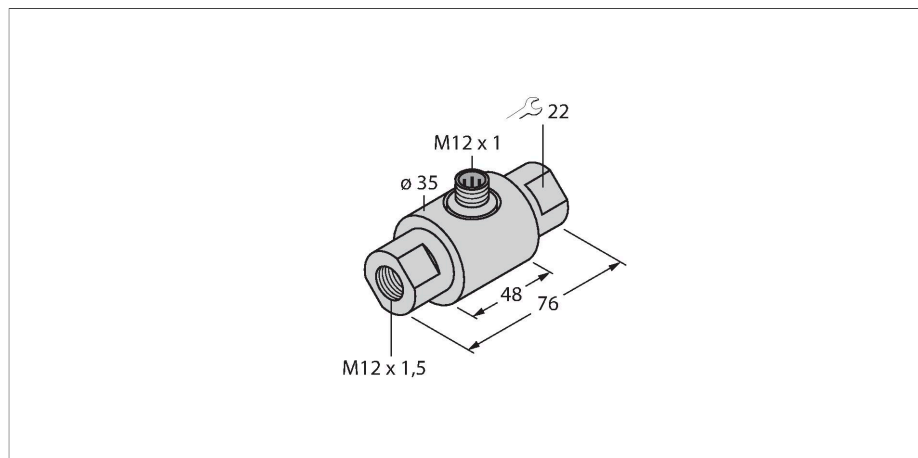

Features

- Intrinsically safe flow sensor for liquid media
- Calorimetric principle
- Adjustment via potentiometer located on the intrinsically safe processor
- Status indicated via LED chain on Ex signal processor
- Intrinsically safe Ex ib IIC T6, for use in zone 1
- Connector device, M12 x 1
- 4-wire connection to an Ex0 processor
- ATEX category II 2 G, Ex zone 1

Wiring diagram

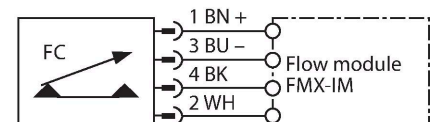

Functional principle

The function of the inline flow sensors is based on the thermo-dynamic principle. Heat is generated in a measuring tube and absorbed by the flowing medium. The transported heat loss is thus a measure of the flow speed. Thus TURCK's wear-free flow sensors reliably monitor the flow of gaseous and liquid media. A low pressure drop and fast response to flow rate variations are the outstanding features of these devices.

Technical data

Ident. no.	6870632
Type	FCI-D03A4-NAEX-H1141/M12
Mounting conditions	Inline sensor
Flow operating range	0,01...0,15 l/min
Stand-by time	typ. 8 s (2...15 s)
Switch-on time	typ. 2 s (1...15 s)
Switch-off time	typ. 2 s (1...15 s)
Temperature jump, response time	max. 12 s
Temperature gradient	≤ 250 K/min
Medium temperature	-20...+70 °C
Device marking	Ⓔ II 2 G EEx ib IIC T6
Ignition protection category	Ex ib IIC
Power	≤ 0.69 W
Internal inductances/capacitances	negligibly small
Ex approval acc. to conformity certificate	TÜV 96 ATEX 1101
Protection class	IP67
Design	Inline
Housing material	Stainless steel, V4A (1.4571)
Sensor material	Stainless steel, V4A (1.4571)
Electrical connection	Connectors, M12 x 1
Pressure resistance	6 bar
Process connection	M12 x 1,5

Operating Instructions

Intended use

This device fulfills the directive 2014/34/EC and is suited for use in explosion hazardous areas according to EN60079-0:2006, -11:2007, -26:2004 and EN61241-0:2006, -11:2006. In order to ensure correct operation to the intended purpose it is required to observe the national regulations and directives.

For use in explosion hazardous areas conform to classification

II 2 G (Group II, Category 2 G, electrical equipment for gaseous atmospheres).

Marking (see device or technical data sheet)

⊕ II 2 G and EEx ib IIC T6 acc.to EN50020

Installation/Commissioning

These devices may only be installed, connected and operated by trained and qualified staff. Qualified staff must have knowledge of protection classes, directives and regulations concerning electrical equipment designed for use in explosion hazardous areas. Please verify that the classification and the marking on the device comply with the actual application conditions.

This device is only suited for connection to approved Exi circuits according to EN 60079-0 and EN 60079-11. Please observe the maximum admissible electrical values. After connection to other circuits the sensor may no longer be used in Exi installations. When interconnected to (associated) electrical equipment, it is required to perform the "Proof of intrinsic safety" (EN60079-14).

Installation and mounting instructions

Avoid static charging of cables and plastic devices. Please only clean the device with a damp cloth. Do not install the device in a dust flow and avoid build-up of dust deposits on the device. If the devices and the cable could be subject to mechanical damage, they must be protected accordingly. They must also be shielded against strong electro-magnetic fields. The pin configuration and the electrical specifications can be taken from the device marking or the technical data sheet. In order to avoid contamination of the device, please remove possible blanking plugs of the cable glands or connectors only shortly before inserting the cable or opening the cable socket.

Special conditions for safe operation

The device must be protected against any kind of mechanical damage.

Service/Maintenance

Repairs are not possible. The approval expires if the device is repaired or modified by a person other than the manufacturer. The most important data from the approval are listed.