

4/3 directional control valve, pilot operated, with electric position feedback and integrated electronics (OBE)

RE 29077/03.10
Replaces: 01.09

1/16

Type 4WRVE 10...27, symbols V, V1

Sizes 10, 16, 25, 27

Component series 2X

Maximum operating pressure P, A, B 350 bar (size 27: 280 bar)

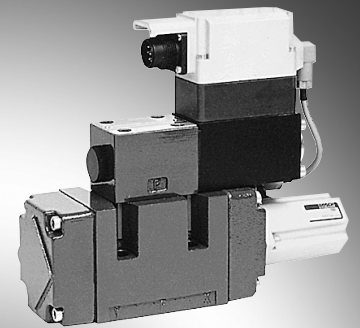
Rated flow 40...430 l/min ($\Delta p = 10$ bar)

Type 4WRVE 10

Table of contents

| Contents | Page |
|-------------------------------|----------|
| Features | 1 |
| Ordering code | 2 |
| Function, section | 3 |
| Symbols | 4 |
| Test and service devices | 4 |
| Technical data | 5 and 6 |
| Electrical connection | 7 |
| Technical notes for the cable | 7 |
| Integrated electronics | 8 |
| Characteristic curves | 9 to 11 |
| Unit dimensions | 12 to 14 |

Features

- Pilot operated high-response 4/3 directional control valve size 10 to size 27, with control spool and bushing in servo quality
- Integrated electronics (OBE) with position controller for pilot control and main stage, calibrated in the factory
- Main stage in servo quality with position feedback
- Flow characteristics
 - M = progressive with fine control edge
 - P = inflected characteristic curve
 - L = linear
- Electric port 11P+PE
Differential amplifier signal input with interface B5 ±10 V

Information on available spare parts:
www.boschrexroth.com/spc

Ordering code

| | | | | | | | | | | | |
|------|---|--|--|--|-----|-----|--|----|----|---|---|
| 4WRV | E | | | | -2X | G24 | | K0 | B5 | M | * |
|------|---|--|--|--|-----|-----|--|----|----|---|---|

with **integrated** electronics = E

Size = 10
 = 16
 = 25
 = 27¹⁾

Control spool symbols

4/3 directional design

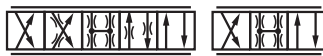
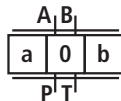

= V, V1

For V1:

P → A: q_v B → T: $q_v/2$
 P → B: $q_v/2$ A → T: q_v

Rated flow

at 10 bar valve pressure differential
 (5 bar/control edge)

Size 10

40 l/min²⁾ = 40
 55 l/min³⁾ = 55
 70 l/min²⁾ = 70
 85 l/min³⁾ = 85

Size 16

90 l/min²⁾ = 90
 120 l/min³⁾ = 120
 150 l/min²⁾ = 150
 200 l/min³⁾ = 200

Size 25

300 l/min²⁾ = 300
 370 l/min³⁾ = 370

Size 27

430 l/min^{1) 3)} = 430

¹⁾ Size 27 is the high-flow version of size 25, the connection bores P, A, B, T are designed with Ø32 mm in the main stage. In the manifold, ports P, A, B, T can be drilled with max. Ø30 mm in deviation from standard ISO 4401-08-08-0-05. Thus, the valves allow for higher flow values $Q_A : Q_B$

²⁾ Q_N : Flow characteristics "P"

³⁾ Q_N : Flow characteristics "M" or "L"

Further details in the plain text

Seal material

M = NBR seals suitable for mineral oils (HL, HLP) according to DIN 51524

Interface of the control electronics

B5 = Command value input ±10 V

Electrical connection

K0 = without mating connector, with unit connector according to DIN 43563-AM6
 Mating connector – separate order

Pilot oil supply "x", pilot oil return "y"

No code = "x" = external, "y" = external
 E = "x" = internal, "y" = external
 ET = "x" = internal, "y" = internal
 T = "x" = external, "y" = internal

Supply voltage of the electronics

G24 = +24 V direct current

2X = Component series 20 to 29 (unchanged installation and connection dimensions)

Flow characteristics

M = Progressive with linear fine control (up to 20%)
 P = Inflected characteristic curve, linear (inflection at 40%)
 L = Linear

Function, section

Structure

The valve consists of 3 main assemblies:

- Pilot control valve (1) with control spool and bushing, return springs, double stroke solenoid and inductive position transducer
- Main stage (2) with centering springs and position feedback
- Integrated control electronics (3)

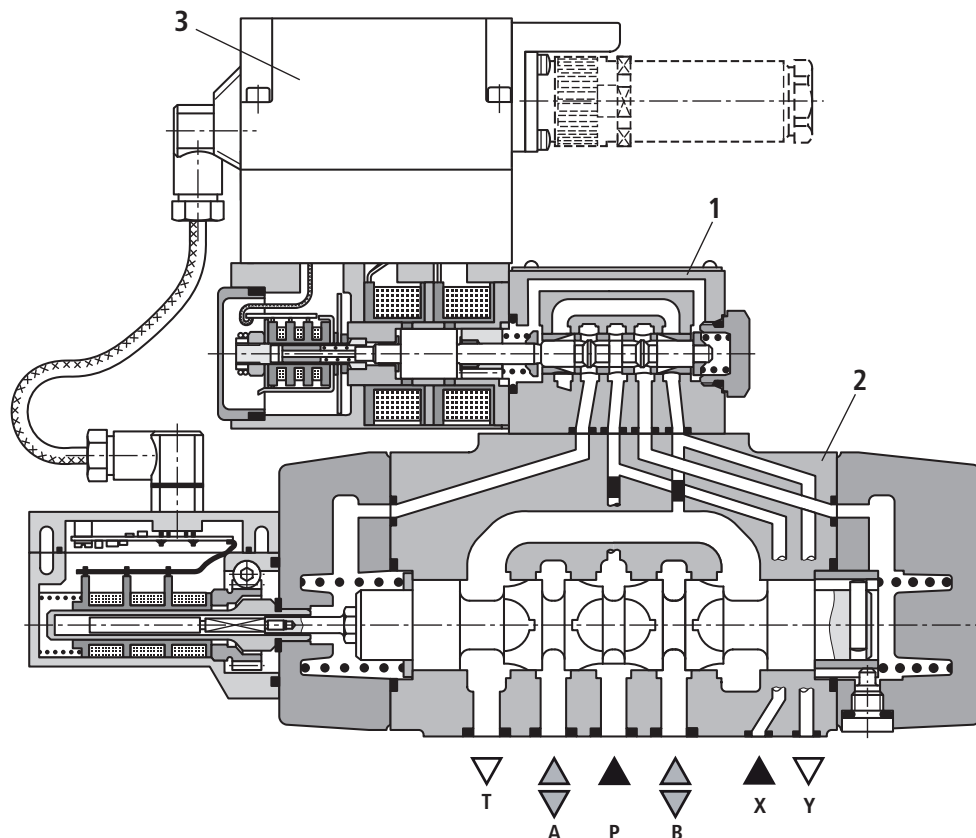

Functional description

In the integrated electronics, the specified command value is compared with the actual position value of the main stage control spool. In case of control deviations, the double stroke solenoid is activated which adjusts the pilot control spool due to the changed magnetic force. The flow released through the control cross-sections causes the displacement of the main control spool, the stroke/control cross-section of which is controlled proportionally to the command value. If the command value is 0 V, the electronic controls the control spool of the main stage in the center position.

The pilot control valve is supplied with the pilot oil either internally through port P or externally through port X. The return to the tank can be implemented internally via port T or externally via port Y.

If deactivated or in case of no release, the pilot control valve is undefined in P-B/A-T (preferred) or P-A/B-T, the main stage can be completely controlled.

Symbols

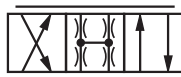
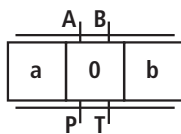

Type ...-3X...

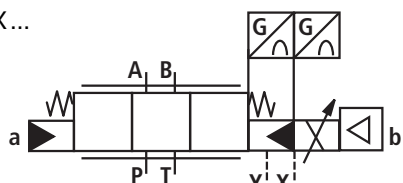

Type ...-3X...E...

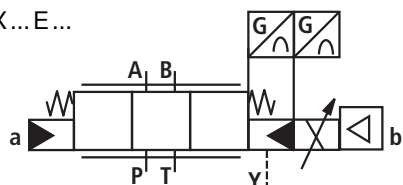

Type ...-3X...ET...

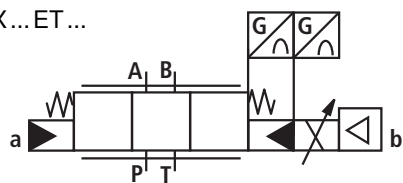

Type ...-3X...T...

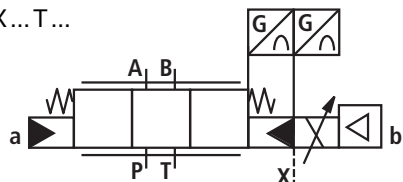

Symbol, detailed
(pilot oil supply and pilot oil drain external)

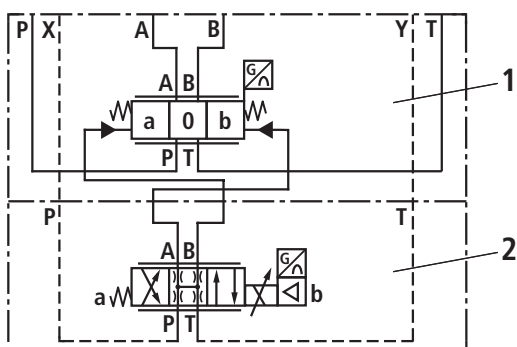

1 Main valve
2 Pilot control valve

Test and service devices

- Type VT-VETSY-1 service case with test device, see RE 29685
- Measuring adapter 11P+PE type VT-PA-1, see RE 30067

Technical data

| general | | | | | | | | | | | | | |
|---|--|-------------------------|----------|----------------|------|----------------|------|----------------|------|----------------|-----|----------------|-----|
| Type | Spool valve, pilot operated | | | | | | | | | | | | |
| Actuation | Directional control valve size 6 - OBE, with position controller for pilot control valve and main stage | | | | | | | | | | | | |
| Type of connection | Subplate mounting, porting pattern according to ISO 4401-... | | | | | | | | | | | | |
| Installation position | Any | | | | | | | | | | | | |
| Ambient temperature range | °C | -20...+50 | | | | | | | | | | | |
| Weight | kg | Size 10 | 8.0 | Size 16 | 10.4 | Size 25 | 18.2 | Size 27 | 18.2 | | | | |
| Vibration resistance, test condition | Max. 25 g, room vibration test in all directions (24 h) | | | | | | | | | | | | |
| hydraulic (measured with HLP 46, $\vartheta_{oil} = 40 \text{ °C} \pm 5 \text{ °C}$) | | | | | | | | | | | | | |
| Hydraulic fluid | Hydraulic oil according to DIN 51524...535, other media upon request | | | | | | | | | | | | |
| Viscosity range | recommended | mm ² /s | 20...100 | | | | | | | | | | |
| | max admissible | mm ² /s | 10...800 | | | | | | | | | | |
| Hydraulic fluid temperature range | °C | -20...+65 | | | | | | | | | | | |
| Maximum admissible degree of contamination of the hydraulic fluid cleanliness class according to ISO 4406 (c) | Class 18/16/13 ¹⁾ | | | | | | | | | | | | |
| Flow direction | According to symbol | | | | | | | | | | | | |
| Rated flow at $\Delta p = 5 \text{ bar per edge}^2)$ | l/min | Size 10 | | | | Size 16 | | | | Size 25 | | Size 27 | |
| | | 40 | 55 | 70 | 85 | 90 | 120 | 150 | 200 | 300 | 370 | 430 | |
| Max. operating pressure | Ports P, A, B external pilot oil supply | bar | 350 | | | | 350 | | | | 350 | | 350 |
| | Ports P, A, B internal pilot oil supply | bar | | | | | 250 | | | | | | |
| | Ports T, X, Y | bar | | | | | 250 | | | | | | |
| Min. pilot oil pressure "pilot control stage" | bar | 10 | | | | | | | | | | | |
| Q_{max} | l/min | 170 | | | | 450 | | | | 900 | | 1000 | |
| Q_N pilot control valve | l/min | 8 | | | | 24 | | | | 40 | | 40 | |
| Zero flow pilot control valve at 100 bar | cm ³ /min | < 180 | | | | < 300 | | | | < 500 | | < 500 | |
| Zero flow main stage at 100 bar | cm ³ /min | < 400 | < 600 | | | < 1000 | | | | < 1000 | | < 1000 | |
| static / dynamic | | | | | | | | | | | | | |
| Hysteresis | % | < 0.1 hardly measurable | | | | | | | | | | | |
| Manufacturing tolerance Q_{max} | % | < 10 | | | | | | | | | | | |
| Actuating time for signal step (at X = 100 bar) | 0...100% | 12 | | | | 15 | | | | 23 | | 23 | |
| | 0...10% | 6 | | | | 7 | | | | 10 | | 10 | |
| Actuating time for signal step (at X = 10 bar) | 0...100% | 40 | | | | 50 | | | | 90 | | 90 | |
| | 0...10% | 20 | | | | 20 | | | | 30 | | 30 | |
| Switch-off behavior | after electrical shut-off: Pilot control valve not defined in P-B/A-T or P-A/B-T, main stage can be completely controlled (PB/AT or PA/BT) | | | | | | | | | | | | |
| Temperature drift | Zero shift < 1% at $\Delta T = 40 \text{ °C}$ | | | | | | | | | | | | |
| Zero compensation | ex factory $\pm 1 \%$ | | | | | | | | | | | | |

¹⁾ The cleanliness classes specified for the components must be complied with in hydraulic systems. Effective filtration prevents faults and at the same time increases the service life of the components. For the selection of the filters, see technical data sheets RE 50070, RE 50076 and RE 50081.

²⁾ Flow with different Δp $Q_x = Q_{nom} \cdot \sqrt{\frac{\Delta p_x}{5}}$

Technical data

| electric , control electronics integrated in the valve | | | | |
|---|---|---|--|---|
| Relative duty cycle | % | 100 ED, max. power consumption 30 VA (24 V=) | | |
| Protection class | | IP 65 according to DIN 40050 | | |
| Port | Plug-in connector, 11P+PE | Data | | |
| Supply 24 V _{=nom} ¹⁾ | 2) <table border="1" style="display: inline-table; vertical-align: middle;"><tr><td>1</td></tr><tr><td>2</td></tr></table> | 1 | 2 | +24 V _{=nom} , fuse protection 2.5 A _F (output stages) 0 V power ground |
| | 1 | | | |
| 2 | | | | |
| 3) <table border="1" style="display: inline-table; vertical-align: middle;"><tr><td>9</td></tr><tr><td>10</td></tr></table> | 9 | 10 | +24 V _{=nom} Signal part 0 V Signal ground | |
| 9 | | | | |
| 10 | | | | |
| Input signal ±10 V | 4) <table border="1" style="display: inline-table; vertical-align: middle;"><tr><td>4</td></tr><tr><td>5</td></tr></table> | 4 | 5 | $\left. \begin{matrix} U_{IN} \\ \overline{U}_{IN} \end{matrix} \right\}$ Differential amplifier, $R_i = 100 \text{ k}\Omega$ |
| 4 | | | | |
| 5 | | | | |
| Actual value signal (LVDT) | <table border="1" style="display: inline-table; vertical-align: middle;"><tr><td>6</td></tr><tr><td>7</td></tr></table> | 6 | 7 | ±10 V ₌ , $R_a = 1 \text{ k}\Omega$ 0 V, reference point |
| 6 | | | | |
| 7 | | | | |
| Release input | <table border="1" style="display: inline-table; vertical-align: middle;"><tr><td>3</td></tr></table> | 3 | > 8.5 V to 24 V _{=nom} (max. 40 V=) $R_i = 10 \text{ k}\Omega$ | |
| 3 | | | | |
| Messages | 5) <table border="1" style="display: inline-table; vertical-align: middle;"><tr><td>8</td></tr><tr><td>11</td></tr></table> | 8 | 11 | Acknowledgement release +24 V= Error message: no error +24 V= |
| 8 | | | | |
| 11 | | | | |
| Protective earthing conductor |  | Connect only if 24 V = system transformer does not comply with standard VDE 0551 | | |
| Electromagnetic compatibility tested according to | | EN 61000-6-2: 2005-08 EN 61000-6-3: 2007-01 | | |

1) 24 V_{=nom} – min. 21 V=
– max. 40 V=

2) U_B (pin 1) = output stage supply
– valve "OFF" < 13.4 V=
– valve "ON" > 16.8 V=
no error message (pin 11)

3) U_S (pin 9) = electronics supply
– valve "OFF" < 16.8 V=
error message (pin 11)
– valve "ON" > 19.5 V=
no error message (pin 11)

4) inputs: voltage resistant up to max. 50 V

5) Messages are loadable with max. 20 mA
and short-circuit proof against ground

11P+PE

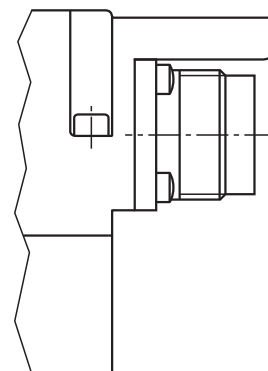
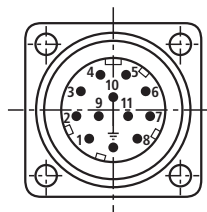

Note

Pilot operated 4/3 directional control valves fulfill their function only in active closed control loops and do not have a secured basic position when deactivated. Therefore, "additional isolator valves" are required in many applications and must be taken into account for the On/Off series.

Electrical connection

Electric data, see page 6

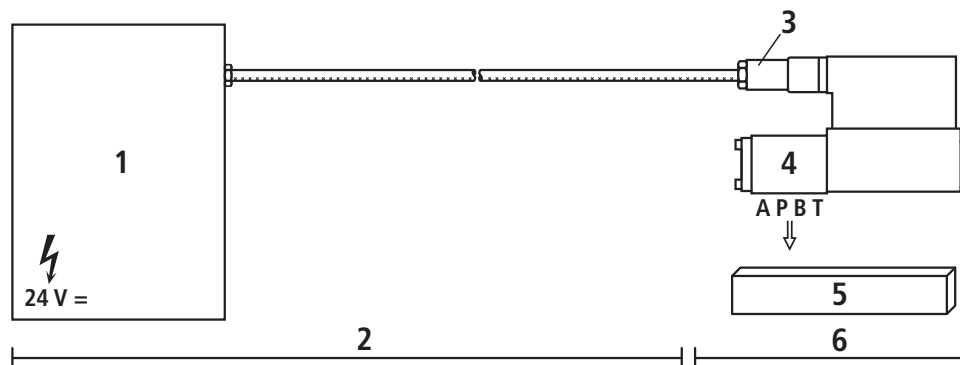

- 1 Control
- 2 Provided by the customer
- 3 Mating connector
- 4 Valve
- 5 Contact surface
- 6 Provided by Rexroth

Technical notes for the cable

- Version:**
- Multi-wire cable
 - Litz wire structure, very fine wires according to VDE 0295, class 6
 - Protective earthing conductor, green-yellow
 - Cu shield braid
- Type:**
- e.g. Oilflex-FD 855 CP (company Lappkabel)
- Number of wires:**
- Depends on the valve type, connector type and signal assignment
- Line Ø:**
- 0.75 mm² up to a length of 20 m
 - 1.0 mm² up to a length of 40 m
- Outer Ø:**
- 9.4...11.8 mm – Pg11
 - 12.7...13.5 mm – Pg16

Note

Electric signals taken out via control electronics (e.g. actual value) must not be used for the deactivation of safety-relevant machine functions!
(See also the European standard "Safety requirements for fluid power systems and their components - Hydraulics", EN 982!)

Integrated electronics

Block diagram/Pinout

version B5: $U_E \pm 10\text{ V}$

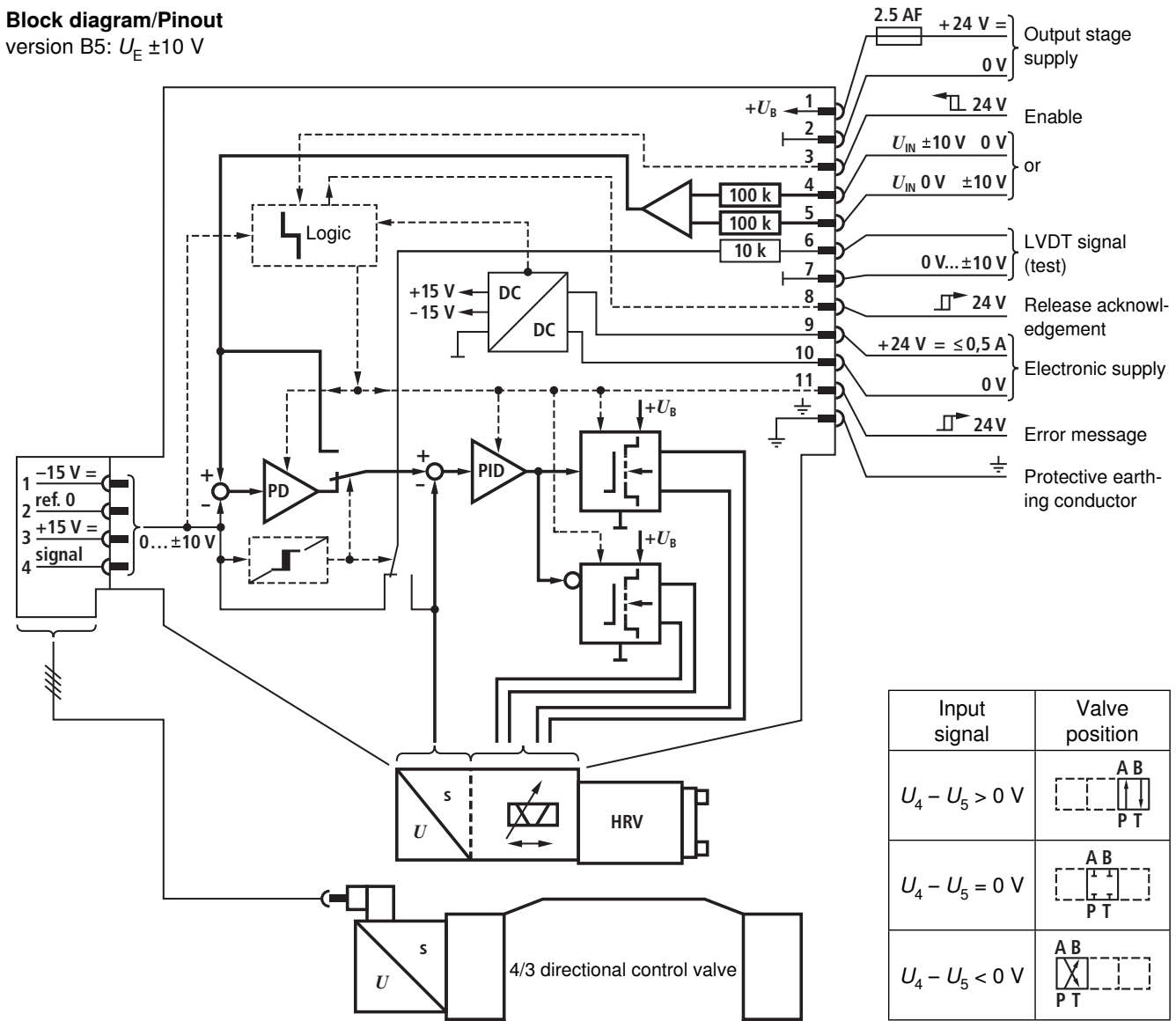

| Input signal | Valve position |
|--------------------------|----------------|
| $U_4 - U_5 > 0\text{ V}$ | |
| $U_4 - U_5 = 0\text{ V}$ | |
| $U_4 - U_5 < 0\text{ V}$ | |

Pin assignment 11P+PE

version B5: $U_E \pm 10\text{ V}$

($R_i = 100\text{ k}\Omega$)

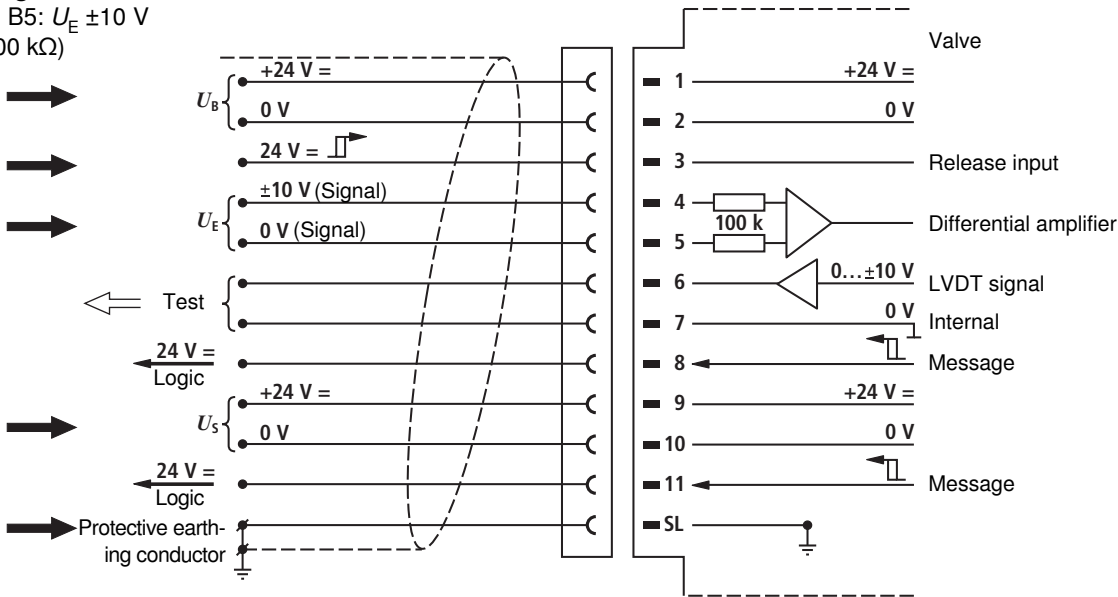

Characteristic curves (measured with HLP 46, $\vartheta_{Oil} = 40 \text{ }^\circ\text{C} \pm 5 \text{ }^\circ\text{C}$)

Flow – signal function $Q = f(U_E)$

Flow characteristics M

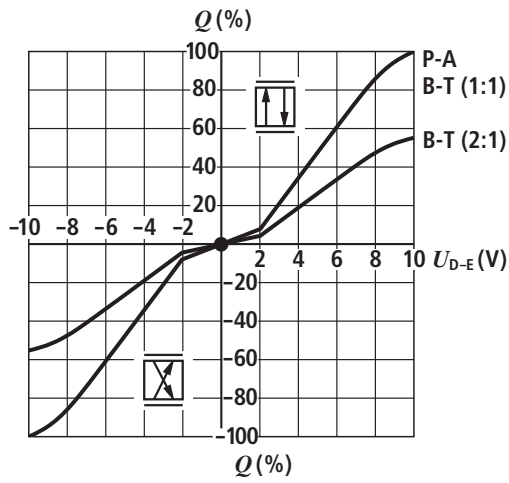

Flow characteristics P

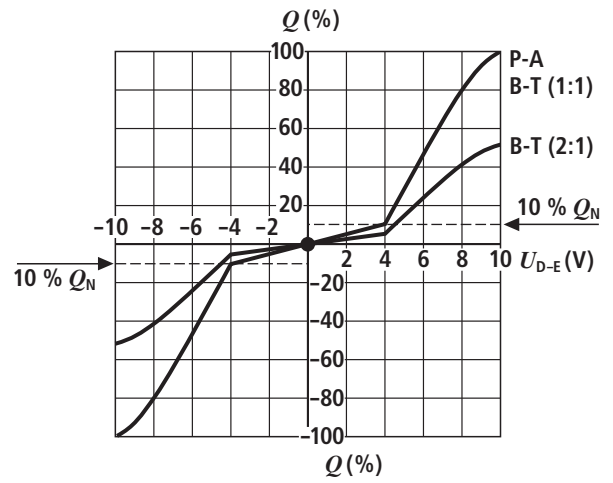

Flow characteristics L

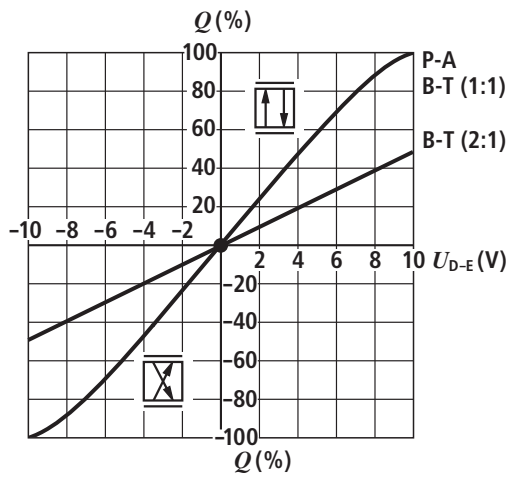

Characteristic curves (measured with HLP 46, $\vartheta_{Oil} = 40\text{ }^{\circ}\text{C} \pm 5\text{ }^{\circ}\text{C}$)

Pressure gain $\Delta = f(U_E)$

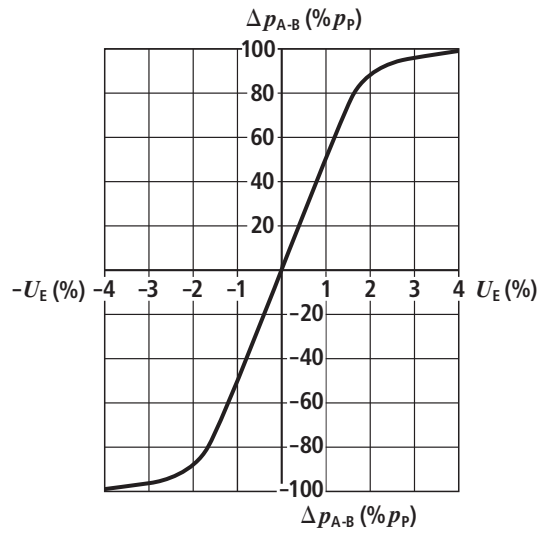
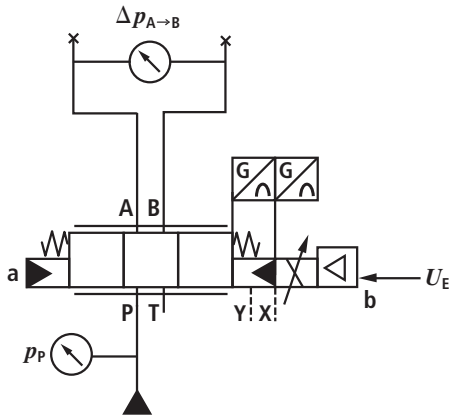

Step function 0 → 100%

Size 10

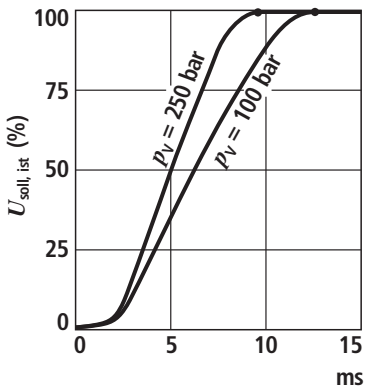

Size 16

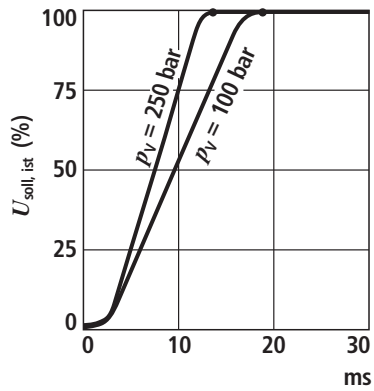

Size 25/27

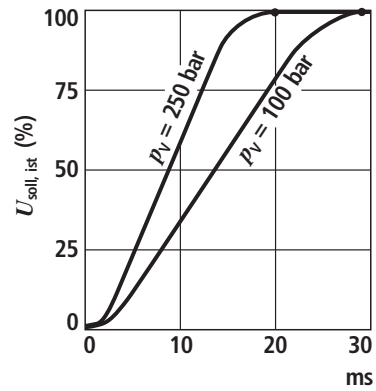

Characteristic curves (measured with HLP 46, $\vartheta_{Oil} = 40 \text{ }^\circ\text{C} \pm 5 \text{ }^\circ\text{C}$)

Bode diagram

Size 10

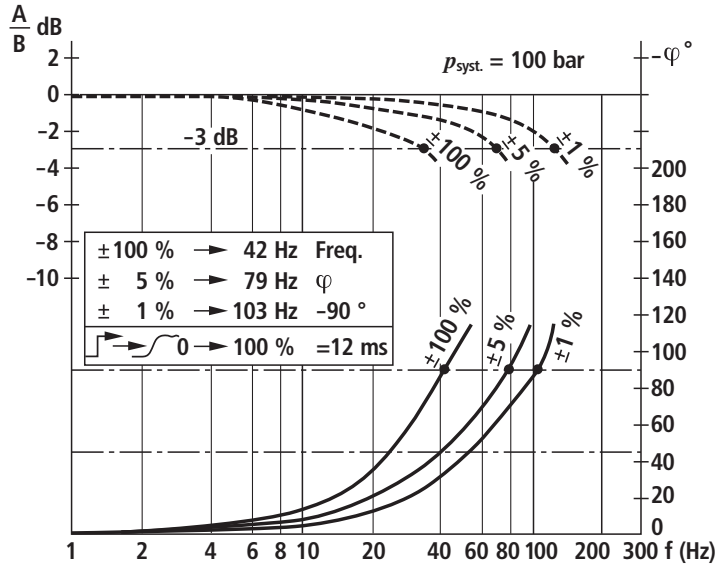

Size 16

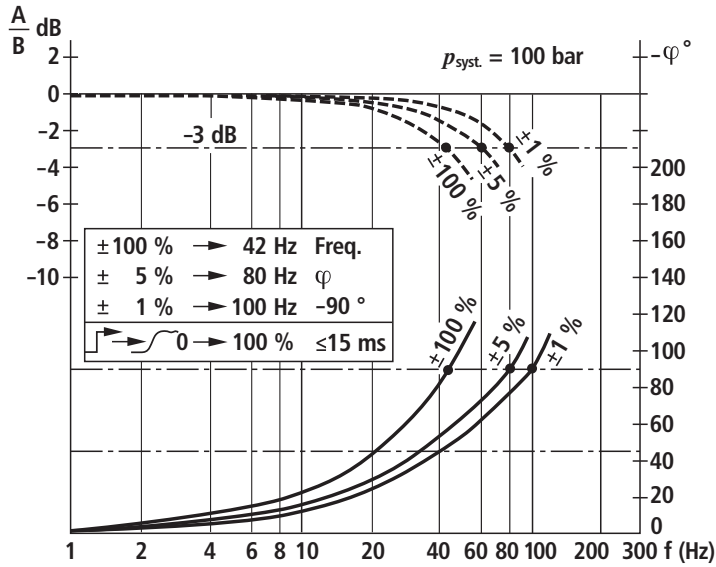

Size 25/27

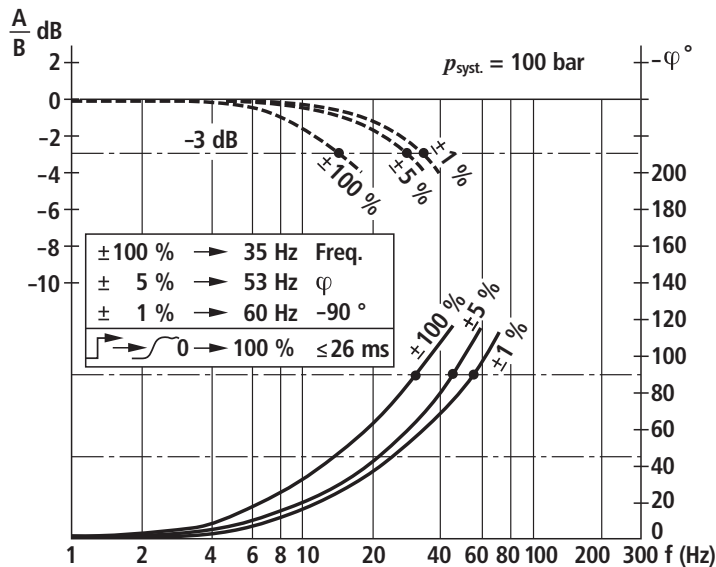

----- Amplitude
 ————— Phase

Unit dimensions size 10 (dimensions in mm)

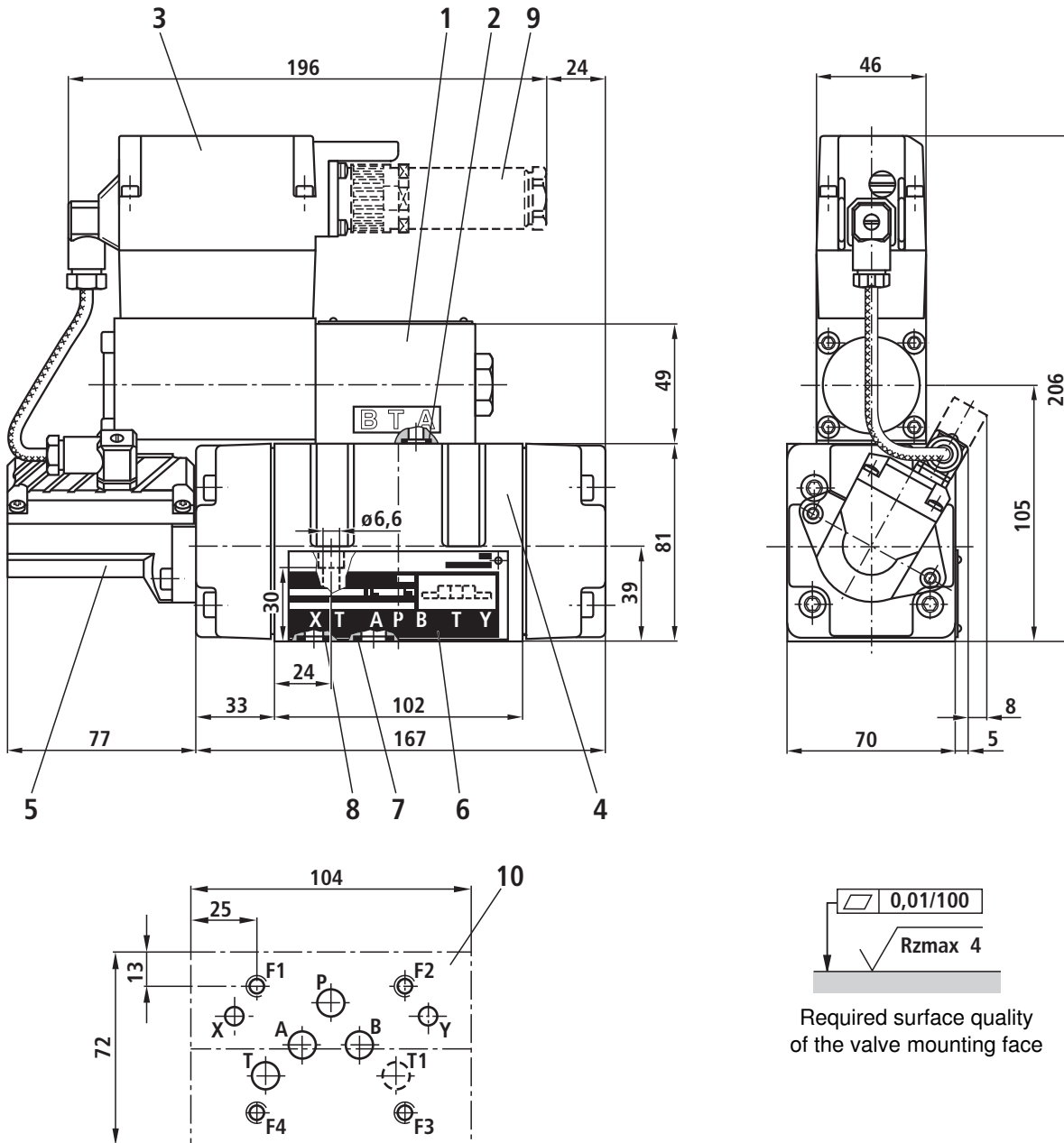

- 1 Pilot control valve
- 2 O-ring 9.25x1.78 (ports P, A, B, T)
- 3 Integrated electronics
- 4 Main valve
- 5 Inductive position transducer (main valve)
- 6 Name plate
- 7 O-ring 12x2 (ports P, A, B, T, T1)
- 8 O-ring 10x2 (ports X, Y)
- 9 Mating connector not included in the scope of delivery, see technical data sheet RE 08008 (separate order)

- 10 Machined valve mounting face, porting pattern according to ISO 4401-05-05-0-05
Deviating from the standard:
ports P, A, B, T, T1 \varnothing 10.5 mm
- Subplates**, see technical data sheet RE 45055 (separate order)
- Valve mounting screws** (separate order)
The following valve mounting screws are recommended:
- 4 hexagon socket head cap screws**
ISO 4762-M6x40-10.9-N67F821 70
(galvanized according to Bosch standard N67F821 70)
tightening torque $M_A = 11+3$ Nm
Mat. no. 2910151209

Unit dimensions size 16 (dimensions in mm)

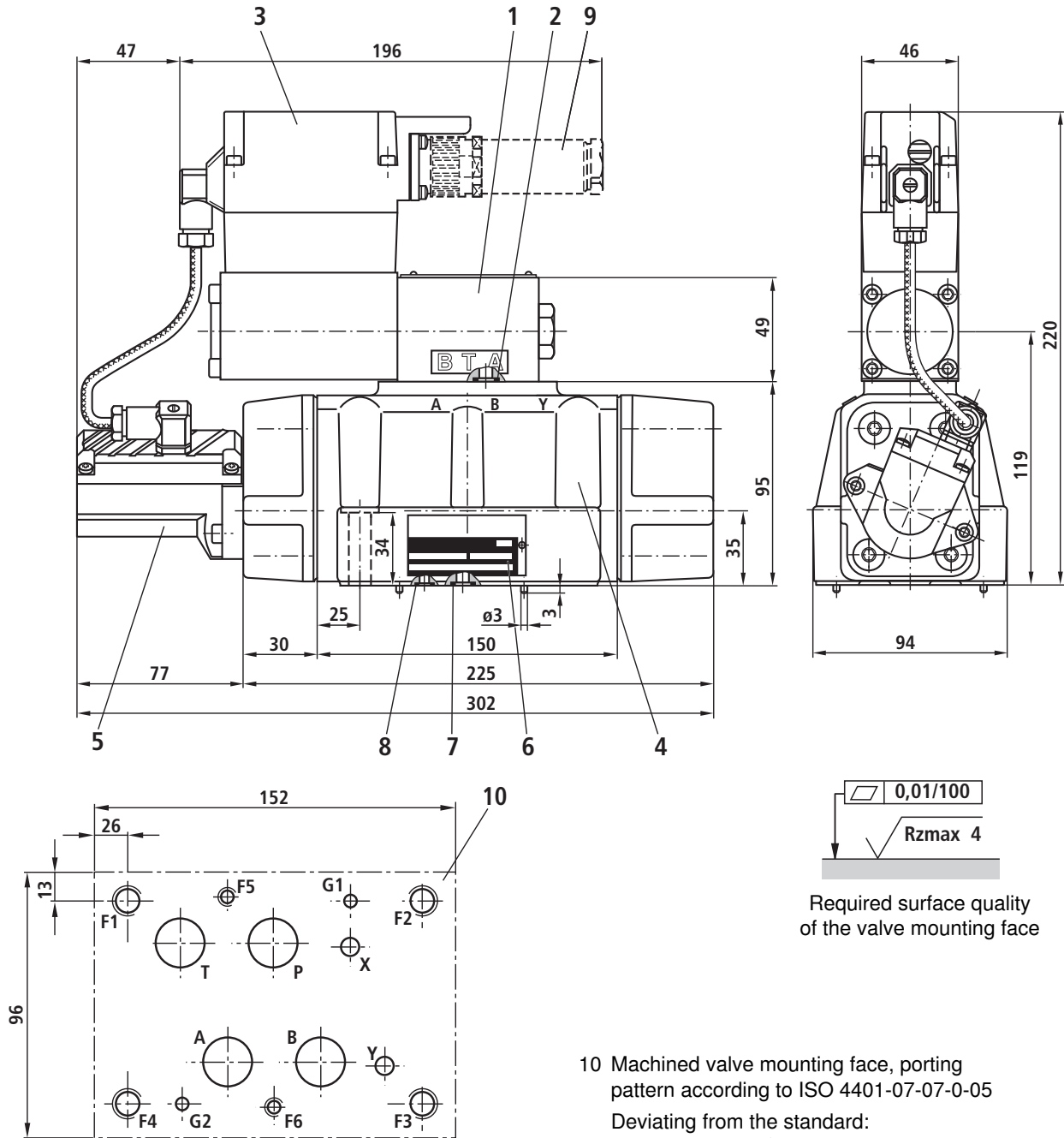

0,01/100
Rzmax 4

Required surface quality
of the valve mounting face

- 1 Pilot control valve
- 2 O-ring 9.25x1.78 (ports P, A, B, T)
- 3 Integrated electronics
- 4 Main valve
- 5 Inductive position transducer (main valve)
- 6 Name plate
- 7 O-ring 23x2.5 (ports P, A, B, T)
- 8 O-ring 9x2 (ports X, Y)
- 9 Mating connector not included in the scope of delivery, see technical data sheet RE 08008 (separate order)

10 Machined valve mounting face, porting pattern according to ISO 4401-07-07-0-05
Deviating from the standard:
ports P, A, B, T \varnothing 20 mm

Subplates, see technical data sheet RE 45057 (separate order)

Valve mounting screws (separate order)
The following valve mounting screws are recommended:

2 hexagon socket head cap screws
ISO 4762-M6x45-10.9-N67F821 70
(galvanized according to Bosch standard N67F821 70)
tightening torque $M_A = 11+3$ Nm
Mat. no. 2910151211

4 hexagon socket head cap screws
ISO 4762-M6x40-10.9-N67F821 70
(galvanized according to Bosch standard N67F821 70)
tightening torque $M_A = 50+10$ Nm
Mat. no. 2910151301

Unit dimensions size 25/27 (dimensions in mm)

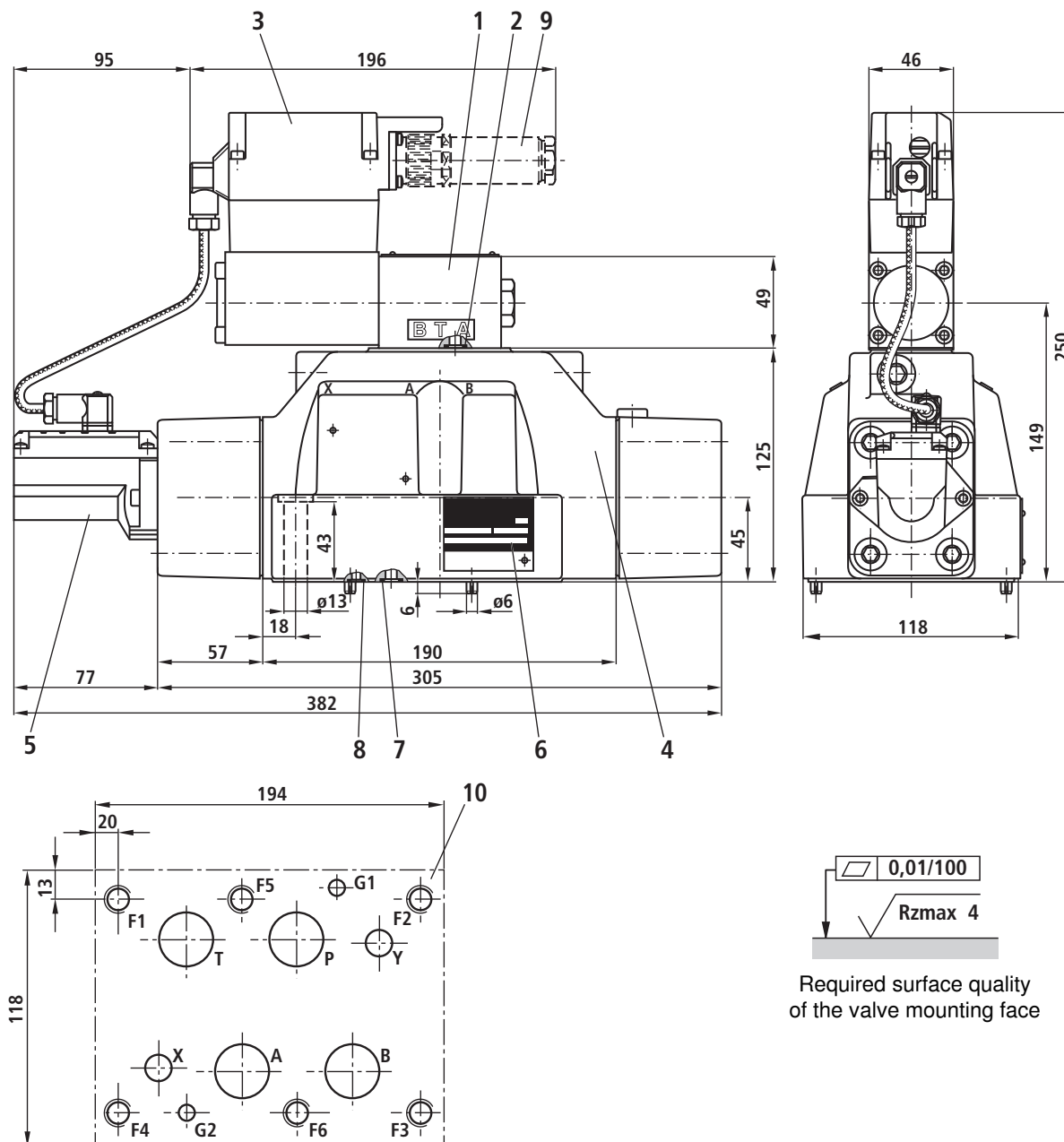

- 1 Pilot control valve
- 2 O-ring 9.25x1.78 (ports P, A, B, T)
- 3 Integrated electronics
- 4 Main valve
- 5 Inductive position transducer (main valve)
- 6 Name plate
- 7 O-ring (ports P, A, B, T)
Size 25: 28x3
Size 27: 34.6x2.62
- 8 O-ring 15x2.5 (ports X, Y)
- 9 Mating connector not included in the scope of delivery, see technical data sheet RE 08008 (separate order)

- 10 Machined valve mounting face, porting pattern according to ISO 4401-08-08-0-05
Deviating from the standard:
size 25: Ports P, A, B, T \varnothing 25 mm
size 27: Ports P, A, B, T \varnothing 32 mm

Subplates, see technical data sheet RE 45059 (separate order)

Valve mounting screws (separate order)

The following valve mounting screws are recommended:

**6 hexagon socket head cap screws
ISO 4762-M12x60-10.9-N67F821 70**

(galvanized according to Bosch standard N67F821 70)

tightening torque size 25 $M_A = 90+30$ Nm,

size 27 $M_A = 90\pm 15$ Nm

Mat. no. 2910151354

Notes

Notes
