

# 3 PIECES BALL VALVE

## Ref. 734/735/736/743/745/746

Ref. : DS 736

Rev. : 6

Date : 12/07

Page 1/2



Valves and fittings

90 rue du ruisseau 38297 ST QUENTIN FALLAVIER  
 Tel:(33)04.74.94.15.90 Fax:(33)04.74.95.62.08  
 E.mail : sferaco@sferaco.fr

**SPECIFICATIONS :**

- . Full bore
- . Anti-blow out stem
- . ISO direct mounting pad
- . Special gland pack with "Belleville" washer
- . Locking device / Red handle

**USE :**

- . For all common fluids
- . Max. temperature Ts : 180°C see graph
- . Max. pressure Ps : 63 bars see graph

**RANGE :**

- . Female/Female carbon steel **Ref. 736** 1/4" to 4"
- . But welding carbon steel **Ref. 734** DN8 to DN100
- . Socket welding carbon steel **Ref. 735** DN8 to DN100
- . Female/Female stainless steel **Ref. 746** 1/4" to 4"
- . But welding stainless steel **Ref. 745** DN8 to DN100
- . Socket welding stainless steel **Ref. 743** DN8 to DN100



**MATERIALS :**

DESIGNATION	MATERIALS 734/735/736	MATERIALS 743/745/746
Body	A 216 WCB	A 351 CF8M
End	A 216 WCB	A 351 CF8M
Ball	Stainless steel 316	Stainless steel 316
Stem	Stainless steel 316	Stainless steel 316
Seat	PTFE 15% glass	PTFE 15% glass
Packing	PTFE 15% glass	PTFE 15% glass
Gasket	PTFE 15% glass	PTFE 15% glass
Washer "Belleville"	Steel	Steel
Nut	Stainless steel 304	Stainless steel 304
Handle	Stainless steel 304	Stainless steel 304

**GRAPH Pressure / Temperature :**

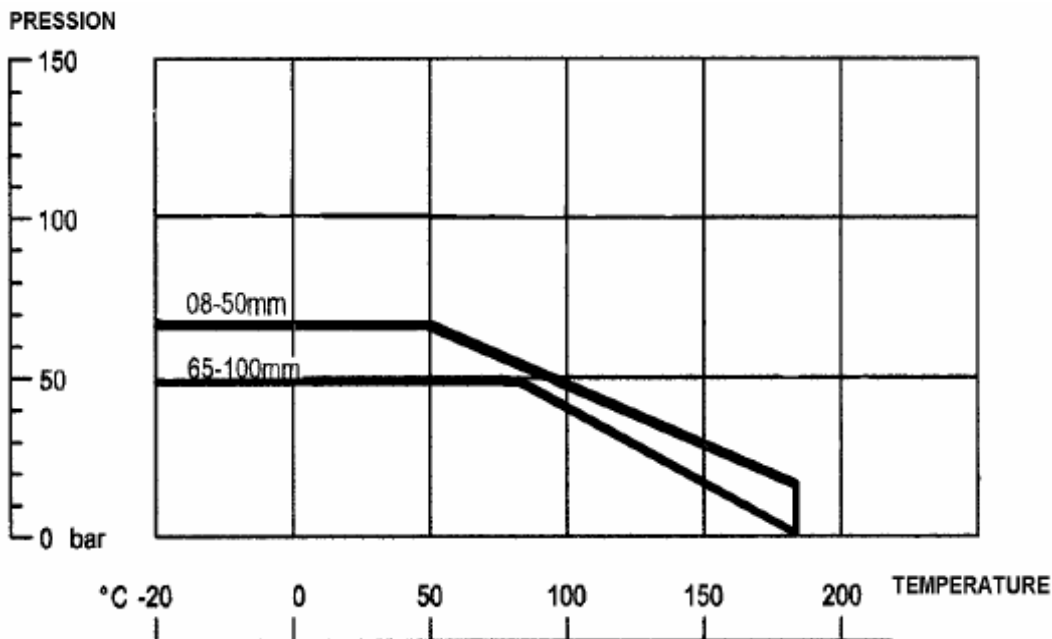

**STANDARDS :**

. DIRECTIVE 97/23/CE : CE N° 0035  
 Risk category II

# 3 PIECES BALL VALVE

## Ref. 734/735/736/743/745/746

Ref. : DS 736

Rev. : 6

Date : 12/07

Page 2/2



Valves and fittings

90 rue du ruisseau 38297 ST QUENTIN FALLAVIER  
Tel:(33)04.74.94.15.90 Fax:(33)04.74.95.62.08  
E.mail : sferaco@sferaco.fr

**SIZE :**

	DN	1/4"	3/8"	1/2"	3/4"	1"	1" 1/4"	1" 1/2"	2"	2" 1/2"	3"	4"
Ref.	L	63,5	63,5	63,5	72,5	81	94,5	108	121,5	157,5	190	225
736	H	73	73	73	80,8	90,5	98,7	115,3	124	155	208,5	216,7
746	A	37	37	37	45	53,5	59	74,8	83,5	108,8	118,3	153,8
	L1	22,5	22,5	22,5	27,5	34	42,5	52	63,5	85,5	102	129
	B	8,5	8,5	8,5	8,5	11,4	11,4	14	13,7	18	18	23
	C	9	9	9	9	9	9	14	14	17	17	17
	D	11,5	12,5	15,8	20,9	26,6	35,1	40,9	52,5	65	77,9	100
	D1	14,2	17,5	21,8	27,4	34,1	42,7	49	61	77	90,2	115,3
	E	112	112	112	112	136	185	197,9	197,9	264	264	325
	G(BW)	13,7	17,1	21,3	26,7	33,4	42,2	48,3	60,3	73	88,9	114,3
	G(SW)	28	28	28	34	41	50	57	69	88	102	126
	K	50	50	50	50	50	50	70	70	102	102	102
	ISO	F05	F05	F05	F05	F05	F05	F07	F07	F10	F10	F10
	K1	36	36	36	36	36	36	50	50	70	70	70
	ISO	F03	F03	F03	F03	F03	F03	F05	F05	F07	F07	F07
	P	10	10	10	13	13	13	13	16	16	16	22
	Weig.	0,59	0,58	0,57	0,71	1,03	1,56	2,5	3,44	6,4	10,98	22

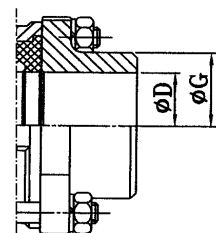

B.W. END

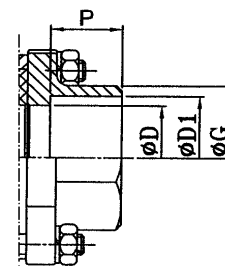

S.W. END

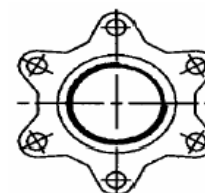
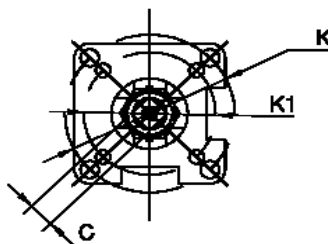
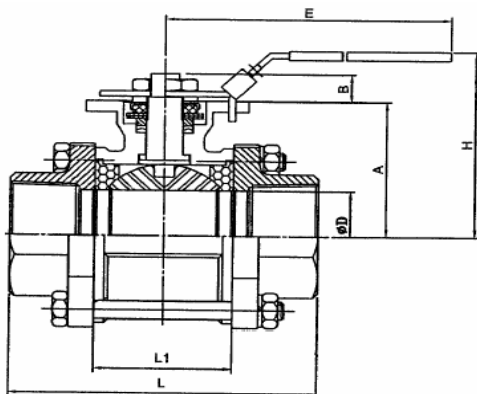

2" 1/2 to 4"

**BALL VALVE INSTALLATION :**

Before installation it is necessary :

- . To verify that the rating marked on the body valve is higher than the working pressure.
- . To be sure that the pipe-line is free from residual of weldings, rubbish, shaving and every kind of extraneous materials.
- . To check for the absence of extraneous particles in the passage, on seat and ball surface.
- . To operate the ball valve twice (open and close).

For split valves (3 pieces) with welding ends, set the valve on piping, make 3 welding point to fix the ends of the valve, unscrew and remove tie-rods and then slip off the central body of the valve. Finally complete the welding and reassemble the body valve.

**BALL VALVE MAINTENANCE**

Considering working conditions, after a certain period of work and operations the ball valves may have problems of tightness due to seats and seals settlement. Small leakage from the stem can be solved adjusting stem bolt. We suggest this operation once a year.

With reference to pictures of ball valves proceed as follows :

Unscrew and remove the first nut up to allow a slight vertical movement of the lever, without removing it from its site. Then tighten with an hexagonal key the under-placed nut keeping the lever locked by the hand. Screw the top nut to take the ball valve back to initial position. If the leakage persist we suggest servicing the valve dismounting it from the pipe-line replacing seats and seals.

**WARNING :** To order spare parts is always necessary to know the model of the valve, the ND, material and possible serial number.

To avoid damages to people or things before the service, the ball valve must be depressurised. Then follow these indications :

- Turn the lever to 45° so the ball is opened (or closed) at 50%
- Clear-up the pipe-line on which the ball valve is mounted
- Take the necessary precautions to avoid possible accident. During operations of disassembly wear always appropriate clothes and shoes, anti -acid rubber gloves, glasses, powder/gas-mask evaluating the degree of danger of the medium.

Wash accurately the ball valve.

- Turn the lever up to close the ball.
- Dismantling the ball valve unscrewing nuts from stud-bolts then remove the central body from ends.
- Remove the ball, replacing if the external surface results damaged.
- Unscrew and remove the first nut on the stem, the wrench, the second nut, spring washers and the pressing bush.
- Remove the stem with the "V" seal and the stem seal.
- Replace seats and the seals from the body.
- Replace the stem, if damaged with the bush.
- Keeping the stem in closed position, put the ball into the body, then fix the ends to the body with stud bolts.
- Reassemble the "V" seal on the stem, replacing if it damaged.
- Reassemble the pressing bush, spring washers, the nut, the lever and the top nut. Reassemble the body between ends.
- Open and close 3/4 times in order to check that the rotation is free from defects, (appropriate torque and uniformity of the ball rotation).

**ADVICE :** Our opinion and our advice are not guaranteed and SFERACO shall not be liable for the consequences of damages. The customer must check the right choice of the products with the real service conditions.