

# Drive System Rexroth IndraDrive

Complete, intelligent and safe







Discover the unlimited possibilities of Rexroth's automation systems. They integrate all control and drive components to provide optimum automation solutions: state-of-the-art, ultra-efficient, and highly future-proof.

<b>Contents</b>	
<b>Drive expertise</b>	<b>04</b>
<b>System overview</b>	<b>08</b>
<b>Selection guide</b>	<b>10</b>
<b>Power units IndraDrive C and M</b>	<b>12</b>
<b>Control units IndraDrive C and M</b>	<b>36</b>
<b>Multi-protocol-capable compact drive system IndraDrive Cs</b>	<b>50</b>
<b>Cabinet-free drive technology IndraDrive Mi</b>	<b>54</b>
<b>Firmware</b>	<b>62</b>
<b>Motion logic</b>	<b>64</b>
<b>Safety technology</b>	<b>66</b>
<b>Engineering and operation</b>	<b>70</b>
<b>Motors and gearboxes</b>	<b>74</b>
<b>Auxiliary components</b>	<b>112</b>
<b>Glossary</b>	<b>136</b>
<b>Formulas</b>	<b>138</b>
<b>Additional information</b>	<b>140</b>

# Rexroth IndraDrive and Rexroth IndraDyn cause a stir in the drive market

Solve your automation challenges easily, cost-efficiently and safely with systems from Rexroth.

IndraDrive sets new standards in drive technology with a combination of three product advantages:

- ▶ Scalable in power and functionality
- ▶ Consistent in technology, engineering and operation
- ▶ Open in communication

This means that IndraDrive has numerous application advantages to offer, e.g.:

- ▶ Easy realization of frequency converter to high-end servo applications by using a common platform for open and closed loop
- ▶ Scalable range of performance and functionality thanks to the free combination of control and power components
- ▶ Wide performance range from 100 W to 630 kW
- ▶ Internationally standardized interfaces from analog input to Multi-Ethernet interface
- ▶ Integrated safety technology compliant with EN 13849-1 Cat. 3 PL d and EN 62061 SIL 2 for Safe Stop and Safe Motion
- ▶ Intelligent motion logic with PLC according to IEC 61131-3
- ▶ Uniform operating philosophy
- ▶ Consistent engineering tool
- ▶ Direct power connection
- ▶ Common DC bus for exchanging energy in multiple-axis mode
- ▶ Energy-saving power recovery
- ▶ Motors with the highest level of efficiency



## IndraDrive has the power to convince

No matter what demands you make on your drive – IndraDrive offers an impressive array of key benefits:

- ▶ Integrated hardware platform
- ▶ Scalable functionality
- ▶ Unique safety concept



### Safety on Board

Safety technology certified to EN 13849-1 Cat. 3 PL d and EN 62061 SIL 2, protects machine operators while the drives are in motion. In contrast to conventional safety designs, there is no longer any need for motor contactors, additional speed monitors or frequent power shutdown using the line contactor.

### Integrated motion logic with IEC 61131-3 compliant PLC

Motion logic with IEC 61131-3 compliant PLC can be integrated as an optional feature that consistently applies open standards.

This makes it easier to bring in customer know-how and saves on higher-level control systems and personnel training courses.

### Integrated technology functions

The technology functions can be configured on the basis of motion logic to perform a wide and diverse range of process-oriented tasks. This does not require any programming knowledge whatsoever on the user's part.

### Open interfaces

Internationally recognized interfaces are available for communicating with higher-level machine control systems: sercos, PROFIBUS, Multi-Ethernet (sercos, PROFINET IO, EtherNet/IP, EtherCAT), CANopen, DeviceNet, analog and parallel.

### A single software for all tasks

The engineering framework, IndraWorks, carries you through all the steps involved in project planning, programming, parameterization, operation and diagnostics.

### A unique platform

In the interests of meeting your individual requirements, we have developed two versions of IndraDrive:

- ▶ IndraDrive C – compact converters
- ▶ IndraDrive M – modular inverters

Particularly economic drive solutions can be derived from the common control units and the combination of different versions.

### A complete range of motors

The newly developed generation of IndraDyn motors meets all the requirements of modern factory automation through its diversity of design and unique performance:

- ▶ Synchronous and asynchronous servo motors which are more compact and more powerful
- ▶ Servo motors designed for potentially explosive areas – conforming to ATEX and UL/CSA
- ▶ Synchronous and asynchronous motors for high-speed applications such as motor spindles

- ▶ Automation
- ▶ Printing and converting machines
- ▶ Conveying and storage systems
- ▶ Glass processing machines
- ▶ Handling and assembly systems
- ▶ Woodworking machines
- ▶ Plastics processing machines
- ▶ Semiconductor technology
- ▶ Food processing and packaging machines
- ▶ Textile machines
- ▶ Metal forming
- ▶ Machine tools

# Rexroth IndraDrive – complete, intelligent and safe

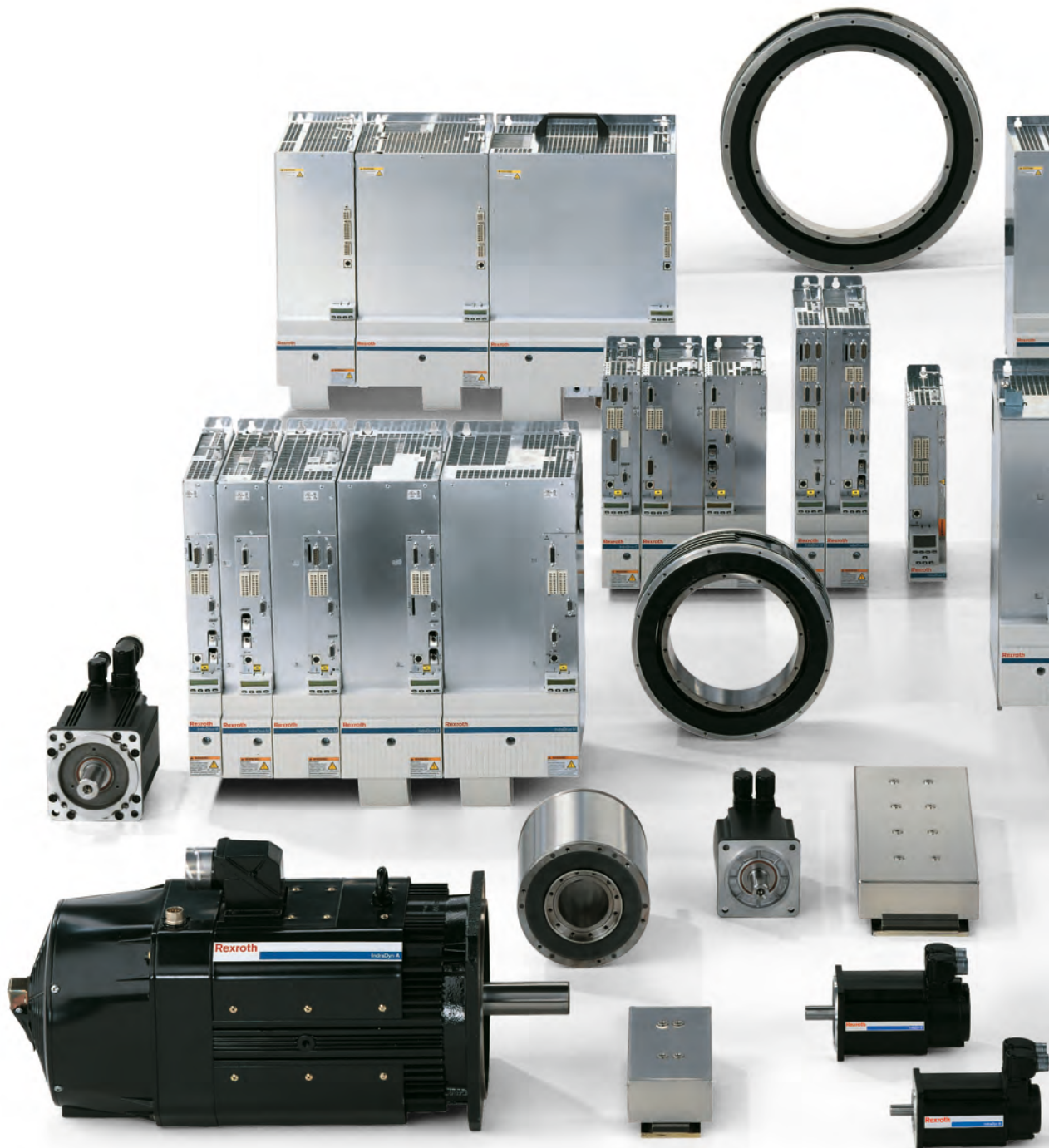















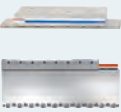

IndraDrive stands for innovation all along the line. Therefore, choosing the new drive generation from Rexroth means that your every wish will be fulfilled.

Main features of the IndraDrive:

- ▶ Compact converters and modular inverters on one platform
- ▶ Ethernet-based communications hardware with multi-protocol support
- ▶ Ultra-compact drive unit consisting of control unit and servo motor
- ▶ Integrated motion logic with IEC-compliant PLC
- ▶ Drive-integrated safety technology
- ▶ Intelligent technology functions
- ▶ Integrated engineering framework for project planning, programming, operation and diagnostics
- ▶ Complete range of synchronous and asynchronous motors



# Rexroth IndraDrive – the complete system

Motors and gearboxes	Power units	Control units
 <p><b>Synchronous servo motors</b>                      IndraDyn S, MSK, MKE, MSM                      Page 76 – 85</p>	 <p><b>Compact drives featuring Ethernet-based communications</b>                      HCS01 converter – ECONOMY and BASIC UNIVERSAL versions                      Pages 50 – 53</p>	
 <p><b>Asynchronous servo motors</b>                      IndraDyn A, MAD, MAF                      Pages 86 – 93</p>	<p><b>Converters</b>                      HCS02                      Pages 16/17</p> <p>HCS03                      Pages 18/19</p> <p>HCS04                      Pages 20/23</p>  	<p><b>Complete solutions for standard applications</b></p> <p><b>BASIC OPEN LOOP</b>                      CSB...FC                      Page 40</p> <p><b>BASIC ANALOG</b>                      CSB...AN                      Page 41</p> <p><b>BASIC PROFIBUS</b>                      CSB...PB                      Page 42</p> <p><b>BASIC SERCOS</b>                      CSB...SE                      Page 43</p>
 <p><b>Synchronous linear motors</b>                      IndraDyn L, MLF, MCL                      Pages 94 – 97</p>	<p>Converters and inverters can be combined</p> 	<p><b>Individually configurable for standard and high-end applications</b></p>
 <p><b>Synchronous torque motors</b>                      IndraDyn T, MBT                      Pages 98/99</p>	<p><b>Inverters</b>                      HMS (single-axis unit)                      Pages 24 – 27</p> <p>HMD                      (double-axis unit)                      Pages 28/29</p>  	<p><b>BASIC UNIVERSAL</b>                      CSB (single-axis control unit)                      Page 44</p>
 <p><b>Synchronous high-speed motors</b>                      IndraDyn H, MBS                      Pages 100/101</p>	<p>Power supplies and inverters can be combined</p> 	<p><b>BASIC UNIVERSAL</b>                      CDB (double-axis control unit)                      Page 45</p>
 <p><b>Asynchronous high-speed motors</b>                      1MB                      Pages 102/103</p>	<p><b>Power supply units</b>                      HMV                      Pages 30 – 33</p>  	<p><b>ADVANCED</b>                      CSH                      Page 46</p>
 <p><b>Gearboxes for servo motors</b>                      GTE, GTM                      Pages 104 – 107</p>	<p><b>Cabinet-free drive technology</b>                      KSM, KMS, KCU, Pages 54 – 61</p> 	















For converters and inverters



## Seamlessly coordinated













- ▶ Integrated system
- ▶ Scalable power
- ▶ Flexible function blocks
- ▶ Open communication standards
- ▶ Future-proof



Firmware	Engineering & operation	Auxiliary components
<p><b>Basic package</b></p> <div data-bbox="108 691 474 776" style="border: 1px solid black; padding: 5px; margin-bottom: 5px;"> <p><b>OPEN LOOP/ CLOSED LOOP</b></p> </div> <p>The basic package contains all the functions for standard applications.</p>	<p><b>Operator panels</b> VCP, VCH, VEP Page 47</p> 	<p><b>Mains filters</b> HNF, HNS, NFD Page 114</p> 
<p><b>Extension packages</b></p> <div data-bbox="108 932 474 1017" style="border: 1px solid black; padding: 5px; margin-bottom: 5px;"> <p><b>SERVO</b></p> </div> <p>Frictional torque compensation and compensation for backlash on reversal, axis and encoder error correction, probe, etc.</p>	<p><b>Software module</b> PFM Page 47</p> 	<p><b>Mains filters, mains choke</b> HNK Page 115</p> 
<div data-bbox="108 1144 474 1229" style="border: 1px solid black; padding: 5px; margin-bottom: 5px;"> <p><b>SYNCHRONIZATION</b></p> </div> <p>Electronic gears, electronic cam plate, etc.</p>	<p><b>IndraWorks</b> Engineering software framework for start-up, programming, etc. Pages 70/71</p> 	<p><b>Mains chokes</b> HNL Pages 116/117</p> <p><b>DC chokes</b> HLL Page 118</p> 
<div data-bbox="108 1325 474 1410" style="border: 1px solid black; padding: 5px; margin-bottom: 5px;"> <p><b>MAIN SPINDLE</b></p> </div> <p>Spindle positioning, gear change, etc.</p>	<p><b>Cables and connectors</b></p>	<p><b>Motor filters</b> HMF Page 119</p> 
<div data-bbox="108 1517 474 1602" style="border: 1px solid black; padding: 5px; margin-bottom: 5px;"> <p><b>IndraMotion MLD</b></p> </div> <p>Motion logic conforming to IEC 61131-3</p>	<p><b>Power cables</b> RKL Pages 134/135</p> 	<p><b>Brake resistors</b> HLR Pages 121 – 123</p> 
<div data-bbox="108 1687 474 1772" style="border: 1px solid black; padding: 5px; margin-bottom: 5px;"> <p><b>Technology packages based on IndraMotion MLD</b></p> </div> <p>Productivity Agent (predictive maintenance), function blocks, demand processing, special programmable limit switches, extended drive function, PLCopen library, etc.</p>	<p><b>Encoder cables</b> RKG Pages 135</p> 	<p><b>Brake chopper</b> HLT Page 120</p> <p><b>Brake units</b> HLB Page 124</p> 
<p>Pages 62/63</p>	<p><b>Fiber optic cables, bus connectors, etc.</b></p> 	<p><b>Capacity modules</b> HLC Page 125</p> 
	<p><b>Hybrid cable, terminal connector</b> RKH Page 61</p> 	<p><b>Blower unit</b> HAB Page 126</p> 

# Five steps to your drive solution



Step	Example	Help
<b>1 Determine your drive requirements</b> <ul style="list-style-type: none"> <li>▶ Torque, speed, power...</li> <li>▶ Performance (control quality...)</li> <li>▶ Interfaces, functions</li> <li>▶ Single-axis or multi-axis drive</li> </ul> 	<b>Servo drive for a handling axis</b> <ul style="list-style-type: none"> <li>▶ RMS torque 4.5 Nm</li> <li>▶ Maximum torque 8 Nm</li> <li>▶ Speed 2,500 rpm</li> <li>▶ PROFIBUS interface</li> <li>▶ Simple servo functionality</li> </ul> 	<b>Drive sizing program</b> IndraSize Pages 72/73  
<b>2 Select the power unit/motor combination</b> 	<b>IndraDrive C with IndraDyn S</b> <b>HCS02.1E-W0028-A-03-NNNN</b> <b>MSK050C-0300-NN-S1-UG0-NNNN</b> <ul style="list-style-type: none"> <li>▶ Standstill torque 5 Nm</li> <li>▶ Maximum torque 15 Nm</li> <li>▶ Maximum speed 4,700 rpm</li> </ul> 	<b>Power units</b> Pages 12 – 35  <b>Motors</b> Pages 74 – 111  
<b>3 Identify the control unit performance and interfaces</b> <ul style="list-style-type: none"> <li>▶ Higher-level control system</li> <li>▶ Encoder</li> <li>▶ Inputs and outputs</li> <li>▶ Safety technology</li> </ul> 	<b>Control unit BASIC PROFIBUS</b> <b>CSB01.1N-PB-ENS-NNN-NN-S-NN-FW</b> <ul style="list-style-type: none"> <li>▶ Standard performance</li> <li>▶ PROFIBUS</li> <li>▶ IndraDyn standard encoder</li> <li>▶ Standard operator panel</li> <li>▶ No additional options</li> </ul> 	<b>Control units</b> Pages 36 – 49  
<b>4 Define the firmware function</b> <ul style="list-style-type: none"> <li>▶ Basic OPEN LOOP or CLOSED LOOP package</li> <li>▶ Extension packages</li> <li>▶ Motion logic</li> <li>▶ Technology functions</li> </ul> 	<b>Basic CLOSED LOOP package</b> FWA-INDRV*-MPB-xxVRS-D5-1-NNN-NN <ul style="list-style-type: none"> <li>▶ No extension packages</li> </ul> 	<b>Firmware</b> Pages 62/63  
<b>5 Select the accessories</b> <ul style="list-style-type: none"> <li>▶ Mains filters and mains chokes</li> <li>▶ Brake resistors, brake units</li> <li>▶ Capacity modules</li> <li>▶ Cables and connectors</li> <li>▶ Software</li> </ul>	<b>Mains filter</b> NFD03.1-480-016 <b>Power cable</b> RKL4302/005.0 <b>Encoder cable</b> RKG4200/005.0 <b>Basic accessories</b> HAS01.1-065-NNN-CN <b>Shield connection</b> HAS02.1-002-NNN-NN <b>Software</b> SWA-IWORKS-D**-xxVRS-D0-DVD**-COPY	<b>Auxiliary components</b> Pages 112 – 135  <b>Engineering framework</b> IndraWorks Pages 70/71

# Rexroth IndraDrive – power units



## Customized for the desired number of axes and power level

- ▶ Wide power range – for all applications
- ▶ Converters and inverters can be combined – ideal for small axis groups
- ▶ Power supplies and inverters can be combined – ideal for large axis groups



## IndraDrive C – compact converters

- ▶ Power range from 1.5 kW to 630 kW with maximum current from 12 A to 1,535 A
- ▶ High overload capacity
- ▶ Compact design for single-axis applications
- ▶ Can be connected to inverters for cost-effective solutions
- ▶ Direct mains connection from 200 V to 500 V



Converters and inverters can be combined

## IndraDrive M – modular inverters

- ▶ Single-axis inverter with maximum current from 20 A to 350 A
- ▶ Double-axis inverter with maximum current from 12 A to 36 A
- ▶ Space-saving design for multi-axis applications
- ▶ Can be powered via power supply unit or converter
- ▶ Energy exchange via common DC bus
- ▶ Can be connected to a converter for cost-effective solutions



Power supplies and inverters can be combined

## IndraDrive M – modular power supplies

- ▶ Power range from 15 kW to 120 kW
- ▶ Direct mains connection from 400 V to 480 V
- ▶ Energy-saving line regeneration
- ▶ Integrated mains contactor
- ▶ Integrated brake resistor



# IndraDrive – the clever combination of power units

## Single-axis solution with a converter

The IndraDrive C series of converters integrate inverter and power supply in one unit. The compact construction contains additional mains connection components, making it particularly suitable for single-axis applications.



## Multi-axis solution with converters and inverters

A combination of IndraDrive C converters and modular IndraDrive M inverters is a particularly cost-effective solution for small axis groups.

The converter for the first axis supplies the inverters of the other axes at the same time. In this case, a converter with sufficient power reserve must be selected in order to be able to supply the smaller inverters as well.

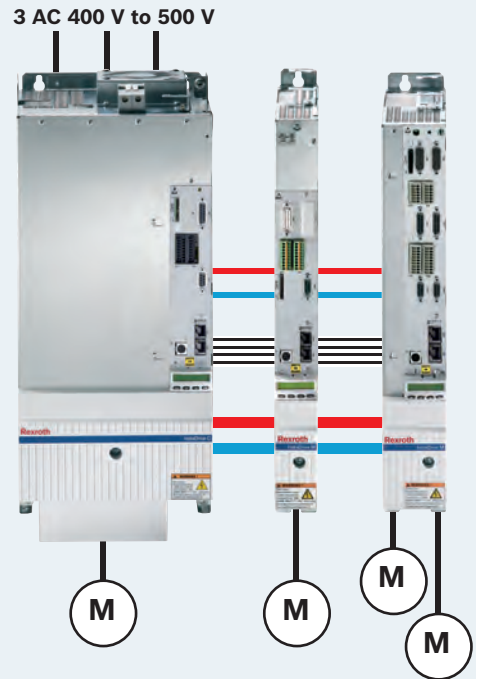

## Multi-axis solution with power supplies and inverters

Multi-axis applications are the domain of the modular system IndraDrive M. Power supplies provide the necessary DC bus voltage for the inverters. Compact single-axis or double-axis inverters and power supplies with integrated mains connection components enable compact solutions for large axis groups.

Maximum energy efficiency can be achieved with power supplies that are capable of mains regeneration. Beside the power recovery encountered in regenerative operation of the drives, these devices also feature sinusoidal line currents, an overall power factor of 0.99 and a closed-loop DC bus.

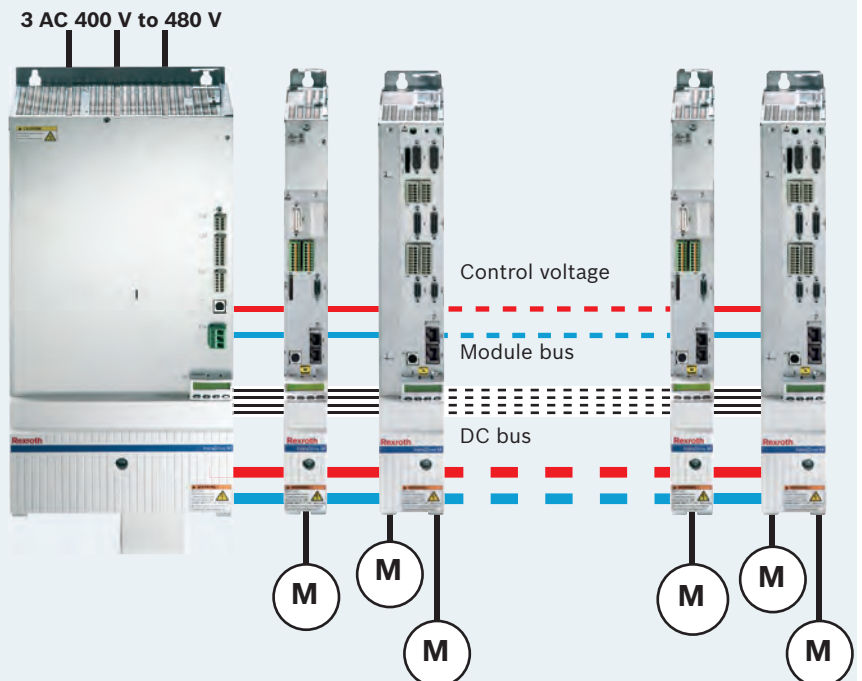

Power units		IndraDrive C			IndraDrive M			
		Converter			Inverter	Power supply units, infeed	Power supply units, regenerative	
		HCS02	HCS03	HCS04	HMS01/HMS02 HMD01	HMV01.1E	HMV01.1R HMV02.1R	
Mains voltage	V	1 AC 200 to 250 3 AC 200 to 500 (±10%)	3 AC 400 to 500 (+10%/–15%)	3 AC 380 to 480 (+10%/–15%)	–	3 AC 400 to 480 (+10%/–15%)		
Supply frequency	Hz	48 to 62			–	48 to 62		
DC bus continuous power	kW	2.1 to 14	13 to 85	–	–	18 to 120		
Continuous mechanical power <sup>1)</sup>	kW	1.5 to 11	11 to 75	110 to 630	1.5 to 132	–		
Overload capacity		2.5x	1.5 to 2x	1.2 to 1.65x	1.5 to 2.5x	1.5x	1.5 to 2.5x	
Switching frequency/ max. output frequency	kHz/Hz	4/400			4/400	–		
		8/800			8/800	–		
		12/1,200			–	12/1,200 <sup>2)</sup>	–	
		16/1,600			–	16/1,600 <sup>2)</sup>	–	
Output voltage	V	0 to 335 (at DC bus voltage DC 475 V) 0 to 400 (at DC bus voltage DC 570 V) 0 to 530 (at DC bus voltage DC 750 V)			–			
Suitable for cabinet depth	mm	300	400	600	HMx01: 400/HMx02: 300			
Mains contactor		External			–	Internal <sup>3)</sup>		
Brake chopper		Internal		Internal or external	–	Internal <sup>3)</sup>		
Brake resistor		Internal (optional: external)	External		–	Internal <sup>3)</sup>		
Converter/inverter combination		Yes	Yes	Yes	Yes	–		
Control voltage DC 24 V		External (optional: internal)	Internal or external		External			
Protection category		IP20						
Installation height	m	1,000 above sea level, with derating to 4,000 <sup>4)</sup>						
Ambient temperature	°C	0 to +40, with derating to +55						
Relative air humidity	%	5 to 95 (as per EN 61800-5-1), no dewing						
Degree of contamination		2 (as per EN 61800-5-1)						
Cooling system		Air cooling						
CE mark		Complies with the Low Voltage Directive 73/23/EEC and the EMC Directive 89/336/EEC						
Certification		EN 61800-5-1, EN 61800-3, UL 508C, C22.2 No. 14-05						
EMC		C3 (as per EN 61800-3)						

All data for nominal rating at 3 AC 400 V mains voltage and 4 kHz switching frequency

<sup>1)</sup> Applies to S1 mode on 4-pole standard motors 3 AC 400 V/50 Hz at 4 kHz switching frequency and a rotary frequency > 4 Hz

<sup>2)</sup> HMD01 and HMS02.1N-W0028 up to 8 kHz/800 Hz only

<sup>3)</sup> Not applicable for HMV01.1R-W0120

<sup>4)</sup> HCS04 up to 3,000 m

# IndraDrive C – compact converters HCS02

		Converters			
Model		HCS02.1E-W0012	HCS02.1E-W0028	HCS02.1E-W0054	HCS02.1E-W0070
- with integrated control voltage supply		-A-03-NNNV	-A-03-NNNV	-A-03-NNNV	-A-03-NNNV
- with integrated temperature-dependent fan control		-A-03-LNNN	-A-03-LNNN	-A-03-LNNN	-A-03-LNNN
- no additional options		-A-03-NNNN	-A-03-NNNN	-A-03-NNNN	-A-03-NNNN
<b>Performance data</b>					
Continuous current <sup>1)</sup>	A	4.5	11.3	20.6	28.3
Maximum current	A	11.5	28.3	54	70.8
DC bus continuous power without/with choke	kW	2.1/2.1	5.1/5.1	7/10	9/14
Maximum output without/with choke	kW	5/5	8/10	12/16	14/19
Mains voltage	V	3 AC 200 to 500, 1 AC 200 to 250 ( $\pm 10\%$ )			
Continuous input mains current	A	6	13	19	30
Dependence of output on mains voltage		at $U_{LN} < 400$ V: 1% power reduction per 4 V at $U_{LN} > 400$ V: 1% power gain per 5 V			
DC bus terminal <sup>2)</sup>		–	•	•	•
DC bus capacity	$\mu$ F	135	270	405	675
<b>Brake resistor</b>					
Brake resistor		Internal	Internal	Internal/external	Internal/external
Maximum braking energy consumption	kWs	1	5	9	13
Permanent braking power	kW	0.05	0.15	0.35/3.8	0.5/5.5
Maximum braking power	kW	4	10	18	25
<b>Control voltage data</b>					
Control voltage, internal	V	DC 24 (not for supply of motor holding brake)			
Control voltage, external	V	DC 24 $\pm 20\%$ (DC 24 $\pm 5\%$ when supplying motor holding brake)			
Power consumption without control unit and motor brake	W	12	14	23	23
Continuous current without control unit and motor brake	A	0.5	0.6	1	1
<b>Mechanical data</b>					
Width W	mm	65	65	105	105
Height H	mm	290		352	
Depth D	mm	252			
Weight	kg	2.9	3.8	6.7	6.8

All data for nominal rating at 3 AC 400 V mains voltage and 4 kHz switching frequency

<sup>1)</sup> In case of output frequency less than 4 Hz the output current will be reduced; <sup>2)</sup> For the connection of additional units, such as HMS, HCS, HLB, HLC

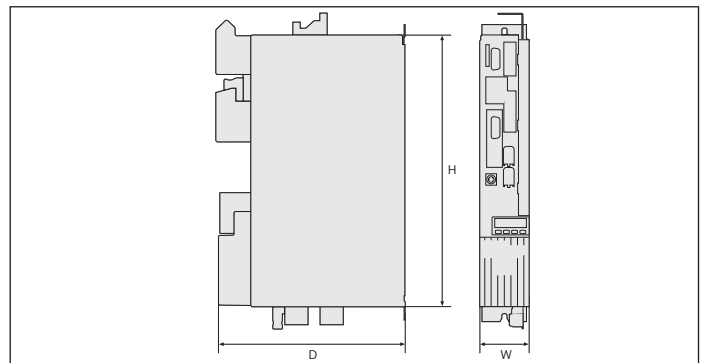



# HCS02

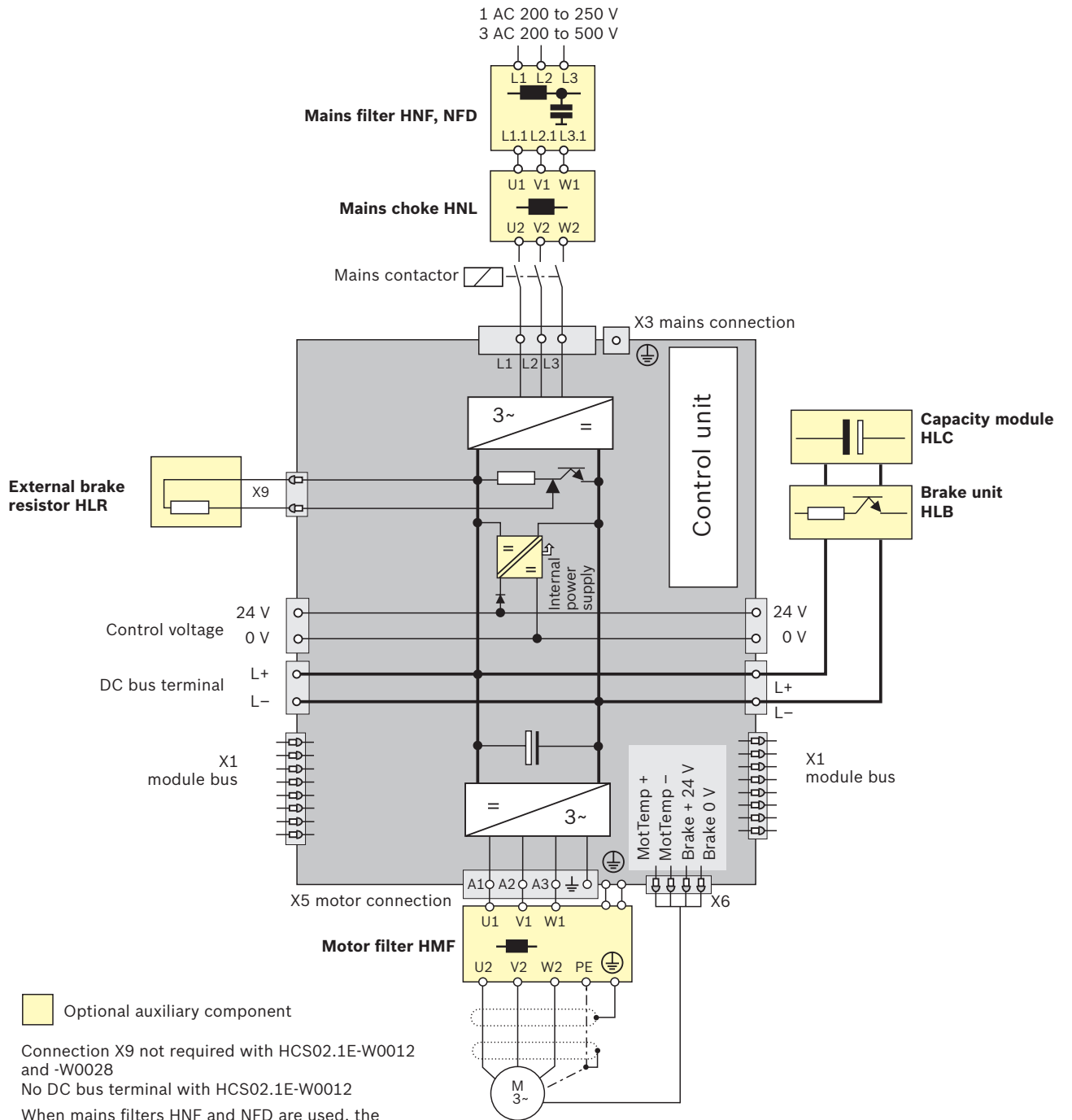

# IndraDrive C – compact converters HCS03

Model	Converter				
	HCS03.1E-W0070	HCS03.1E-W0100	HCS03.1E-W0150	HCS03.1E-W0210	
- with integrated control voltage supply	-A-05-NNNV	-A-05-NNNV	-A-05-NNNV	-A-05-NNNV	
- with integrated control voltage supply and brake chopper	-A-05-NNBV	-A-05-NNBV	-A-05-NNBV	-A-05-NNBV	
- with integrated control voltage supply, brake chopper and fan control	-A-05-LNBV	-A-05-LNBV	-A-05-LNBV	-A-05-LNBV	
<b>Performance data</b>					
Continuous current <sup>1)</sup>	A	45	73	95	145
Maximum current	A	70	100	150	210
DC bus continuous power without/with choke	kW	13/25	24/42	34/56	42/85
Maximum output without/with choke	kW	20/40	33/59	54/89	68/124
Mains voltage	V	3 AC 400 to 500 (+10%/-15%)			
Continuous input mains current	A	50	80	106	146
Dependence of output on mains voltage		at $U_{LN} < 400$ V: 1% power reduction per 4 V decrease in voltage			
DC bus terminal <sup>2)</sup>		●	●	●	●
DC bus capacity	μF	940	1,440	1,880	4,700
<b>Brake chopper</b>					
Permanent braking power	kW	13.2	18.9	25.2	42.6
Maximum braking power	kW	42	63	97	137
<b>Control voltage data</b>					
Control voltage, internal	V	DC 24 (not for supply of motor holding brake)			
Control voltage, external	V	DC 24 ±20% (DC 24 ±5% when supplying motor holding brake)			
Power consumption without control unit and motor brake	W	22.5	25	25	30
Continuous current without control unit and motor brake	A	0.9	1	1	1.3
<b>Mechanical data</b>					
Width W	mm	125	225	225	350
Height H	mm	440			
Depth D	mm	315			
Weight	kg	13	20	20	38

All data for nominal rating at 3 AC 400 V mains voltage and 4 kHz switching frequency

<sup>1)</sup> In case of output frequency < 4 Hz the output current will be reduced; <sup>2)</sup> For the connection of additional units, such as HMS, HCS, HLB, HLC

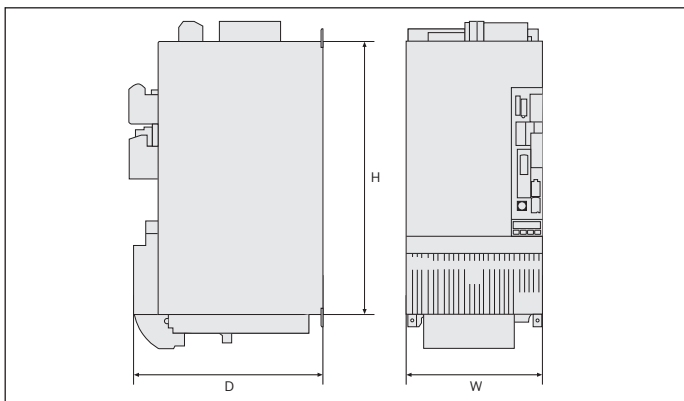

# HCS03

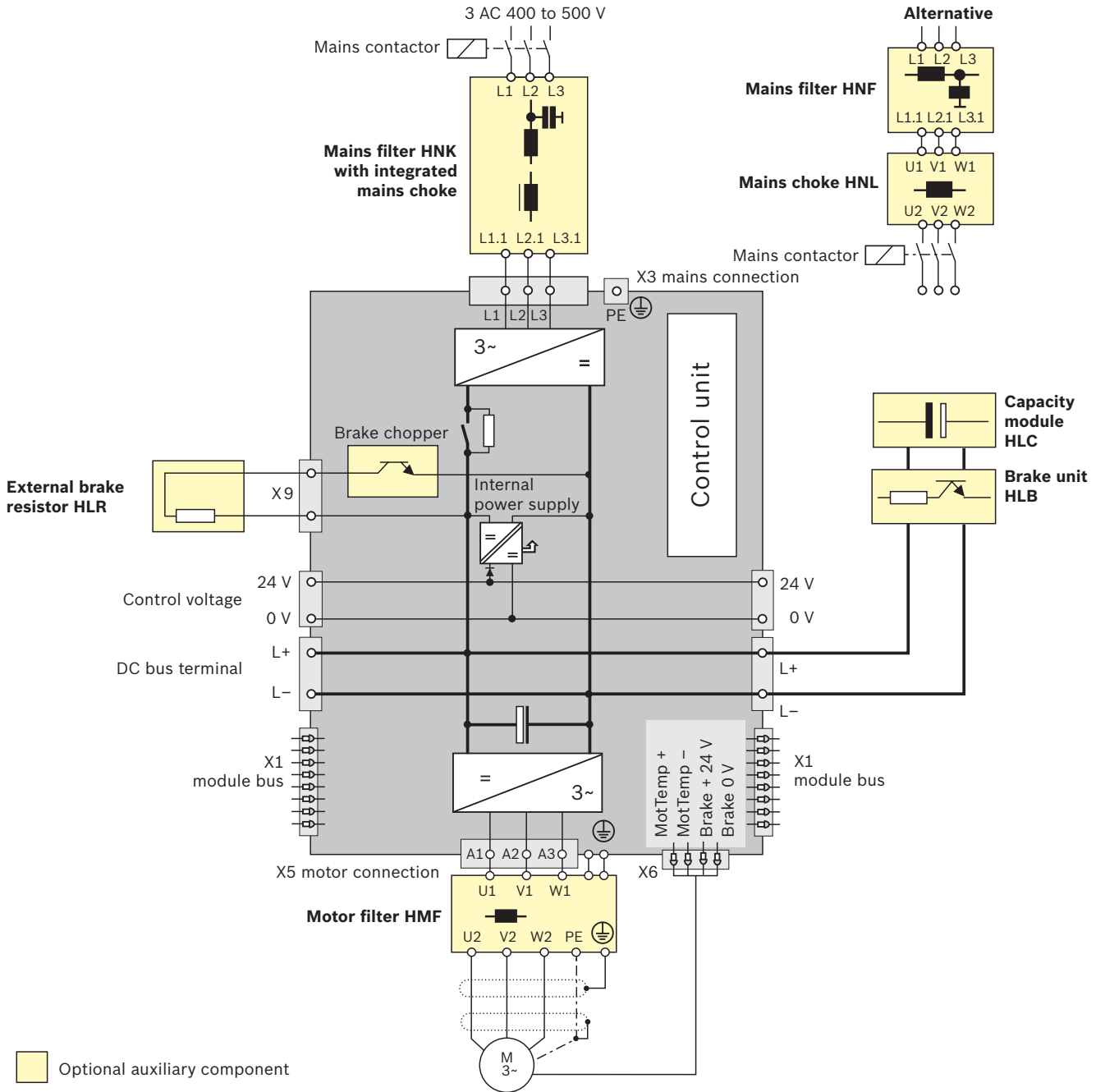

 Optional auxiliary component

Capacity module HLC on HCS03.1E-W0210 only

When mains filter HNF is used, the maximum input voltage is 3 AC 480 V.

# IndraDrive C – powerful converters HCS04

		Converter							
Model		HCS04.2E- W0350-N- 04-NNBN	HCS04.2E- W0420-N- 04-NNBN	HCS04.2E- W0520-N- 04-NNBN	HCS04.2E- W0640-N- 04-NNNN	HCS04.2E- W0790-N- 04-NNNN	HCS04.2E- W1010-N- 04-NNNN	HCS04.2E- W1240-N- 04-NNNN	HCS04.2E- W1540-N- 04-NNNN
<b>Performance data with high continuous load<sup>1)</sup>/high overload<sup>2)</sup></b>									
Typical motor rating	kW	132/110	160/132	200/160	250/200	315/250	400/315	500/400	630/500
	hp	200/150	250/200	300/250	400/300	500/400	600/400	700/600	900/700
Continuous current	A	259/215	300/257	366/313	459/387	586/477	720/614	894/749	1,126/930
Maximum current 60 s	A	311/323	360/386	439/470	551/581	703/716	864/921	1,073/1,124	1,351/1,395
Maximum current 2 s	A	350/355	405/424	494/516	620/639	791/787	972/1,013	1,207/1,236	1,520/1,535
Continuous input mains current <sup>3)</sup>	A	226/194	271/229	338/277	418/340	527/424	660/529	834/675	1,037/834
Mains voltage	V	3 AC 380 to 480 (+10%/-15%)							
DC bus terminal		•	•	•	•	•	•	•	•
DC bus capacity	mF	7.8	7.8	10.4	10.8	15.6	16.2	23.4	31.2
<b>Brake chopper</b>									
Brake chopper		internal	internal	internal	external	external	external	external	external
Permanent braking power	kW	85	100	120	200	200	400	400	400
Maximum brake power 10 s	kW	165	200	240	300	375	475	600	750
<b>Control voltage data</b>									
Control voltage, internal	V	DC 24 (not for supply of motor holding brake)							
Control voltage, external	V	DC 24 (±20%)							
<b>Mechanical data</b>									
Width W	mm	350	330	430	585	585	880	880	1,110
Height H	mm	782	950	950	950	950	1,150	1,150	1,150
Depth D	mm	380	380	380	380	380	380	380	380
Weight, approx.	kg	74	80	110	140	140	215	225	300

All data for nominal rating at 3 AC 400 V mains voltage and 4 kHz switching frequency with main or DC choke

<sup>1)</sup> Overload 20% for 60 s, 35% for 2 s; <sup>2)</sup> Overload 50% for 60 s, 65% for 2 s; <sup>3)</sup> With DC choke HLL

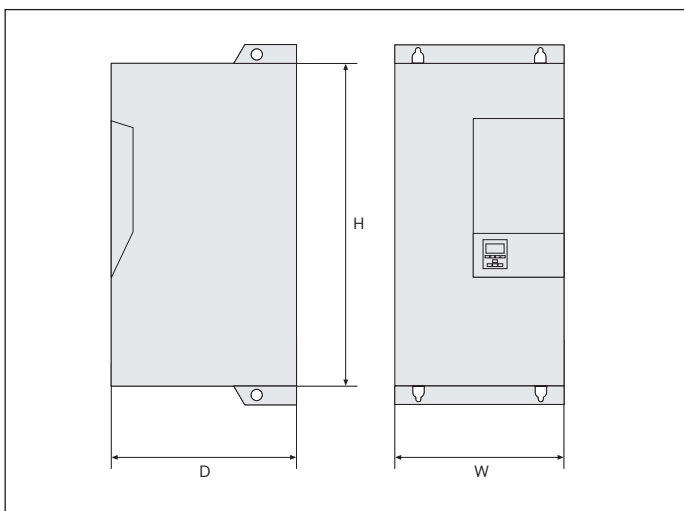

# HCS04

HCS04.2E-W0350  
 HCS04.2E-W0420  
 HCS04.2E-W0520

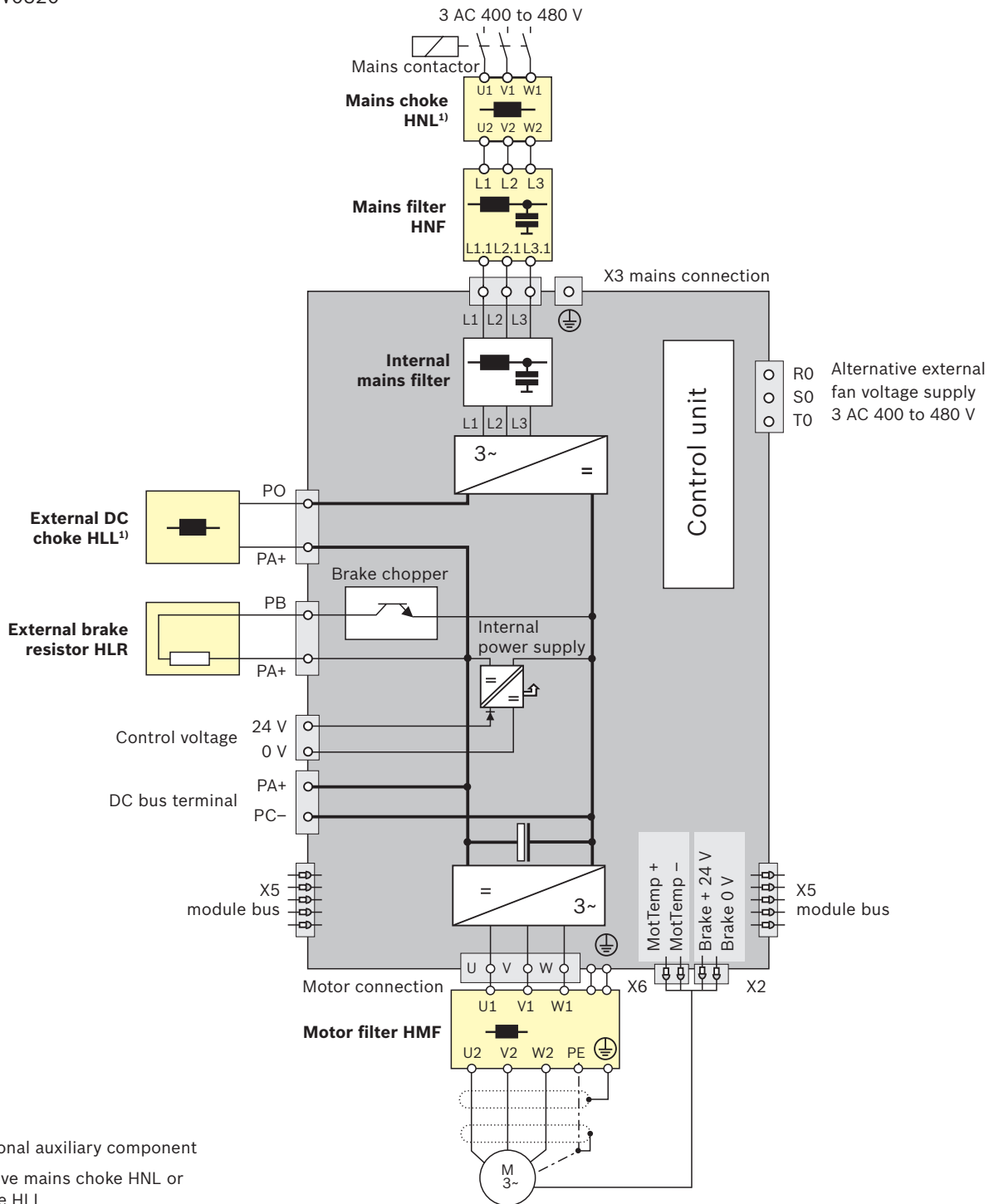

# HCS04

HCS04.2E-W0640  
 HCS04.2E-W0790  
 HCS04.2E-W1010

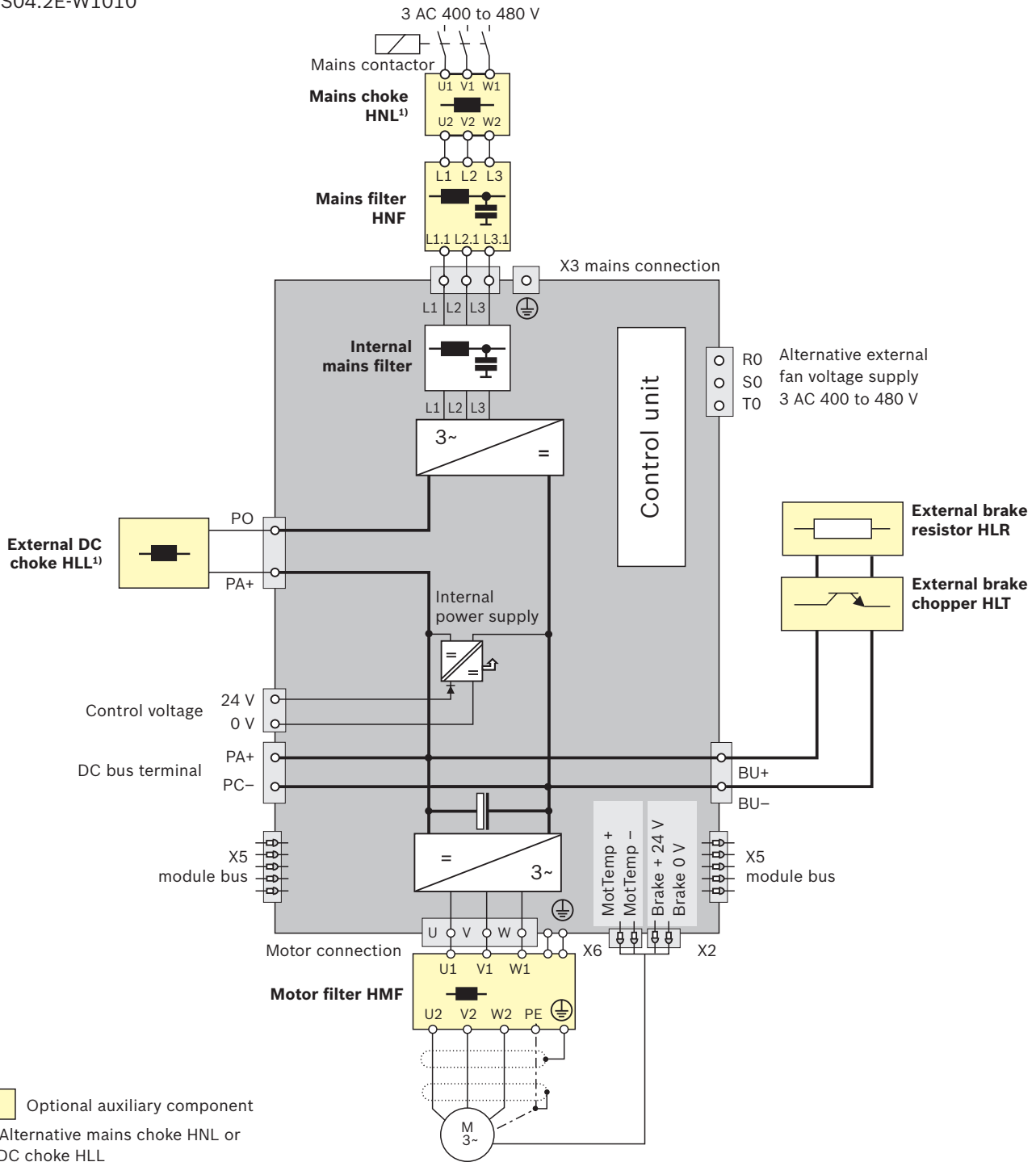

# HCS04

HCS04.2E-W1240  
HCS04.2E-W1540

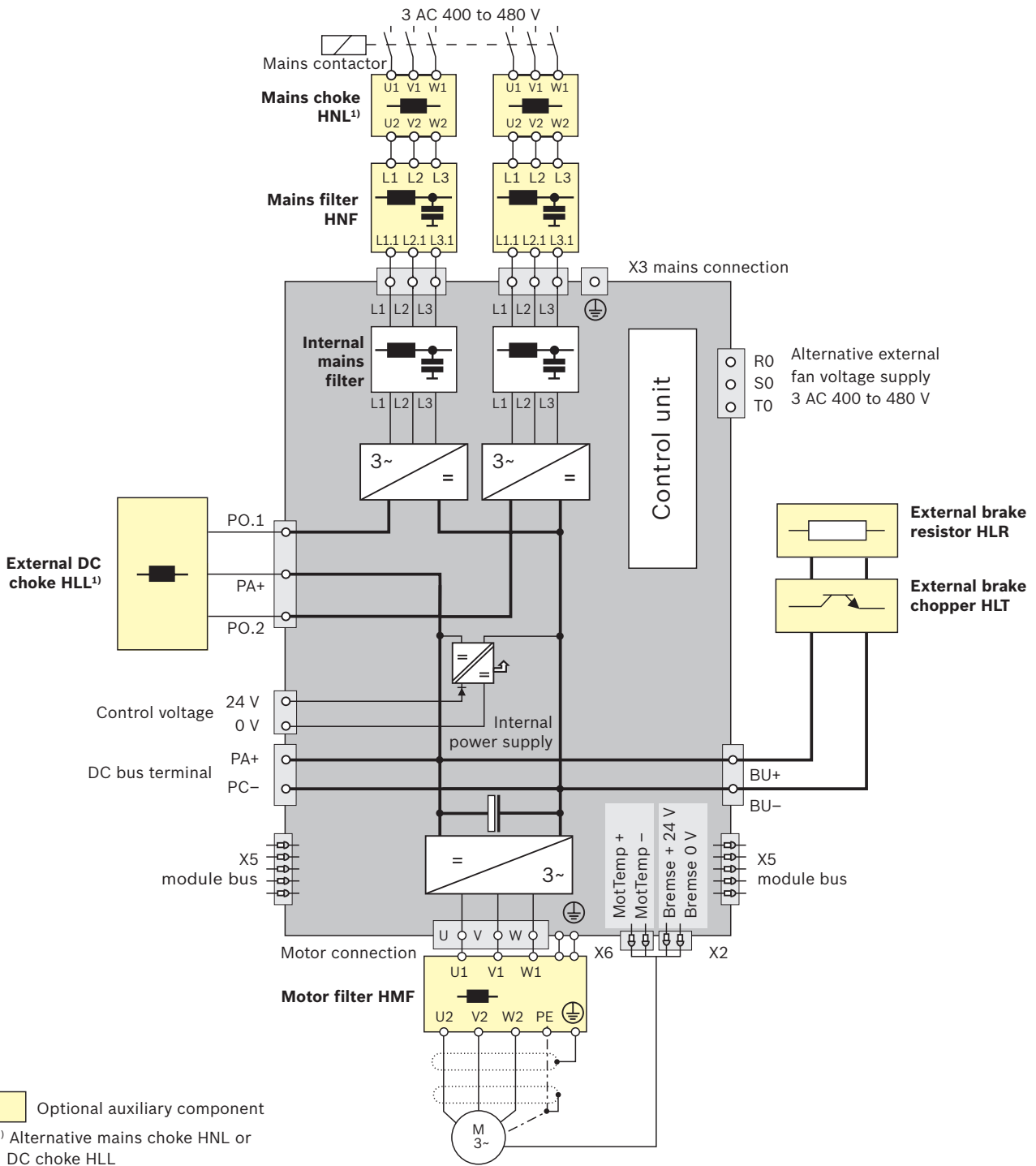

# IndraDrive M – modular single-axis inverter HMS01

		Single-axis inverter								
Model - no additional options		HMS01.1N- W0020-A- 07-NNNN	HMS01.1N- W0036-A- 07-NNNN	HMS01.1N- W0054-A- 07-NNNN	HMS01.1N- W0070-A- 07-NNNN	HMS01.1N- W0110-A- 07-NNNN	HMS01.1N- W0150-A- 07-NNNN	HMS01.1N- W0210-A- 07-NNNN	HMS01.1N- W0300-A- 07-NNNN	HMS01.1N- W0350-A- 07-NNNN
<b>Performance data</b>										
Continuous current <sup>1)</sup>	A	12,1	21,3	35	42,4	68,5	100	150	150	250
Maximum current	A	20	36	54	70	110	150	210	300	350
DC bus capacity	mF									4,9
<b>Control voltage data</b>										
Control voltage, external	V	DC 24 ±20% (DC 24 ±5% when supplying motor holding brake)								
Power consumption without control unit and motor brake	W	10	15	10	16	34	23	75	100	218 <sup>2)</sup>
Continuous current without control unit and motor brake	A	0,4	0,7	0,4	0,7	1,4	1	3,1	4,2	9,1 <sup>2)</sup>
<b>Mechanical data</b>										
Width W	mm	50	50	75	100	125	150	200	200	350
Height H	mm	440 <sup>3)</sup>								
Depth D	mm	309								
Weight	kg	5,3	5,3	6,7	7,9	11	12,7	16,4	16,4	31,7

All data apply to nominal rating at 3 AC 400 V mains voltage and 4 kHz switching frequency

<sup>1)</sup> In case of output frequency less than 4 Hz the output current will be reduced

<sup>2)</sup> Including auxiliary filter HAB

<sup>3)</sup> Overall height HSM01.1N-W0350 with auxiliary fan HAB: 748 mm

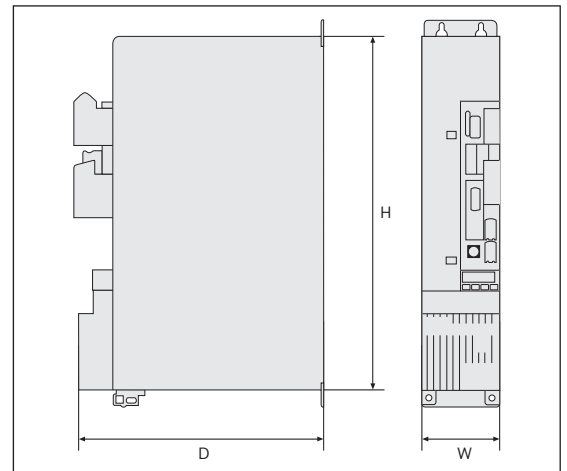



# HMS01

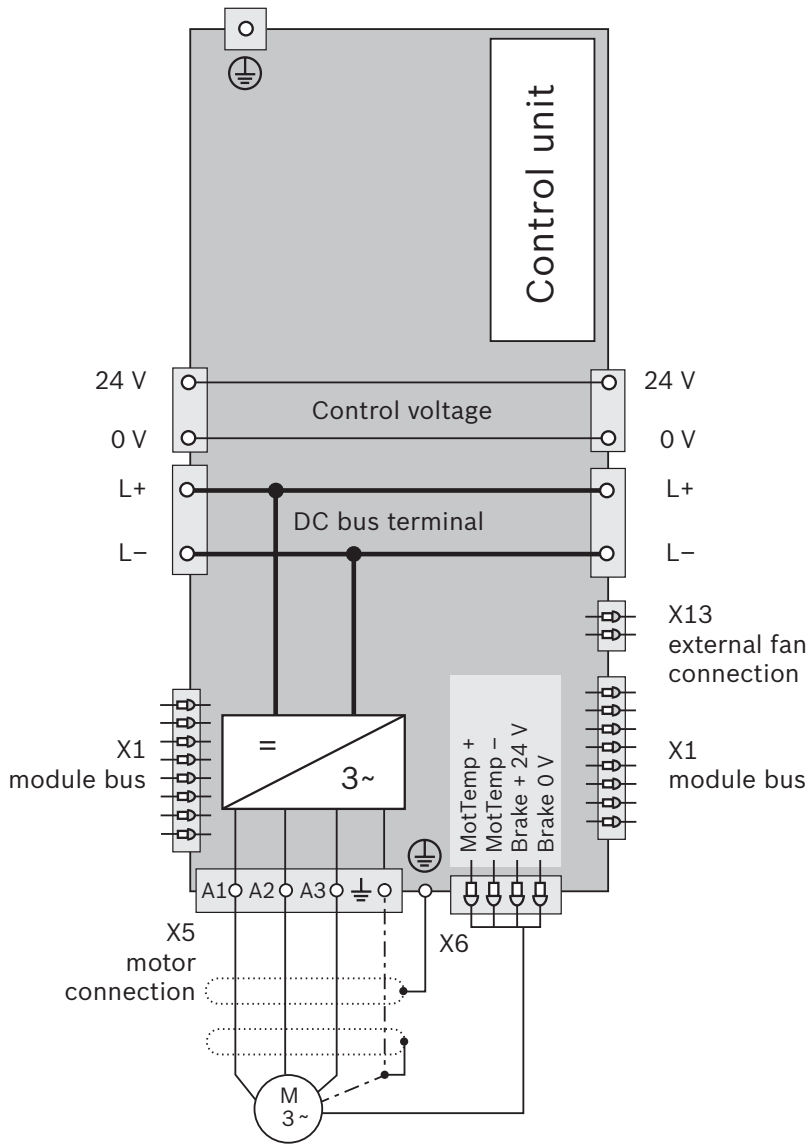

Connection X13 only with HMS01.1N-W0350

# IndraDrive M – modular single-axis inverter HMS02

		Single-axis inverter	
Model		HMS02.1N- W0028-A- 07-NNNN	HMS02.1N- W0054-A- 07-NNNN
<b>- no additional options</b>			
<b>Performance data</b>			
Continuous current <sup>1)</sup>	A	13,8	25
Maximum current	A	28	54
DC bus capacity	mF	0,14	0,27
<b>Control voltage data</b>			
Control voltage, external	V	DC 24 ±20% (DC 24 ±5% when supplying motor holding brake)	
Power consumption without control unit and motor brake	W	13	17
Continuous current without control unit and motor brake	A	0,5	0,7
<b>Mechanical data</b>			
Width W	mm	50	75
Height H	mm	352	
Depth D	mm	252	
Weight	kg	3,5	5

All data apply to nominal rating at 3 AC 400 V mains voltage and 4 kHz switching frequency

<sup>1)</sup> In case of output frequency less than 4 Hz the output current will be reduced

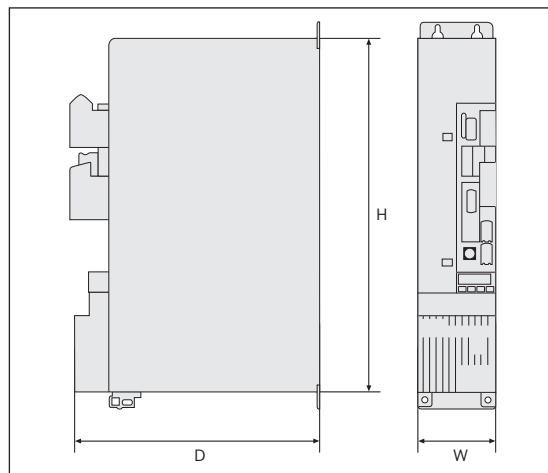

# HMS02

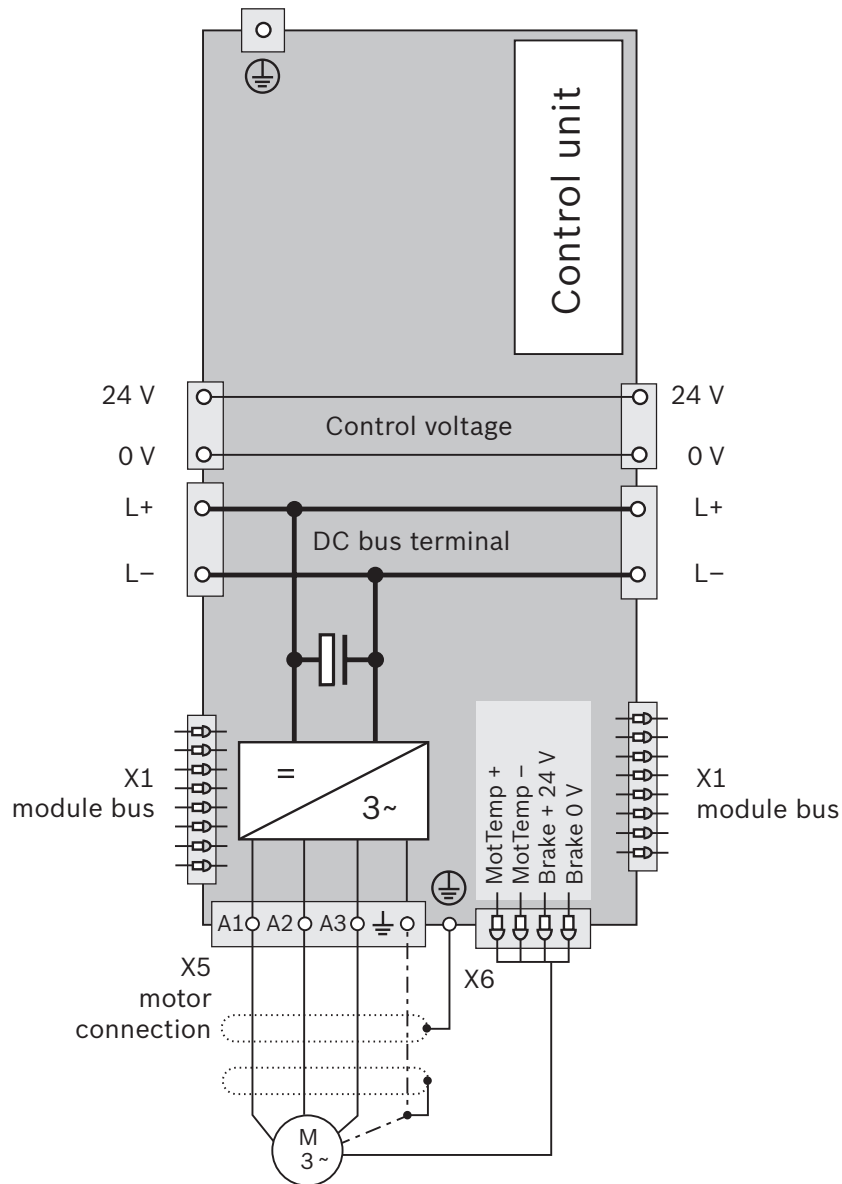

# IndraDrive M – modular double-axis inverter HMD01

Model - no additional options	Double-axis inverter			
	HMD01.1N- W0012-A- 07-NNNN	HMD01.1N- W0020-A- 07-NNNN	HMD01.1N- W0036-A- 07-NNNN	
<b>Performance data</b>				
Continuous current per inverter (axis) <sup>1)</sup>	A	7	10	20
Maximum current per inverter (axis)	A	12	20	36
<b>Control voltage data</b>				
Control voltage, external	V	DC 24 ±20% (DC 24 ±5% when supplying motor holding brake)		
Power consumption without control unit and motor brake	W	17	17	11
Continuous current without control unit and motor brake	A	0.7	0.7	0.5
<b>Mechanical data</b>				
Width W	mm	50	50	75
Height H	mm	440		
Depth D	mm	309		
Weight	kg	5.5	5.7	7.5

All data apply to nominal rating at 3 AC 400 V mains voltage and 4 kHz switching frequency

<sup>1)</sup> In case of output frequency less than 4 Hz the output current will be reduced

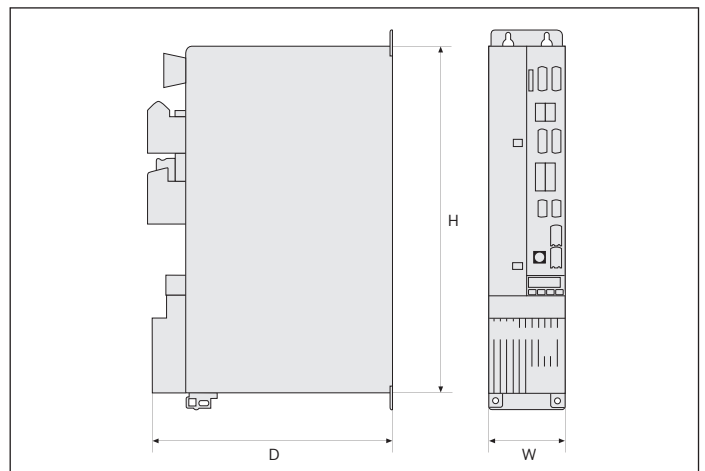

# HMD01

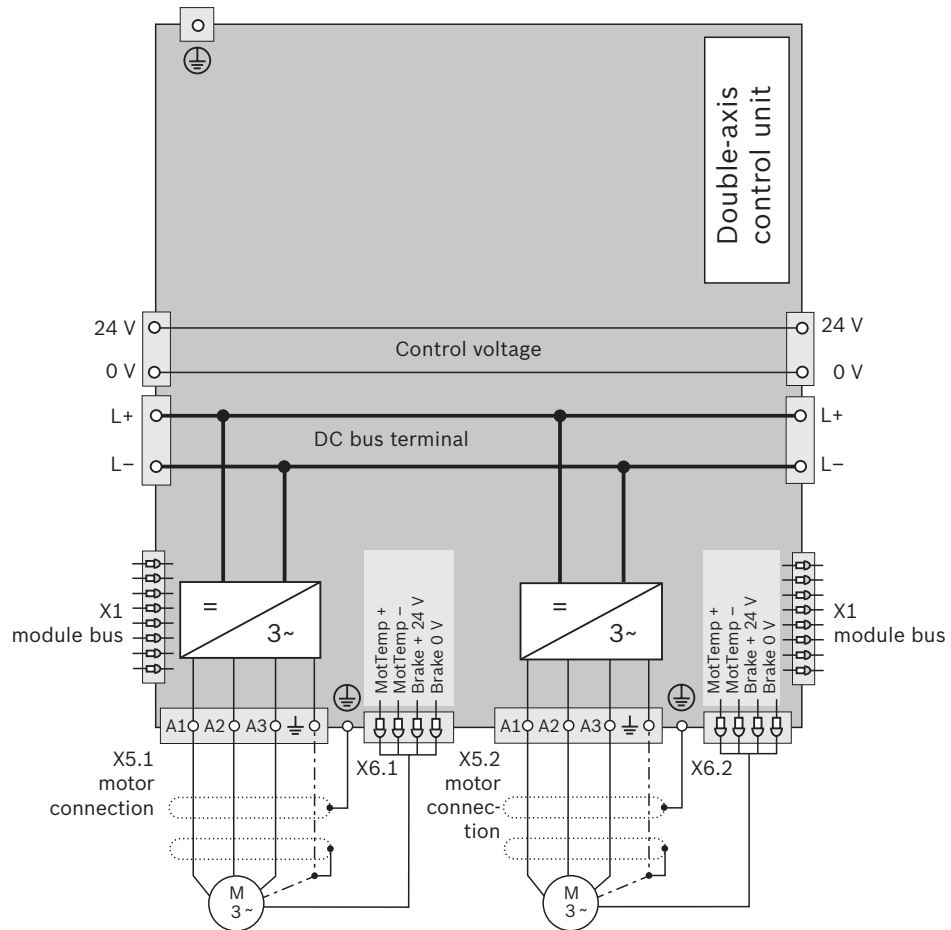

# IndraDrive M – modular power supplies HMV01 and HMV02

Model - no additional options	Infeed modules				Regenerative modules				
	HMV01.1E- W0030-A-07 -NNNN	HMV01.1E- W0075-A-07 -NNNN	HMV01.1E- W0120-A-07 -NNNN	HMV01.1R- W0018-A-07 -NNNN	HMV01.1R- W0045-A-07 -NNNN	HMV01.1R- W0065-A-07 -NNNN	HMV01.1R- W0120-A-07 -NNNN	HMV02.1R- W0015-A-07 -NNNN	
<b>Performance data</b>									
DC bus continuous power without/with choke	kW	18/30	45/75	72/120	-/18	-/45	-/65	-/120	-/15
Maximum output	kW	45	112	180	45	112	162	180	29
Mains voltage	V	3 AC 400 to 480 (+10/-15%)							
Continuous input mains current A		51	125	200	26	65	94	181	23
Dependence of output on mains voltage	at $U_{LN} < 400$ V: 1% power reduction per 4 V								
	at $U_{LN} > 400$ V: 1% power gain per 4 V				at $U_{LN} > 400$ V: no power gain				
DC bus capacity	$\mu$ F	1,410	3,760	5,640	705	1,880	2,820	4,950	700
DC bus voltage range	V	DC 435 to 710			DC 750 (regulated)				
<b>Brake resistor</b>									
Brake resistor		Internal					External	Internal	
Maximum braking energy consumption	kWs	100	250	500	80	100	150	-	40
Permanent braking power	kW	1.5	2	2.5	0.4	0.4	0.4	-	0.3
Maximum braking power	kW	36	90	130	36	90	130	-	33
<b>Control voltage data</b>									
Control voltage, external	V	DC 24 $\pm$ 5%							
Power consumption	W	25	30	55	31	41	108	224 <sup>1)</sup>	27
Continuous current	A	1	1.3	2.3	1.3	1.9	4.5	13 <sup>1)</sup>	1.1
<b>Mechanical data</b>									
Width W	mm	150	250	350	175	250	350	350	150
Height H	mm				440 <sup>2)</sup>				352
Depth D	mm				309				252
Weight	kg	13.5	22	32	13.5	20	31	34.5	9.5

In the case of the HMV01.1R the continuous output and maximum output data also apply for feedback mode.

All data apply to nominal rating at 3 AC 400 V mains voltage. Connection option for auxiliary components, such as HLB, HLC, etc.

<sup>1)</sup> Including blower unit HAB

<sup>2)</sup> Overall height HMV01.1R-W0120 with blower unit HAB: 748 mm

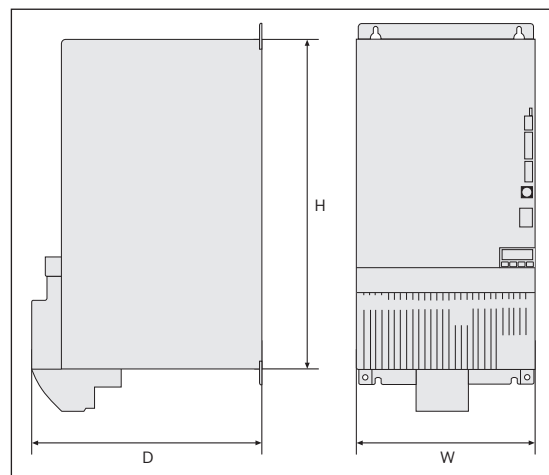

# HMV01

- HMV01.1E-W0030
- HMV01.1E-W0075
- HMV01.1E-W0120
- HMV01.1R-W0018
- HMV01.1R-W0045
- HMV01.1R-W0065

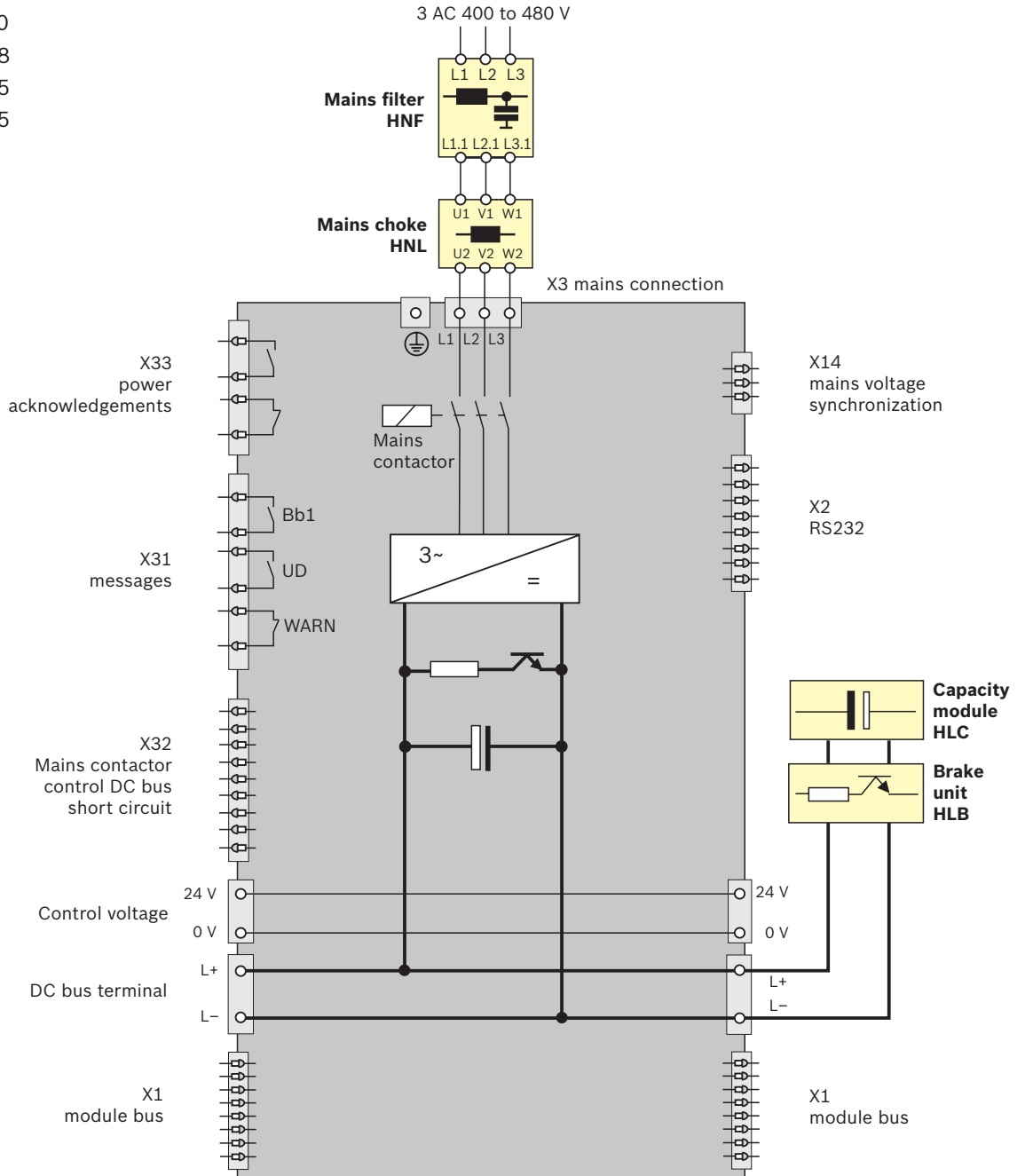

Optional auxiliary component

Mains choke HNL always required with HMV01.1R  
 Connection X14 on HMV01.1R only

# HMV01

HMV01.1R-W0120

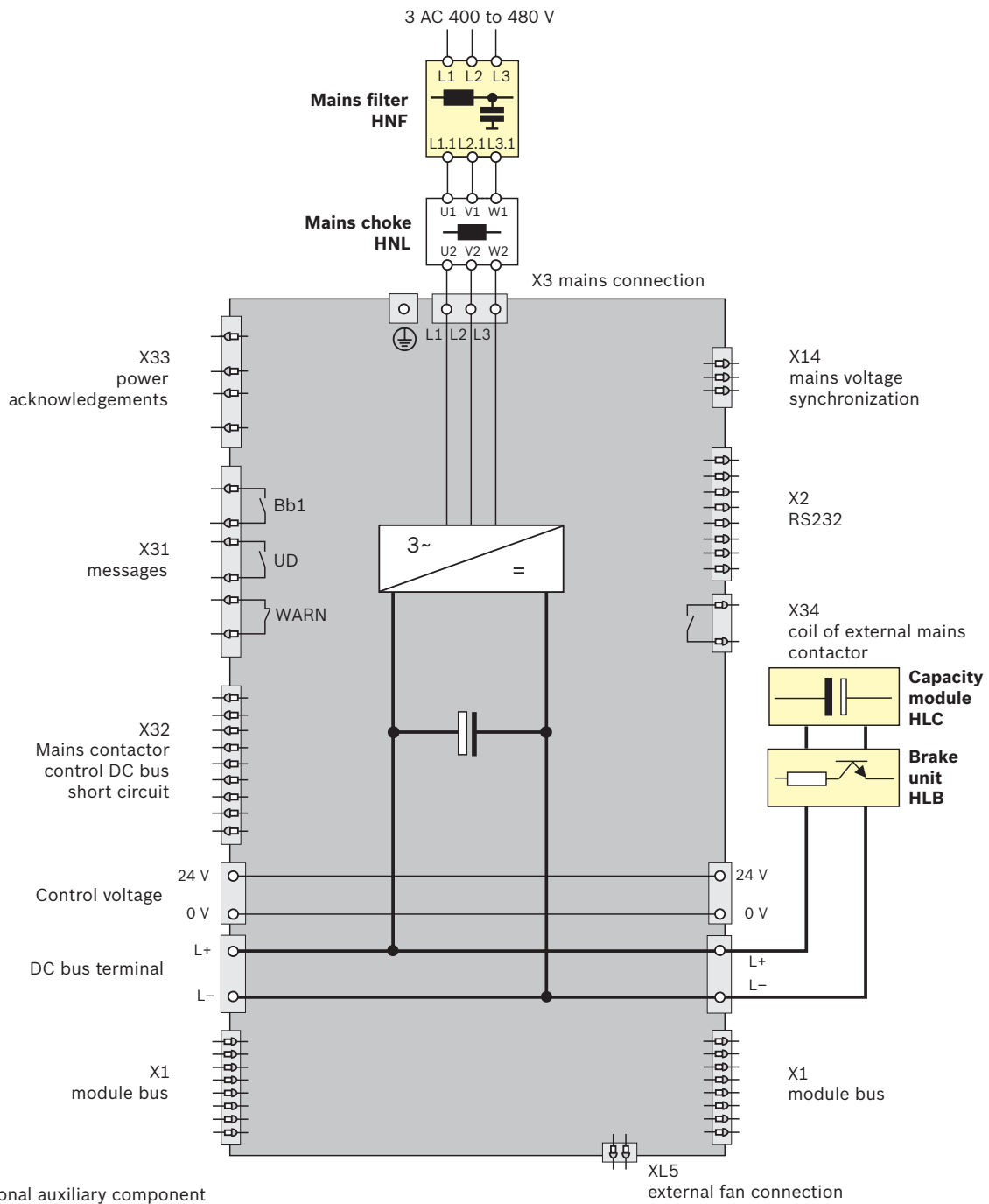



# HMV02

HMV02.1R-W0015

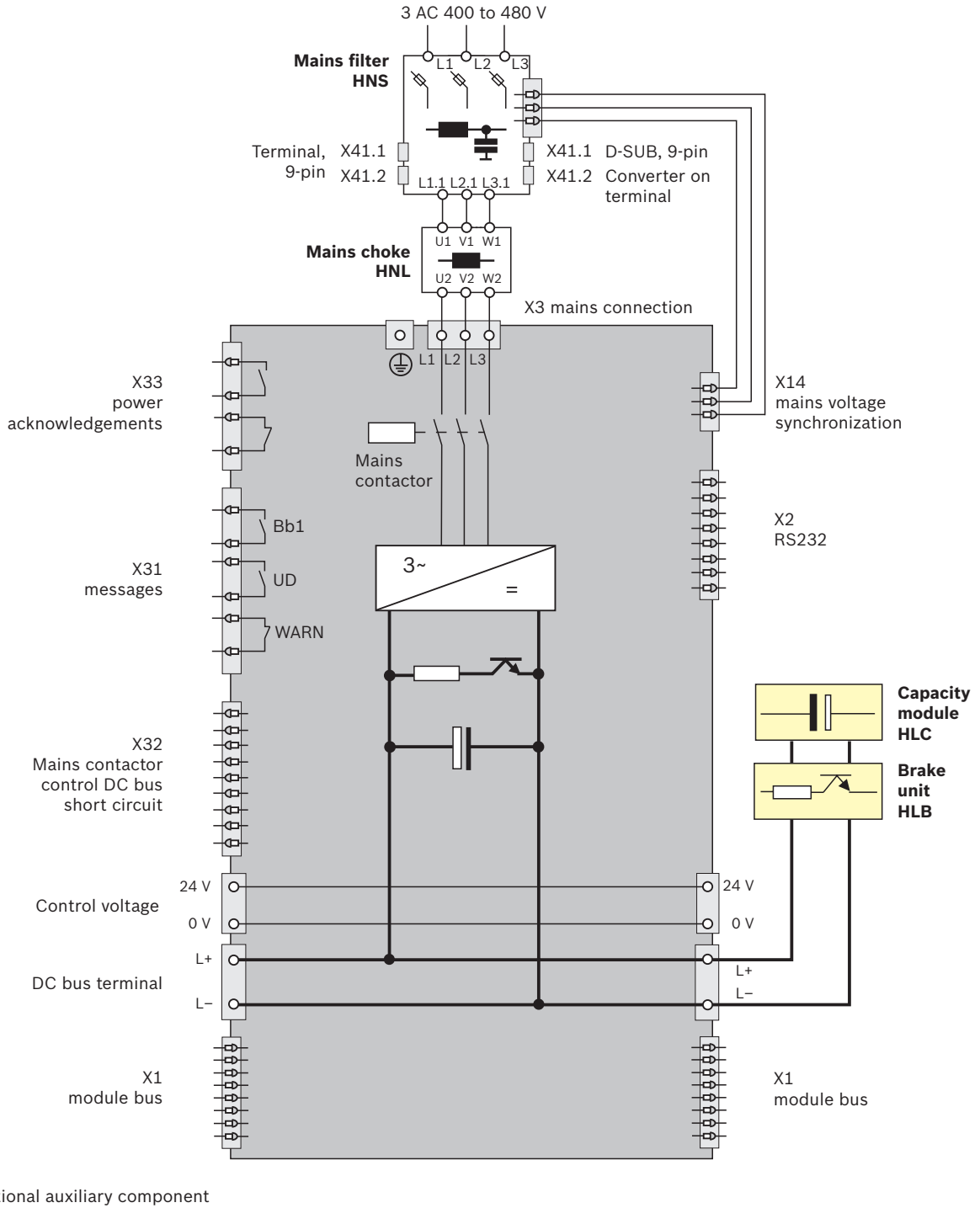

# Derating under differing operating conditions

Where installation conditions differ, the performance data of the power units decrease according to the capacity utilization factors for:

- ▶ Continuous current
- ▶ DC bus continuous output
- ▶ Permanent braking power

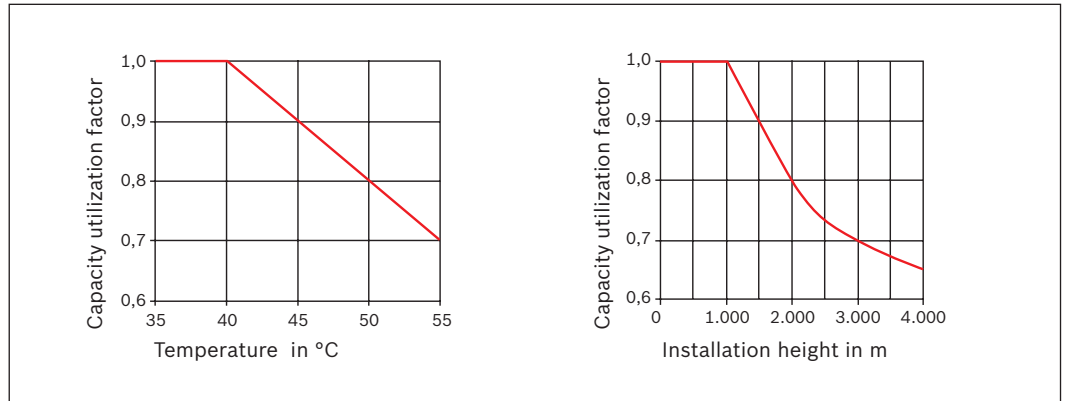

Compared with operation at 4 kHz switching frequency, the output currents of the power units decrease at higher switching frequencies. Please refer to these diagrams for the capacity utilization factors relevant for your application.

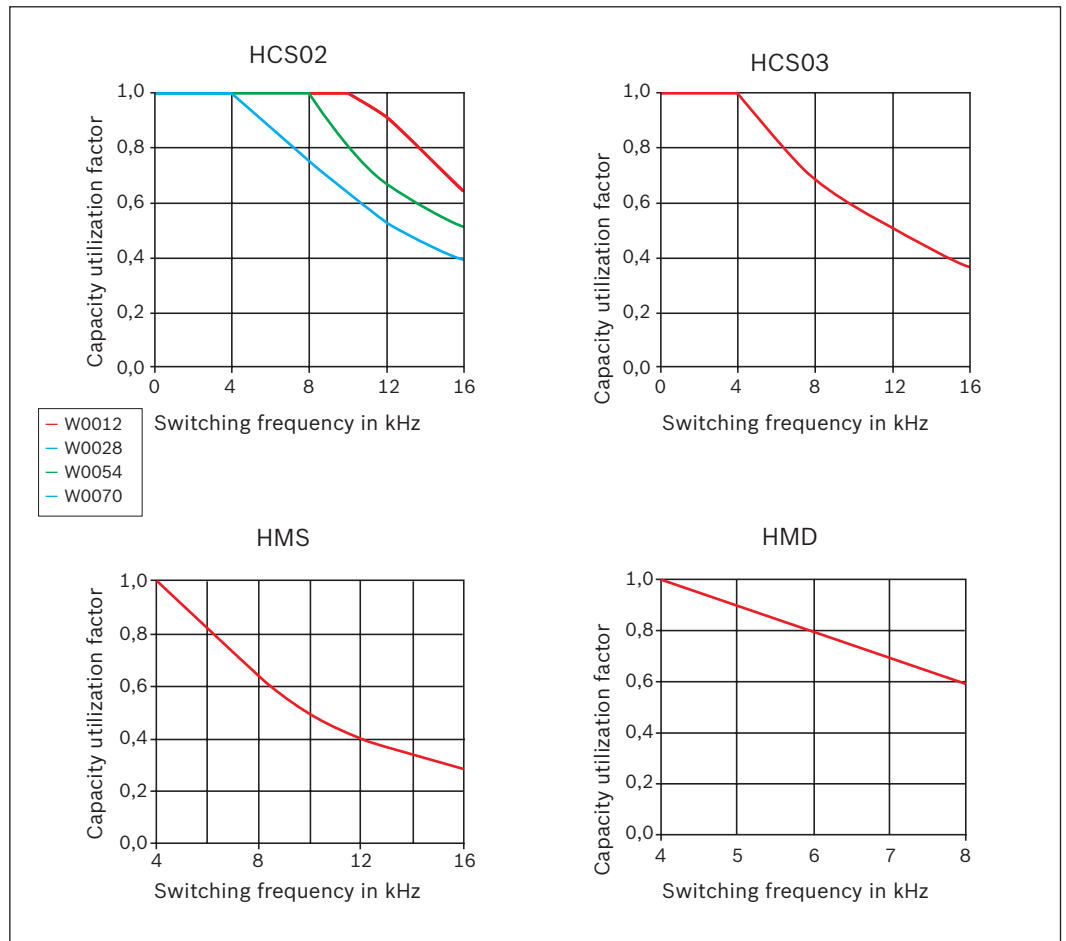



# Rexroth IndraDrive – control units



## Scalable performance and functionality

- ▶ Individual solutions for standard to high-end applications
- ▶ Integrated motion logic with innovative technology functions
- ▶ Open interfaces for international use
- ▶ Certified safety technology



We can supply control units tailored to your specific application, ranging from standard to high-end applications. Integrated motion logic, numerous technology functions, certified safety technology and standardized interfaces leave nothing to be desired.

## BASIC control units – standard performance and functionality

These control units constitute the economic solution for all standard applications with moderate requirements in terms of performance and interface flexibility. A standard encoder interface for IndraDyn motors is already featured among the BASIC control units. The BASIC UNIVERSAL control units have an additional extension slot available.

The following BASIC control units are available to choose from:

- ▶ BASIC OPEN LOOP
- ▶ BASIC ANALOG
- ▶ BASIC PROFIBUS
- ▶ BASIC SERCOS
- ▶ BASIC UNIVERSAL – single-axis
- ▶ BASIC UNIVERSAL – double-axis



## ADVANCED control units – maximum flexibility and performance

These control units meet the highest requirements in terms of performance. Virtually any application can be tackled with the wide range of communication and encoder interfaces as well as analog or digital inputs and outputs.



# IndraDrive – tailored performance and functionality

All IndraDrive control units – from the simple frequency converter to the high-end servo drive with integrated motion control – are compatible with all IndraDrive C converters and IndraDrive M inverters.

The control units differ in performance, function and configuration. When combined with the various firmware versions and operating panels, every conceivable requirement can be met. This flexible system concept opens up the full range of options when it comes to tackling your individual application – always providing the optimum technical and economical solution.

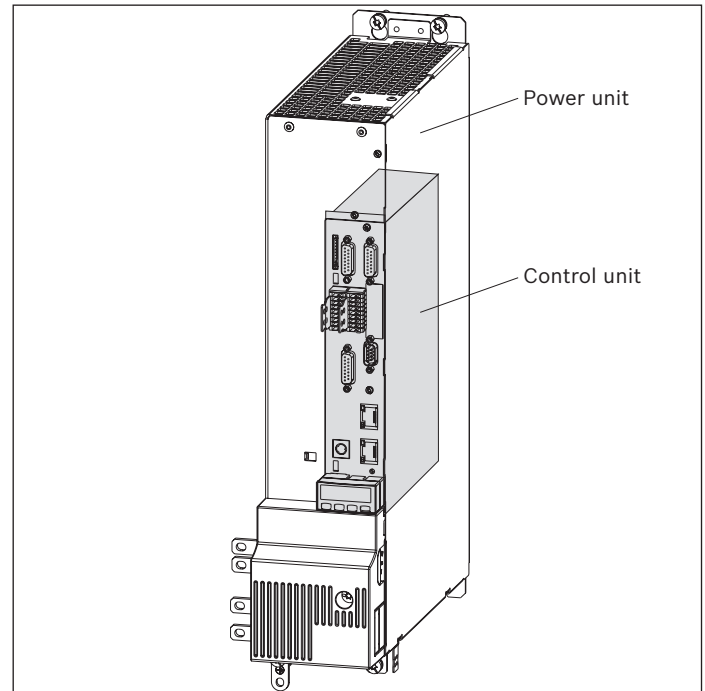

Overview	Single-axis BASIC OPEN LOOP	Single-axis BASIC ANALOG	Single-axis BASIC PROFIBUS	Single-axis BASIC SERCOS	Single-axis BASIC UNIVERSAL	Double-axis BASIC <sup>6)</sup> UNIVERSAL	Single-axis ADVANCED
<b>Control communication</b>							
Analog/digital for Open Loop operation	●	–	–	–	–	–	–
Analog interface	–	●	–	–	–	–	○ <sup>1)</sup>
Parallel interface	–	–	–	–	○	–	○
PROFIBUS	–	–	●	–	○	○	○
sercos II	–	–	–	●	○	○	○
sercos III	–	–	–	–	○	○	○
Multi-Ethernet	–	–	–	–	○	○ <sup>3)</sup>	○
CANopen	–	–	–	–	○	–	○
DeviceNet	–	–	–	–	○	–	○
<b>Configurations</b>							
Option 1	–	● <sup>2)</sup>	● <sup>2)</sup>	● <sup>2)</sup>	● <sup>2)</sup>	●/●	●
Option 2	–	–	–	–	●	●/●	●
Option 3	–	–	–	–	–	–	●
Safety option	–	●	●	●	●	●/●	●
Slot for MultiMediaCard	–	–	–	–	●	●	●

Options		Single-axis BASIC OPEN LOOP	Single-axis BASIC ANALOG	Single-axis BASIC PROFIBUS	Single-axis BASIC SERCOS	Single-axis BASIC UNIVERSAL	Double-axis BASIC <sup>6)</sup> UNIVERSAL	Single-axis ADVANCED
<b>Encoder interfaces</b>								
IndraDyn motors MSK, MKE, MAD und MAF, Hiperface <sup>®</sup> , 1 V <sub>pp</sub> and 5 V TTL <sup>4)</sup>		–	●	●	●	●	○	○
MHD and MKD motors		–	–	–	–	○	○	○
EnDat 2.1, 1 V <sub>pp</sub> and 5 V TTL <sup>5)</sup>		–	–	–	–	○	○	○
<b>Safety options compliant with EN 13849-1 and EN 62061</b>								
Safe Torque Off (category 3 PL e/SIL 3)		–	○	○	○	○	○	○
Safe Motion (category 3 PL d/SIL 2)		–	–	–	–	–	○	○
<b>Extensions</b>								
Encoder emulation		–	●	–	–	○	○	○
Analog I/O extension		–	–	–	–	○	○	○
Digital I/O extension		–	–	–	–	–	–	○
Digital I/O with SSI interface		–	–	–	–	–	–	○
Cross communication		–	–	–	–	–	–	○
<b>Software module</b>								
MultiMediaCard		–	–	–	–	○	○	○
<b>Operator panel</b>								
Standard		●	●	●	●	●	●	●
Comfort		○	○	○	○	○	○	○
<b>Cycle times</b>								
Current control	μs				125			62.5
Speed control	μs				250			125
Position control	μs				500			250
<b>PWM frequency</b>								
4/8 kHz		●/●	●/●	●/●	●/●	●/●	●/●	●/●
12/16 kHz		–/–	–/–	–/–	–/–	–/–	–/–	●/●
<b>Inputs/outputs</b>								
Digital inputs/of which utilizable for probes		8/–	5/–	5/1	5/1	5/1	18/2	7/2
Digital inputs/outputs (user-defined settings)		–	4	3	3	3	4	4
Analog inputs		2	2	–	–	–	1	1
Analog outputs		2	–	–	–	–	2	2
Relay outputs		3	1	1	1	1	1	1
<b>Interfaces</b>								
RS232		●	●	●	●	●	●	●
<b>Control voltage data</b>								
Control voltage	V				DC 24			
Power consumption without options	W	7.5	8	7.5	7.5	6.5	7.5	6
Continuous current without options	A	0.31	0.33	0.31	0.31	0.27	0.31	0.25

● Standard

○ Optional

1) In conjunction with additional options

2) Encoder interface for IndraDyn motors

3) Only with sercos III and EtherCAT

4) Supply voltage 12 V

5) Supply voltage 5 V

6) Only in connection with power unit HMD

# BASIC OPEN LOOP – for applications without an encoder

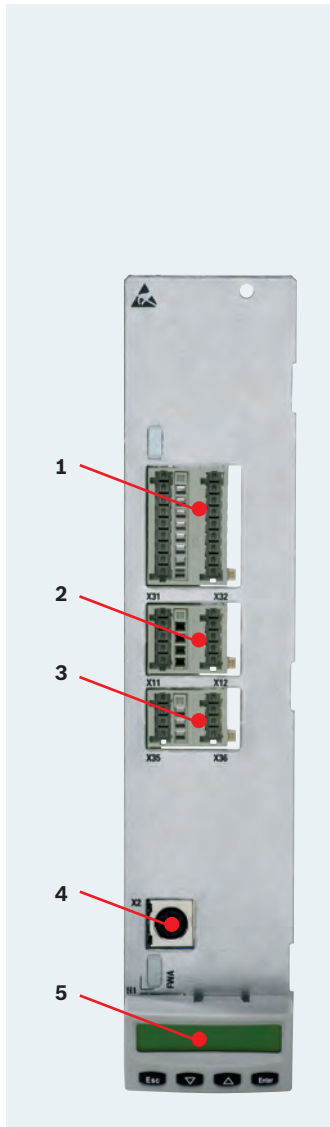

This control unit is specifically designed for frequency converter applications without an encoder.

The target speed can be set via analog or digital inputs.

Status signals and diagnostic messages are output via digital outputs or isolated relay contacts.

For an easy start-up, use the VCP 01 standard operator panel or a PC with the Rexroth IndraWorks software.

<b>1 Interfaces</b> Digital inputs and outputs Analog inputs and outputs	<b>3 Interfaces</b> Analog inputs and outputs	<b>5 Operator panel</b> Standard operator panel
<b>2 Interfaces</b> Relay outputs	<b>4 Serial interface</b> RS232	

The simple step-by-step guide to ordering your BASIC OPEN LOOP control unit:

**CSB01.1N-FC-NNN-NNN-NN-S-NN-FWW**

**Single-axis BASIC**

**Control communication**

FC = Frequency Converter Interface

**Operator panel**

S = Standard



# BASIC ANALOG – proven technology, cost-effective

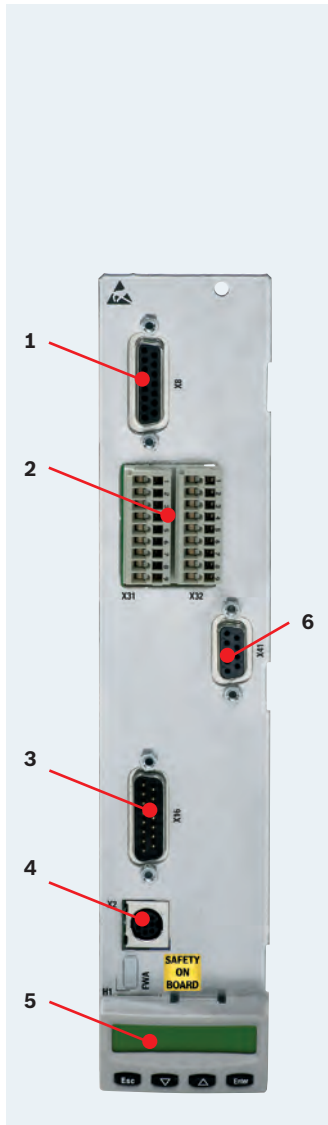

This control component allows you to enjoy the many benefits of digital drive technology on controls with the conventional  $\pm 10$  V analog interface. In addition, it gives you the added option of expanding your control equipment at any time to include other communication interfaces by exchanging the control component while retaining the control cabinet setup.

The default speed is set via the analog input. Signals, such as “Control enable” or “Drive stop”, are exchanged by the control system and control unit via digital inputs and outputs. The encoder emulation inside the drive systematizes the actual positions for the control system. There is a choice between the straightforward incremental encoder signal or SSI format.

The correct interface for connecting the IndraDyn motors or other standardized encoders, such as Hiperface®, is already integrated.

<b>1 Encoder interface</b> IndraDyn motors, Hiperface®, 1 V <sub>pp</sub> and 5 V TTL	<b>3 Encoder emulation</b>	<b>5 Operator panel</b> Standard operator panel
<b>2 Interfaces</b> Digital inputs and outputs Analog inputs Relay output	<b>4 Serial interface</b> RS232	<b>6 Safety option</b> Safe Torque Off



The simple step-by-step guide to ordering your BASIC ANALOG control unit:

**CSB01.1N-AN-ENS-NNN-L2-S-NN-FW**

**Single-axis BASIC**

**Control communication**

AN = Analog interface

**Encoder interface**

ENS = IndraDyn motors, Hiperface®, etc.

**Operator panel**

S = Standard

**Safety technology**

L2 = Safe Torque Off

NN = No safety technology

# BASIC PROFIBUS – ideal for factory automation

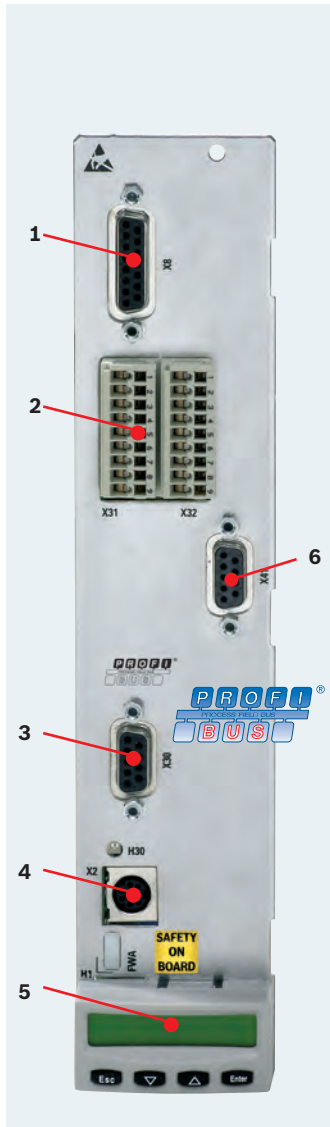

The PROFIBUS fieldbus interface has been used successfully for many years in automated manufacturing technology and process automation. This bus system is the means by which the control system cyclically exchanges with the bus users all the specified and actual values, including status signals and diagnostic messages. The correct interface for connecting the IndraDyn motors or other standardized encoders, such as Hiperface®, is already integrated. Start-up with the IndraWorks engineering tool is a convenient option via PROFIBUS.

<b>1 Encoder interface</b> IndraDyn motors, Hiperface®, 1 V <sub>pp</sub> and 5 V TTL	<b>3 Control communication</b> PROFIBUS	<b>5 Operator panel</b> Standard operator panel
<b>2 Interfaces</b> Digital inputs and outputs Relay output	<b>4 Serial interface</b> RS232	<b>6 Safety option</b> Safe Torque Off



The simple step-by-step guide to ordering your BASIC PROFIBUS control unit:

**CSB01.1N-PB-ENS-NNN-L2-S-NN-FW**

**Single-axis BASIC**

**Control communication**

PB = PROFIBUS

**Encoder interface**

ENS = IndraDyn motors, Hiperface®, etc.

**Operator panel**

S = Standard

**Safety technology**

L2 = Safe Torque Off

NN = No safety technology

# BASIC SERCOS – precise and cost-effective

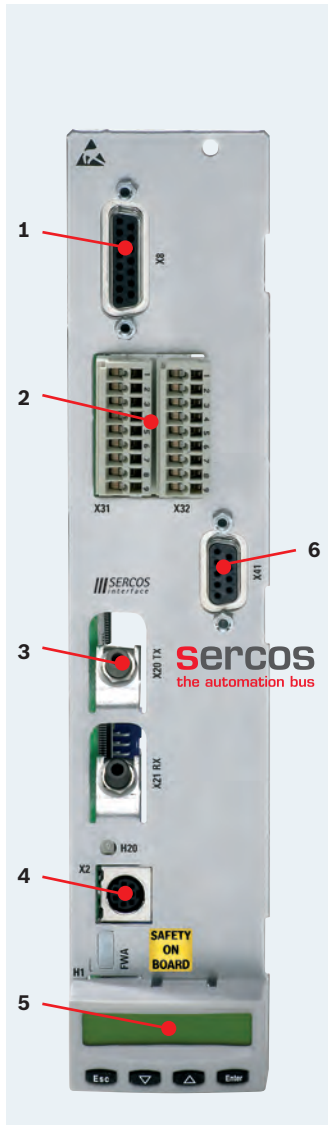

Only sercos II<sup>1)</sup> lets you enjoy all the advantages of digital intelligent drive technology. One distinguishing feature of sercos II is its extremely short cycle time required for the transfer of all target and actual values between the control system and control units. In conjunction with the exact synchronization of all drives, sercos II guarantees maximum dynamics and precision.

Signal transfer via fiber optics guarantees the secure exchange of real-time data with minimal wiring.

The correct interface for connecting the IndraDyn motors or other standardized encoders, such as Hiperface®, is already integrated.

With the engineering tool, IndraWorks, one convenient start-up option is via the sercos service channel and the other is via the RS232 interface.

<sup>1)</sup> sercos II, the internationally standardized drive interface (IEC 61491/EN 61491), facilitates optimum compatibility of digital drives and controls made by different manufacturers while exploiting the respective product attributes to maximum effect.

<b>1 Encoder interface</b> IndraDyn motors, Hiperface®, 1 V <sub>pp</sub> and 5 V TTL	<b>3 Control communication</b> sercos II	<b>5 Operator panel</b> Standard operator panel
<b>2 Interfaces</b> Digital inputs and outputs Relay output	<b>4 Serial interface</b> RS232	<b>6 Safety option</b> Safe Torque Off

**SAFETY ON BOARD**

The simple step-by-step guide to ordering your BASIC SERCOS control unit:

**CSB01.1N-SE-ENS-NN-L2-S-NN-FW**

**Single-axis BASIC**

**Control communication**

SE = sercos II

**Encoder interface**

ENS = IndraDyn motors, Hiperface®, etc.

**Operator panel**

S = Standard

**Safety technology**

L2 = Safe Torque Off

NN = No safety technology

# BASIC UNIVERSAL single-axis – flexible for customized solutions

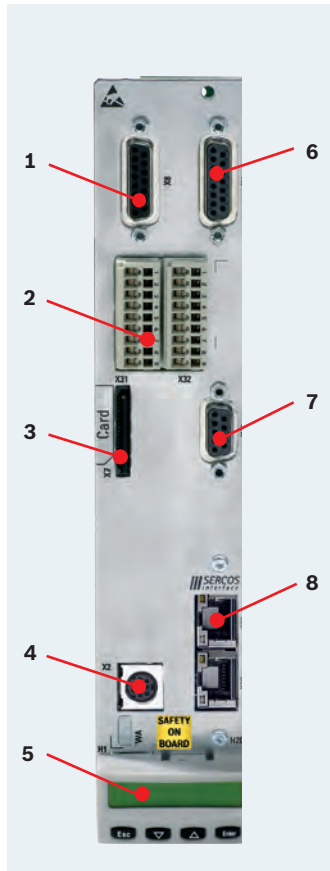

Regardless of your preferred type of control communication, BASIC UNIVERSAL offers you a wide range of industry-standard interfaces. As a result, this control unit is well suited for a variety of applications – including those in your industry.

The correct interface for connecting the IndraDyn motors or other standardized encoders, such as Hiperface®, is already integrated. In addition, this control unit has an empty slot for the connection of another encoder, connection of the analog I/O extension or for the emission of emulated encoder signals.

An additional plug-in MultiMediaCard gives you the option of simple transmission or duplication of your drive parameters. This card can also be used to expand the memory for the motion logic integrated in the drive (firmware option).

For an easy start-up use a PC with the Rexroth IndraWorks software.

<b>1 Encoder interface</b> IndraDyn motors, Hiperface®, 1 V <sub>pp</sub> and 5 V TTL	<b>3 Slot</b> MultiMediaCard		<b>6 Option</b> Encoder interfaces Analog I/O extension Encoder emulation
<b>2 Interfaces</b> Digital inputs and outputs Relay output	<b>4 Serial interface</b> RS232		<b>7 Safety option</b> Safe Torque Off
	<b>5 Operator panel</b> Standard operator panel		<b>8 Control communication</b> sercos III PROFIBUS, etc.



The simple step-by-step guide to ordering your BASIC UNIVERSAL single-axis control unit:

**CSB01.1C-SE-ENS-NNN-L2-S-NN-FW**

**Single-axis BASIC UNIVERSAL**

**Control communication**

- SE = sercos II
- PB = PROFIBUS
- PL = Parallel interface
- CO = CANopen, DeviceNet
- S3 = sercos III
- ET = Multi-Ethernet
- NN = Not equipped

**Encoder interface**

ENS = IndraDyn motors, Hiperface®, etc.

**Operator panel**

S = Standard

**Safety technology**

- L2 = Safe Torque Off
- NN = No safety technology

**Option**

- ENS = IndraDyn motors, Hiperface®, etc.
- EN1 = MHD, MKD motors
- EN2 = EnDat 2.1, 1 V<sub>pp</sub>, 5 V TTL
- MA1 = Analog I/O extension
- MEM = Encoder emulation
- NNN = Not equipped

# BASIC UNIVERSAL double-axis – flexible, safe, space-saving

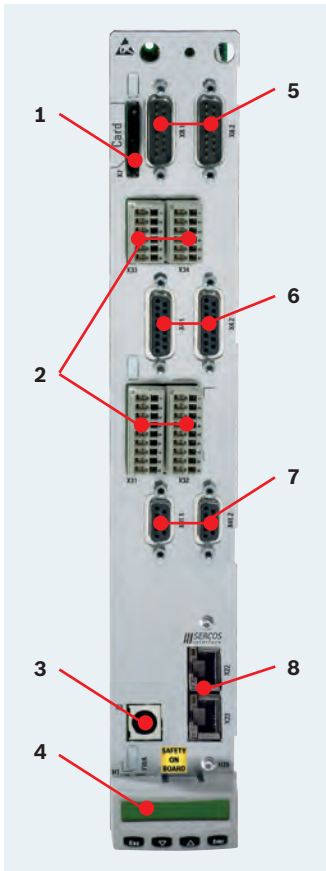

Many axes and limited installation space – these are typical requirements that can be met competently and economically with the BASIC UNIVERSAL double-axis control unit. With the BASIC UNIVERSAL double-axis, we have implemented all the functionality for two digital axes in a single control unit.

With certified safety technology conforming to EN 13849-1 and EN 62061, you are providing effective protection for both the machine and operator. Indeed, we have integrated a number of different safety functions, directly in the drive. This increases reliability while saving on monitoring components and minimizing installation work. In terms of control communication you can choose between sercos II, PROFIBUS, sercos III and Multi-Ethernet. In the interests of meeting the specific demands of your individual application, IndraDrive offers additional options for the connection of various encoder systems, the connection of an analog I/O extension or for the emission of emulated encoder signals. The double-axis control unit offers the ability of storing the axis-oriented drive parameters of both axes on the optional MultiMediaCard.

<b>1 Slot</b> MultiMediaCard		<b>3 Serial interface</b> RS232	<b>6 Option 1 and 2</b> Encoder interfaces
<b>2 Interfaces</b> Digital inputs and outputs Analog inputs and outputs Relay output	<b>5 Option 3 and 4</b> Encoder interfaces Analog I/O extension Encoder emulation	<b>4 Operator panel</b> Standard operator panel	<b>7 Safety option</b> Safe Torque Off Safe Motion
			<b>SAFETY ON BOARD</b>
			<b>8 Control communication</b> sercos III PROFIBUS, etc.

The simple step-by-step guide to ordering your BASIC UNIVERSAL double-axis control unit:

**CDB01.1C-SE-ENS-EN2-NNN-MA1-S2-S-NN-FW**

**Double-axis BASIC UNIVERSAL**

**Control communication**

- SE = sercos II
- PB = PROFIBUS
- S3 = sercos III
- ET = Multi-Ethernet
- NN = Not equipped

**Option 1 and 2**

- ENS = IndraDyn motors, Hiperface®, etc.
- EN1 = MHD, MKD motors
- EN2 = EnDat 2.1, 1 V<sub>pp</sub>, 5 V TTL
- NNN = Not equipped

**Operator panel**

S = Standard

**Safety technology**

- L2 = Safe Torque Off
- S2 = Safe Motion
- NN = No safety technology

**Option 3 and 4**

- ENS = IndraDyn motors, Hiperface®, etc.
- EN1 = MHD, MKD motors
- EN2 = EnDat 2.1, 1 V<sub>pp</sub>, 5 V TTL
- MA1 = Analog I/O extension
- MEM = Encoder emulation NNN = Not equipped

# ADVANCED – the security of maximum performance and flexibility

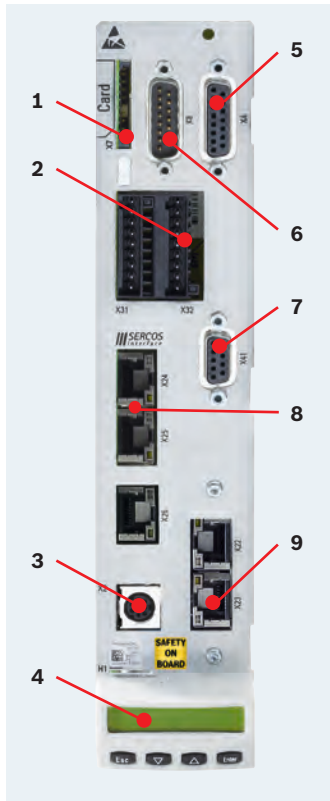

ADVANCED control units meet the highest demands in performance and dynamics. In addition to top performance, they support a wide and diverse range of control communication and encoder interfaces. Digital and analog inputs and outputs are already permanently integrated for communication with higher level control systems. These can also be expanded by digital or analog I/O extensions or by encoder emulation outputs. This high-performance control unit can be optionally equipped with safety technology certified as conforming to EN 13849-1 and EN 62061. The ADVANCED control unit is the ideal platform for the drive-integrated PLC, IndraMotion MLD. All that is required to start up the drive is a PC and the engineering tool IndraWorks.

<p><b>1 Slot</b> MultiMediaCard</p> 	<p><b>5 Option 1</b> Encoder interfaces</p>	<p><b>8 Option 3</b> Encoder interfaces Analog I/O extension Encoder emulation Digital I/O extension Cross communication</p>
<p><b>2 Interfaces</b> Digital inputs and outputs Analog inputs and outputs Relay output</p>	<p><b>6 Option 2</b> Encoder interfaces I/O extension Encoder emulation</p>	
<p><b>3 Serial interface</b> RS232</p>	<p><b>7 Safety option</b> Safe Torque Off Safe Motion</p>	<p><b>SAFETY ON BOARD</b></p>
<p><b>4 Operator panel</b> Standard operator panel</p>		<p><b>9 Control communication</b> sercos III PROFIBUS, etc.</p>

The simple step-by-step guide to ordering your ADVANCED control unit:

## CSH01.1C-SE-ENS-EN2-NNN-S2-S-NN-FW

### Single-axis ADVANCED

#### Control communication

- SE = sercos II
- PB = PROFIBUS
- PL = Parallel interface
- CO = CANopen, DeviceNet
- S3 = sercos III
- ET = Multi-Ethernet
- NN = Not equipped

#### Option 1 (encoder interface)

- ENS = IndraDyn motors, Hiperface®, etc.
- EN1 = MHD, MKD motors
- EN2 = EnDat 2.1, 1 V<sub>pp</sub>, 5 V TTL
- NNN = Not equipped

#### Operator panel

- S = Standard
- Safety technology**
- L2 = Safe Torque Off
- S2 = Safe Motion
- NN = No safety technology

#### Option 3

- ENS = IndraDyn motors, Hiperface®, etc.
- EN1 = MHD, MKD motors
- EN2 = EnDat 2.1, 1 V<sub>pp</sub>, 5 V TTL
- MA1 = Analog I/O extension
- MEM = Encoder emulation
- MD1 = Digital I/O extension
- MD2 = Digital I/O with SSI encoder interface
- CCD = Cross communication
- NNN = Not equipped

# Accessories – add-ons for your control unit

These components can help you to capitalize on your drive – during start-up, operation and diagnostics.

## Operator panel

All control units are equipped with a standard plug-in operating panel. This will guide you quickly and confidently through all the start-up steps – no PC is required.

## Separate control terminals

For complex applications, especially in conjunction with the drive-integrated motion logic, we recommend the use of our compact control terminals IndraControl VCP.

Connection is via the drive's serial interface.

From the simple text display right through to the graphics-capable touch screen, they always provide a particularly cost-effective solution for operation and visualization.

For more detailed information, please refer to the product catalog “Automation Systems and Control Components” (R911320438).



## Software module

The optional MultiMediaCard allows you to transmit or duplicate your axis-oriented drive parameters quickly and easily – without a PC.

This software module comes in two versions:

- ▶ PFM02.1-016-NN-FW with drive firmware
- ▶ PFM02.1-016-NN-NW preformatted for simple parameter transfer



## Interface cable

For start-up or operation connect your PC or a separate control terminal directly to the RS232 serial interface of the control unit.

- ▶ The pre-assembled PC interface cable IKB0041 is available in lengths of 2, 5, 10 or 15 m.
- ▶ The RKB0004 operator terminal cable is available in lengths of 2, 5 and 10 m.



# Overview of interfaces

## Control communication

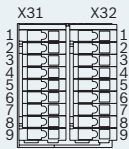

Analog/digital for Open Loop operation

- 2 x 9-pin plug-in terminals
- ▶ 8 digital inputs

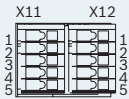

- 2 x 5-pin plug-in terminals
- ▶ 3 relay outputs (24 V DC and 230 V AC)



- 2 x 4-pin plug-in terminals
- ▶ 2 analog inputs
- ▶ 2 analog outputs



**sercos II**

- 2 x fiber optic cable connections
- ▶ Choice of transfer rates 2, 4, 8 or 16 Mbaud

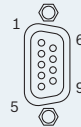

**PROFIBUS**

D-SUB, 9-pin, female version

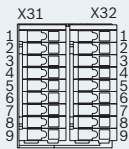

**Analog interface**

- 2 x 9-pin plug-in terminals
- ▶ Analog inputs  $\pm 10$  V
- ▶ Digital inputs/outputs
- ▶ Relay output

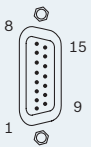

- D-SUB, 15-pin, male version
- ▶ Encoder emulation, incremental or absolute (SSI)
- ▶ Output frequency max. 1 MHz



**CANopen/DeviceNet**

- Open-style connector, 5-pin
- ▶ Selector switch for CANopen or DeviceNet

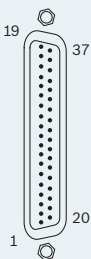

**Parallel interface**

- D-SUB, 37-pin, male version
- ▶ 16 inputs, reverse polarity protected
- ▶ 16 outputs, short-circuit proof
- ▶ DC-isolated

(Also suitable for input/output extension in conjunction with IndraMotion MLD)



**sercos III**



- 2 x RJ45 plug-in connection



**Multi-Ethernet**

- 2 x RJ45 plug-in connection
- ▶ sercos III
- ▶ PROFINET IO
- ▶ EtherNet/IP
- ▶ EtherCAT

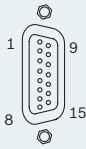
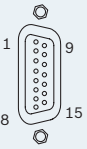
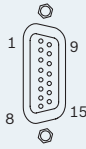
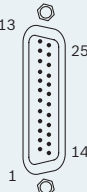
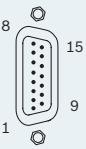
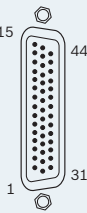

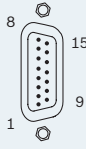
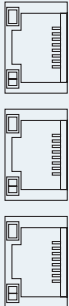
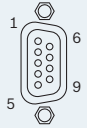
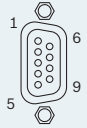
Encoder interfaces	Input/output extensions
 <p><b>ENS</b> encoder interfaces for IndraDyn motors, Hiperface®, 1 V<sub>pp</sub>, 5 V TTL</p> <p>D-SUB, 15-pin, female version</p> <ul style="list-style-type: none"> <li>▶ Encoder supply: 11.6 V/300 mA</li> </ul>	 <p>Analog I/O extension <b>MA1</b></p> <p>D-SUB, 15-pin, female version</p> <ul style="list-style-type: none"> <li>▶ 2 analog input ports ±10 V</li> <li>▶ 14 bit incl. 8-time oversampling</li> <li>▶ 2 analog 12 bit output ports</li> </ul>
 <p><b>EN1</b> encoder interface for MHD and MKD motors</p> <p>D-SUB, 15-pin, female version</p> <ul style="list-style-type: none"> <li>▶ Encoder supply I2C: 8 V/250 mA or resolver: 18.2 V/70 mA</li> </ul>	 <p>Digital I/O extension <b>MD1</b></p> <p>D-SUB, 25-pin, male version</p> <ul style="list-style-type: none"> <li>▶ External voltage supply from 19 V to 30 V</li> <li>▶ 12 inputs, reverse polarity protected</li> <li>▶ 8 outputs, short-circuit proof</li> </ul>
 <p><b>EN2</b> encoder interface for EnDat 2.1, 1 V<sub>pp</sub>, 5 V TTL</p> <p>D-SUB, 15-pin, male version</p> <ul style="list-style-type: none"> <li>▶ Encoder supply: 5 V/300 mA</li> </ul>	 <p>Digital I/O with SSI interface <b>MD2</b></p> <p>D-SUB, 44-pin, male version</p> <ul style="list-style-type: none"> <li>▶ External voltage supply from 19 V to 30 V</li> <li>▶ 16 inputs, reverse polarity protected</li> <li>▶ 16 outputs, short-circuit proof</li> </ul>  <p>RJ11 plug-in connection for SSI measuring encoder interface</p>
Encoder emulation	
 <p>Encoder emulation <b>MEM</b></p> <p>D-SUB, 15-pin, male version</p> <ul style="list-style-type: none"> <li>▶ Internal voltage supply</li> <li>▶ Encoder signals DC-isolated</li> <li>▶ Incremental or Absolute (SSI format)</li> <li>▶ Output frequency max. 1 MHz</li> </ul>	<h3 data-bbox="1125 1406 1220 1438">Safety</h3>
Cross communication	
 <p>Cross communication <b>CCD</b></p> <p>3 x RJ45 plug-in connection</p> <ul style="list-style-type: none"> <li>▶ Master for connection of up to 9 slaves (sercos III)</li> <li>▶ Ethernet engineering interface</li> </ul>	 <p>Safe Torque Off <b>L2</b></p> <p>D-SUB, 9-pin, female version</p> <ul style="list-style-type: none"> <li>▶ Supply voltage 24 V DC</li> <li>▶ Drive signals A, B and inverse</li> <li>▶ Acknowledgement</li> <li>▶ Acknowledgement, inverse</li> </ul>
 <p>Safe Motion <b>S2</b></p> <p>D-SUB, 9-pin, female version</p> <ul style="list-style-type: none"> <li>▶ Supply voltage 24 V DC</li> <li>▶ Mode selection panel inputs</li> <li>▶ Acknowledgement, forced dormant error detection and diagnostics/ safety door lock</li> </ul>	

# IndraDrive Cs – compact multi-protocol drive system



## Highly versatile, extremely compact drives

- ▶ Power range from 100 W to 9 kW
- ▶ Ethernet-based communications, multi-protocol support
- ▶ Innovative multi-encoder interface
- ▶ Extremely compact design
- ▶ Optional integrated safety technology



## IndraDrive Cs – compact drives featuring Ethernet-based communications

The IndraDrive Cs offers new communications hardware with multi-protocol support which addresses today's increased need for open, seamless design.

The drives support SERCOS III, PROFINET IO, EtherNet/IP and EtherCat. Connectivity via these Ethernet-based interfaces is provided by software-configurable communications hardware. Alternatively IndraDrive Cs can also be supplied with a conventional communications interface, for example PROFIBUS. The Rexroth solution gives users maximum communications flexibility with minimum engineering effort.

These impressive features plus the new multi-encoder interface which supports all standard encoder types plus an additional option slot make the IndraDrive Cs the ideal choice for highly specialized drive applications. Integrated safety technology together with IEC-compliant motion logic and industry-specific technology modules predestine the IndraDrive Cs for a very wide range of applications.



# IndraDrive Cs – universal, intelligent and cost-effective

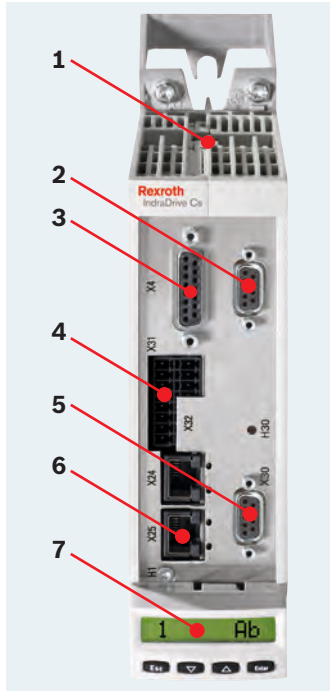

In addition to compact design and highly impressive performance specifications, the IndraDrive Cs offers a comprehensive portfolio of Ethernet-based communications interfaces.

The new communications interface supports a whole range of protocols. The IndraDrive Cs will run with a broad spectrum of Ethernet-based communications protocols without any hardware modifications.

IndraDrive Cs is compatible with the most common encoder types. This is a standard feature of the drives, and it means that you have complete freedom to choose the best motor/encoder system for your application.

<p><b>1 Integrated brake resistor</b></p>	<p><b>4 Interfaces</b> Digital inputs and outputs Analog input</p>	<p><b>6 Control communication</b> sercos III Multi-Ethernet</p>
<p><b>2 Safety option</b> Safe Torque Off Safe Motion</p>	<p><b>5 Option</b> Encoder interface PROFIBUS CANopen Encoder emulation</p>	<p><b>7 Operator panel</b> with programming module function</p>
<p><b>3 Multi-encoder interface</b></p>		



The simple step-by-step guide to ordering your multi-protocol-capable compact drive system – IndraDrive Cs:

**HCS01.1E-W0013-A-02-B-ET-EC-NN-NN-NN-FW**

**Maximum current**

E.g. 0013 = 13 A

**Protection category**

A = IP20

**Mains voltage**

02 = 3 x AC 110 to 230 V  
03 = 3 x AC 200 to 500 V

**Control unit/control communication**

E-S3 = ECONOMY with sercos III  
B-ET = BASIC UNIVERSAL with Multi-Ethernet (sercos III, PROFINET IO, EtherNet/IP, EtherCAT)  
A-CC = ADVANCED with sercos III master

**Safety technology**

L3 = Safe Torque Off  
S4 = Safe Motion <sup>1)</sup>  
NN = No safety technology  
L4 = Safe Torque Off with Safe Brake Control

**Option<sup>1)</sup>**

EC = Multi-encoder interface  
PB = PROFIBUS  
NN = Not equipped  
EM = Encoder emulation  
CN = CANopen  
ET = Multi-Ethernet <sup>2)</sup>

**Multi-encoder interface**

EC = IndraDyn motors, Hiperface®, 1 V<sub>pp</sub>, 5 V TTL, EnDat 2.1, Resolver

<sup>1)</sup> Not available with ECONOMY version

<sup>2)</sup> Only with ADVANCED version

Performance data	Mains voltage	Size	Continuous current	Maximum current	DC bus continuous power without/with mains choke
	V		A <sub>eff</sub>	A <sub>eff</sub>	
HCS01.1E-W0003-A-02	3 AC 110 to 230 V <sup>1)</sup>	1	1.4	3.3	0.15/-
HCS01.1E-W0006-A-02		1	2.4	6.0	0.25/-
HCS01.1E-W0009-A-02		1	3.0	9.0	0.46/-
HCS01.1E-W0013-A-02		1	4.4	13.0	0.80/-
HCS01.1E-W0018-A-02		2	7.6	18.0	1.80/-
HCS01.1E-W0005-A-03	3 AC 200 to 500 V	1	2.0	5.0	0.46/-
HCS01.1E-W0008-A-03		1	2.7	8.0	0.86/-
HCS01.1E-W0018-A-03		2	7.6	18.0	1.70/-
HCS01.1E-W0028-A-03		2	11.5	28.0	2.60/4.00
HCS01.1E-W0054-A-03		3	21.0	54.0	9.00/14.00

<sup>1)</sup> Single-phase power supply possible, derating with HCS01.1E-W0013 and -W0018

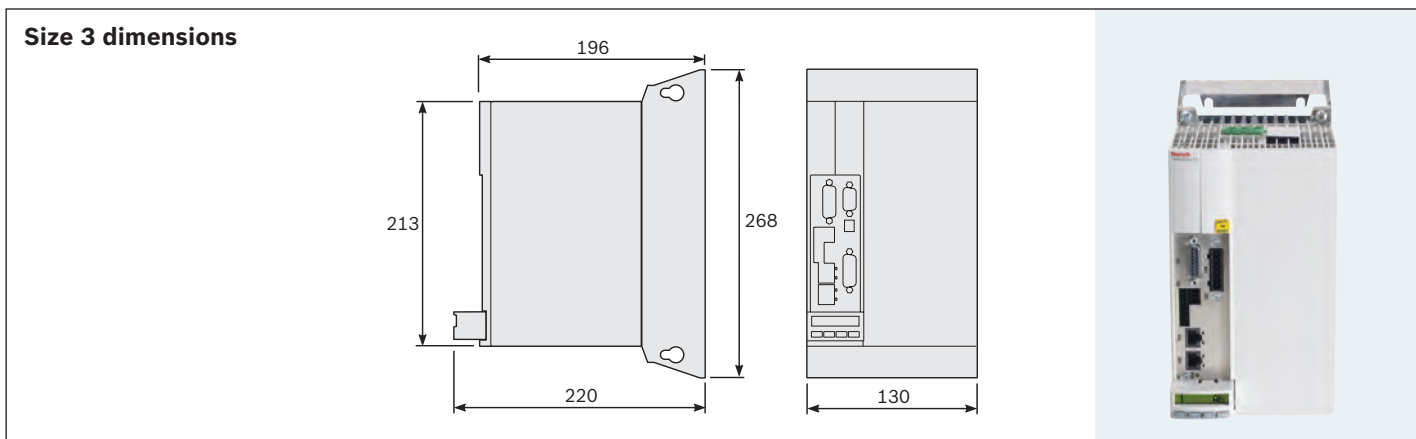
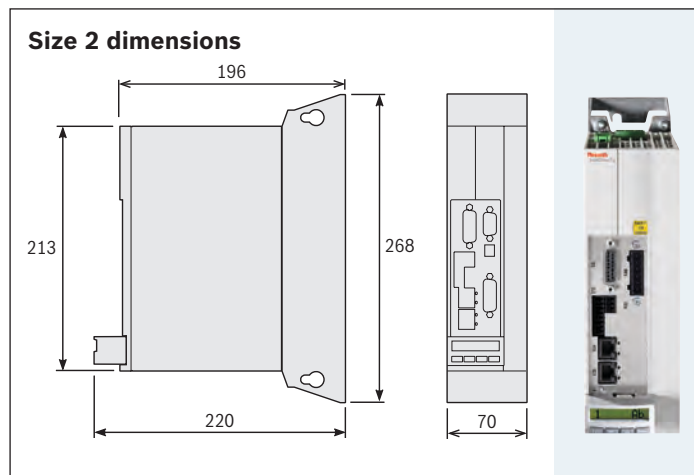
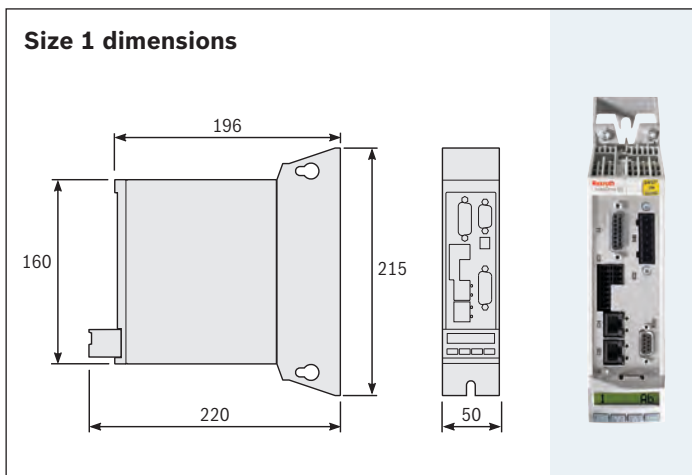

### Technical features

- ▶ 2 series for direct connection to 110 – 230 V AC or 200 – 500 V AC
- ▶ Suitable for motors with continuous outputs of 0.05 to 9 kW
- ▶ Complete range of scalable drives
- ▶ Compatible with the IndraDrive family
- ▶ Digital inputs/outputs and analog input on board
- ▶ Intelligent operating panel with programming module function, supports device swap without a PC
- ▶ IEC-compliant motion logic IndraMotion MLD (optional)
- ▶ Integrated Safe Torque Off or Safe Motion safety technology up to category 4 PLe according to ISO 13849-1 and SIL 3 according to IEC 62061 (optional)
- ▶ Integrated brake resistor; external brake resistor can be connected as an alternative

# IndraDrive Mi – Cabinet-free drive technology

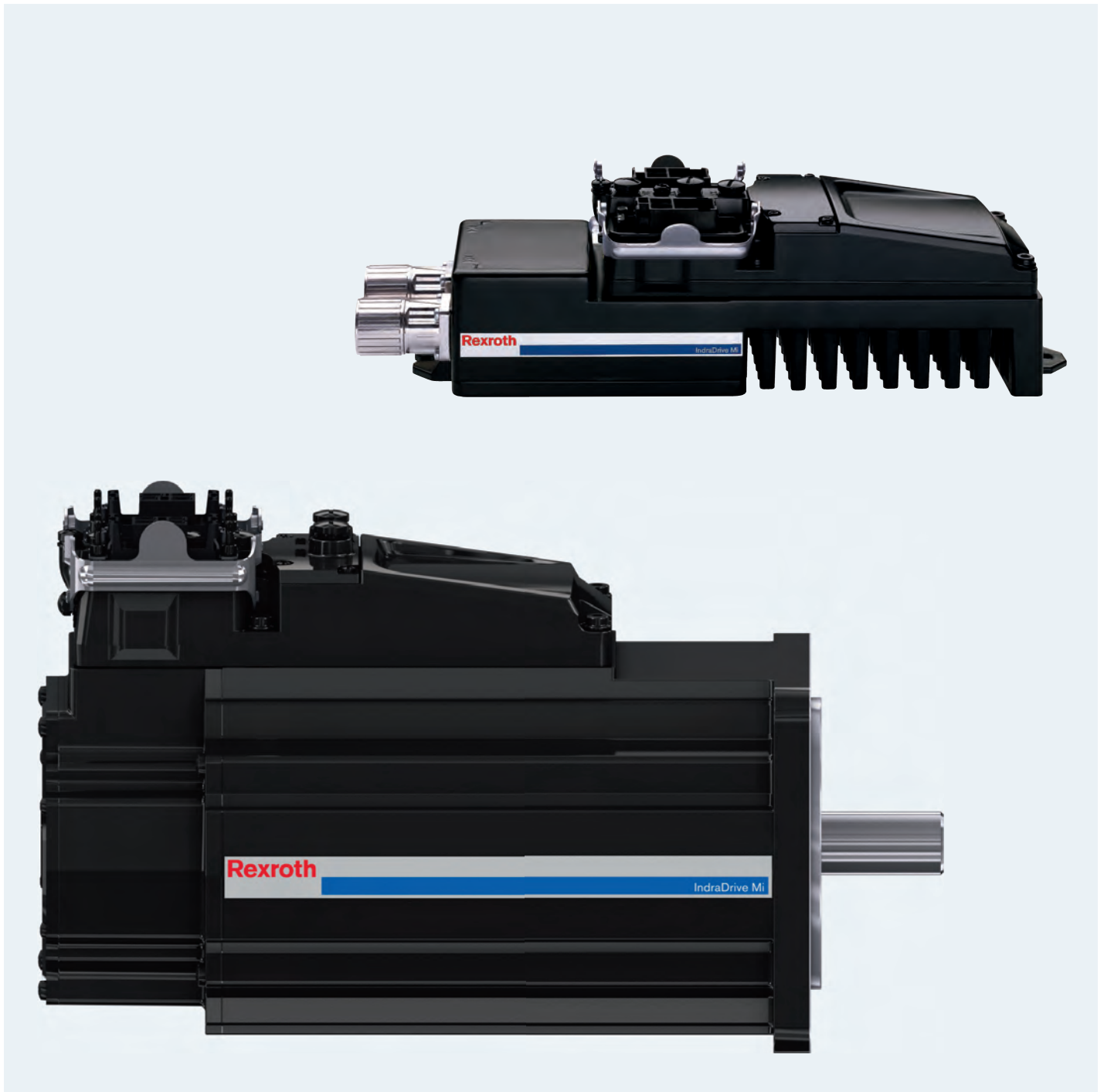

### Compact and economically efficient

- ▶ Control cabinet size reduced by up to 90%
- ▶ Up to 90% less wiring thanks to hybrid cable technology for power supply and communication
- ▶ Reduction of energy loss in the cabinet by up to 90%



### Motor-integrated servo drive KSM

With KSM, the motor-integrated servo drive series of IndraDrive Mi, Rexroth introduces another milestone in drive technology – electronic control system and servo motor combined in one ultra-compact unit.

This makes IndraDrive Mi the ideal solution for all applications where maximum flexibility and economic efficiency should come along with minimum space requirements.

In addition to its compact design, KSM combines the best characteristics of an IndraDrive and MSK servo motor – from the drive-integrated PLC according to IEC 61131-3 and safety technology up to protection category IP65.



### Motor-side servo drive KMS

The motor-side servo drive KMS, in protection category IP65, provides seamless integration of IndraDyn servo motors and 3rd party motors into a chain of IndraDrive Mi drives.



### Electronic control system KCU

The electronic control system KCU allows all required connections for a daisy chain of up to 20 IndraDrive Mi – this reduces the installation workload to a minimum.

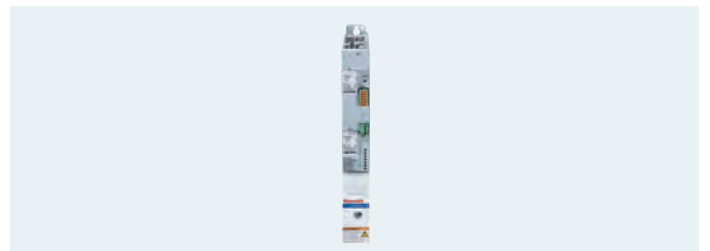

### Accessories

- ▶ Hybrid cable – for communication and power supply
- ▶ Terminal connector – for terminating the drive chain
- ▶ Interface cable – for connection to a PC
- ▶ I/O cable – for linking digital I/O signals
- ▶ Interface cable – for Multi-Ethernet output



# IndraDrive Mi – Motor-integrated servo drive KSM



The compact control electronics of the motor-integrated servo drive KSM uses the lateral surface of the servo motor as a cooling element.

This reduces the control cabinet size by up to 90% compared to classical servo drive solutions and by up to 30% compared to other integrated solutions.

Another advantage of IndraDrive Mi is the significantly reduced installation work – a single cable is sufficient for power supply and communication via Multi-Ethernet.

<b>1 Display</b> Diagnosis LED	<b>4 Interfaces</b> 4 digital inputs and outputs, two of which can be used as quick inputs for probes
<b>2 Safety technology</b>	<b>5 Multi-Ethernet output</b>
<b>3 Connector sockets</b> Hybrid cable	<b>6 Programming module</b>

The simple step-by-step guide to ordering your motor-integrated servo drive KSM:

**KSM02.1B-061C-35 N-M1-HP0-ET-NN-D7-NN-FW**

**Control unit version**

**B** = BASIC

**Basic motor**

- ▶ Overall size (e.g. "061")
- ▶ Overall length (e.g. "C")
- ▶ Winding (e.g. "35")

**Cooling system**

**N** = Natural convection

**Encoder**

- S1** = Single-turn encoder (Hiperface®), 128 signal periods
- M1** = Multi-turn encoder (Hiperface®), 128 signal periods with 4096 revolutions absolute
- S3** = Single-turn capacitive encoder (Hiperface®), 16 signal periods
- M3** = Multi-turn capacitive encoder (Hiperface®), 16 signal periods with 4096 revolutions absolute

**Electrical connection**

**H** = Connector, hybrid

**Other versions**

**TO** = Multi-Ethernet output

**NN** = No

**Supply voltage**

**D7** = DC 750 V

**Safety technology**

**NN** = No safety technology

**L3** = Safe Torque Off (STO)

**S3** = Safe Motion

**Control communication**

**ET** = Multi-Ethernet

**Holding brake**

**0** = Without holding brake

**2** = With electrically released holding brake (DC 24 V)

**Shaft**

**G** = Plain shaft with shaft sealing ring

**P** = Keyway conforming to DIN 6885-1 and shaft sealing ring



Distributed servo drive		Maximum speed <sup>1)</sup>	Conti-nuous torque at standstill 60K	Maxi-mum torque	Conti-nuous current at standstill	Maxi-mum current	Moment of inertia	Dimensions							Weight <sup>2)</sup>	
		$n_{Max}$	$M_{0,60}$	$M_{Max}$	$I_0$	$I_{Max}$	$J_R$	A	B	C	Ø D	Ø E	Ø F	Ø G	H	m
		rpm	Nm	Nm	A	A	kgm <sup>2</sup>	mm	mm	mm	mm	mm	mm	mm	mm	kg
KSM02.1B-041	C-42	5,500	2.2	9.4	1.5	6.8	0.00017	82	252	30	14	50	95	6.6	194	5.6/5.9
KSM02.1B-061	C-35	4,300	6	25	3.3	14.9	0.00087	115	271	40	19	95	130	9	219	9.6/10.1
	C-61	6,000	5.5	18	5.2	17.7	0.00087	115	271	40	19	95	130	9	219	9.6/10.1
KSM02.1B-071	C-24	3,400	10.5	35	4.6	17.7	0.00173	140	307	58	32	130	165	11	247	14.1/15.2
	C-35	4,700	10	28	6	17.7	0.00173	140	307	58	32	130	165	11	247	14.1/15.2
KSM02.1B-076	C-35	4,700	8.7	29	5.2	17.7	0.0043	140	290	50	24	110	165	11	247	14.6/15.7

All data relate to the basic version of the distributed servo drive with encoder S1 and without holding brake

<sup>1)</sup> At 750 V DC bus voltage; <sup>2)</sup> Values without/with holding brake

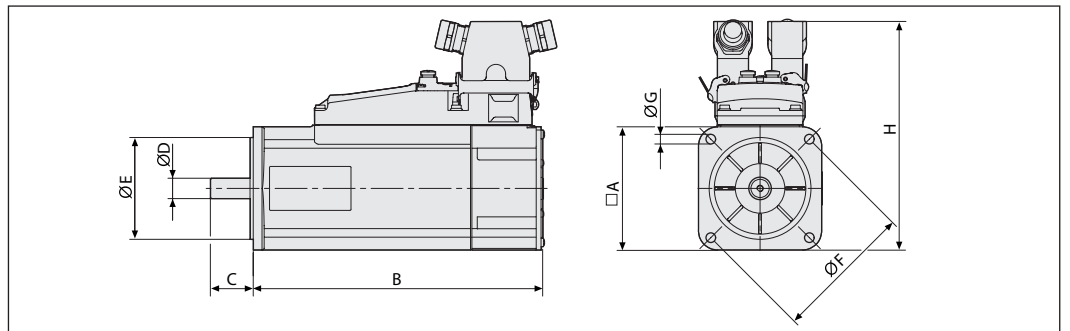
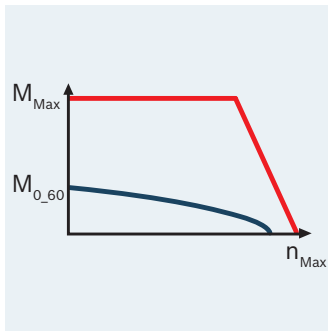

**All advantages at a glance**

- ▶ Multi-Ethernet communication for a variety of automation environments
- ▶ Control communication output to connect distributed peripherals
- ▶ SafeTorque Off (STO) function, including the easy creation of safety zones and SafeMotion
- ▶ Comprehensive firmware options (integrated motion logic, etc.)
- ▶ Various mechanical designs

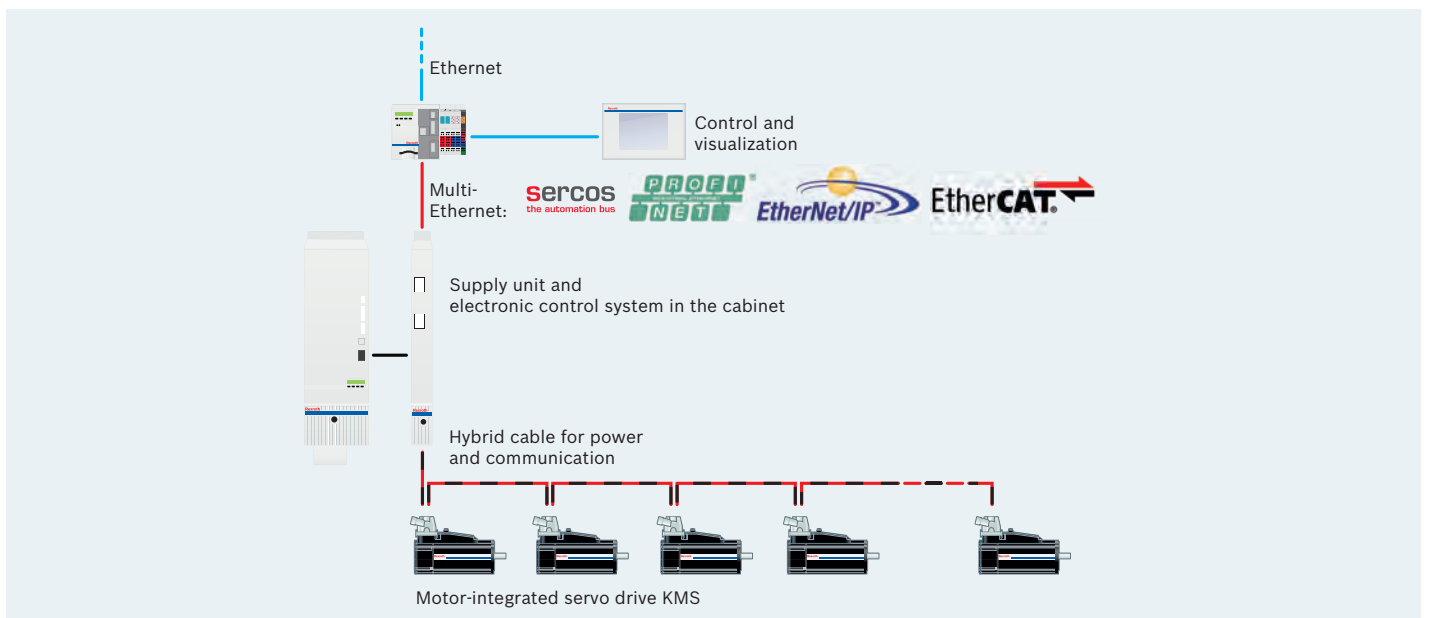

# IndraDrive Mi – Motor-side servo drive KMS

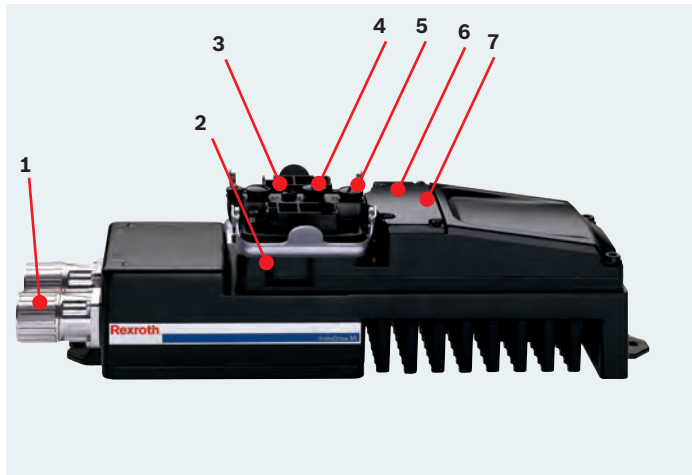

The motor-side servo drive KMS enables users to seamlessly integrate a wide range of motors into an IndraDrive Mi drive chain.

It is the solution of choice when:

- ▶ MSK030 servo motors, which due to their size are not suitable for IndraDrive Mi, need to be integrated into a chain of drives
- ▶ MSK servo motors need to be integrated because space constraints preclude the use of motor-integrated KSM servo motors
- ▶ Additional 3rd-party motors in open-loop mode or with Hiperface® encoders need to be attached

As is the case with KSM distributed servo drives, a hybrid communications/power cable is used to connect the drives.

<b>1 Motor interface</b> Encoder and power supply	<b>5 Interfaces</b> 4 digital inputs and outputs, two of which can be used as quick inputs for probes
<b>2 Display</b> Diagnosis LED	
<b>3 Safety technology</b>	<b>6 Multi-Ethernet output</b>
<b>4 Connector sockets</b> Hybrid cable	<b>7 Programming module</b>

The simple step-by-step guide to ordering your motor-side servo drive KMS:

## KMS02.1B-A018-P-D7-ET-ENH-NN-NN-FW

### Cooling system

**A** = Natural convection

### Maximum current

**018** = 18 A

### Protection category

**P** = IP65

### DC bus nominal voltage

**D7** = DC 750 V

### Other versions

**TO** = Multi-Ethernet output

**NN** = None

### Safety technology

**NN** = No safety technology

**L3** = Safe Torque Off (STO)

**S3** = Safe Motion

### Encoder interface

**ENH** = Hiperface®

**NNN** = Without encoder<sup>1)</sup>

### Control communication

**ET** = Multi-Ethernet

<sup>1)</sup> Without holding brake control

Motor-side servo drive	Continuous current		Maximum current		Dimensions				Weight
	$I_0$		$I_{Max}$		A	B	C	D	m
	A		A		mm	mm	mm	mm	kg
KMS02.1B	6		18		316	25	147	87	2.5

All data refer to the operation with 750 V DC bus voltage

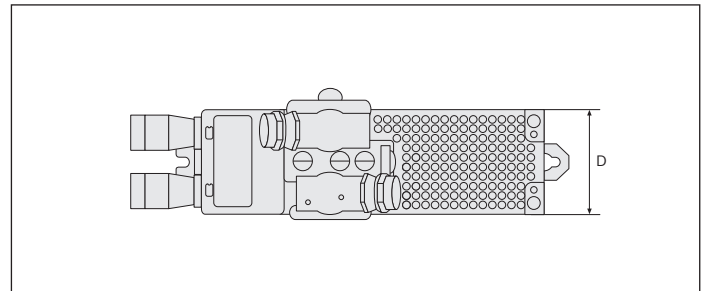
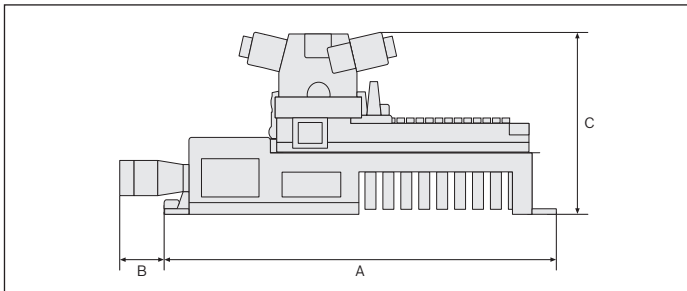

**All advantages at a glance**

- ▶ Multi-Ethernet communication for a variety of automation environments
- ▶ Control communication output to connect distributed peripherals
- ▶ Safe Torque Off (STO) function, including the easy creation of safety zones and Safe Motion
- ▶ Comprehensive firmware options (integrated motion logic, etc.)
- ▶ Integration of small servo or third-party motors (with or without encoders) Motors on KMS motor-side servo drives

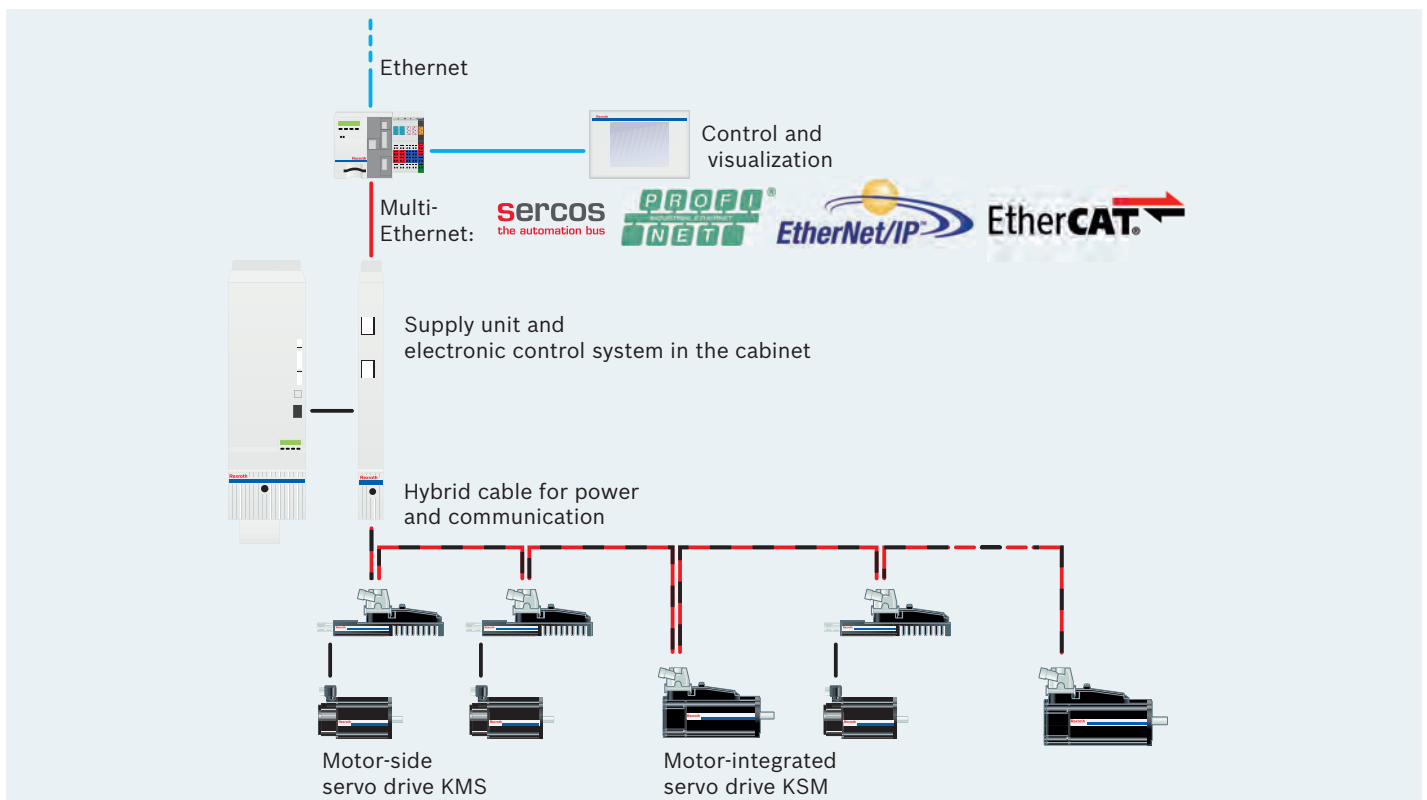

# IndraDrive Mi – electronic control system KCU

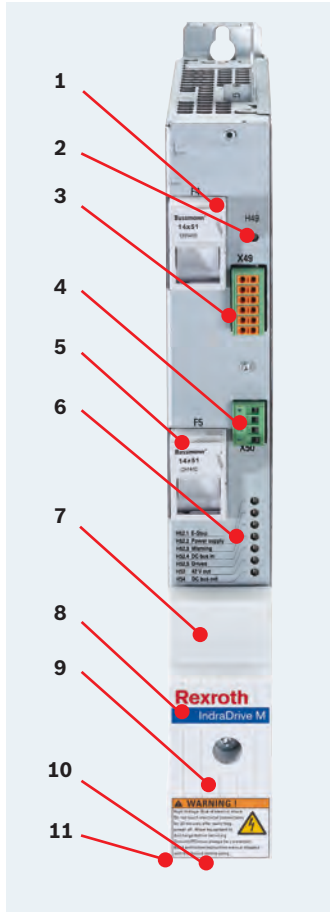

The compact electronic control system KCU allows all necessary connections to the IndraDrive Mi at a common coupling:

- ▶ Routing of the power supply from the DC bus of an IndraDrive converter or supply unit
- ▶ Supply of control voltage to the IndraDrive Mi
- ▶ Exchange of status and diagnostic messages between IndraDrive Mi and supply unit
- ▶ Protection of the DC bus connection with integrated fuses. Up to 20 IndraDrive Mi drives can be connected to a hybrid cable with a maximum length of 200 m.
- ▶ Multiple parallel drive chains possible

Up to 20 IndraDrive Mi units can be flexibly connected in series in one drive chain, with a max. cable length of 200 m – without any modifications to the cabinet.

If required, it is also possible to connect a number of KCU electronic control systems to a single supply unit in order to operate several IndraDrive Mi drive chains in parallel.

<b>1 Fuse</b> DC output L+	<b>5 Fuse</b> DC output L-	<b>9 DC input</b> DC bus
<b>2 Safety technology diagnosis display</b>	<b>6 Status and diagnosis display</b>	<b>10 Multi-Ethernet input</b>
<b>3 Safety technology</b>	<b>7 Input</b> Module bus	<b>11 Hybrid cable connection</b> Multi-Ethernet Control voltage DC bus voltage Status messages
<b>4 E-stop input</b>	<b>8 Input</b> Control voltage	

Electronic control system	Nominal voltage input	Nominal current input	Dimensions			Weight
	V	A	A mm	B mm	C mm	m kg
	KCU02.1N-ET-ET*-025-NN-N-NN-NW	DC 540 ... 750	25	352	50	252

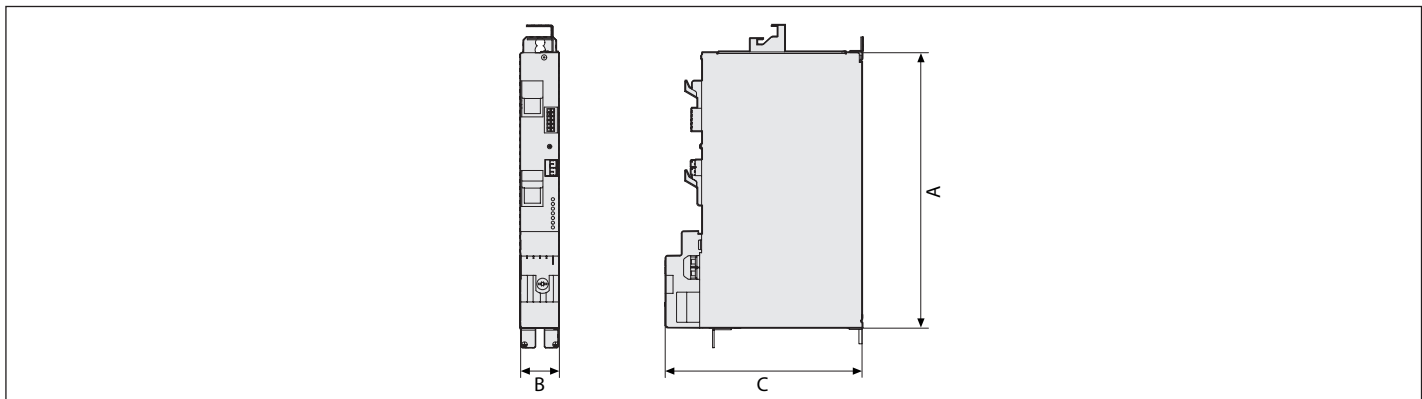

# IndraDrive Mi – accessories

## Hybrid cable and terminal connector

The significant reduction of installation work is one of the big advantages of the IndraDrive Mi – a single cable is sufficient for power supply and communication via Multi-Ethernet.

The hybrid cable RKH is supplied pre-assembled with plug-in connectors. Coded connectors ensure that the hybrid cable is connected with the correct polarity. From the wide range of connecting cables, select the suitable outgoing direction for your application.

Each cable with one or several IndraDrive Mi is terminated with a terminal connector RHS0014.



## Interface cable

For linking digital I/O signals to the IndraDrive Mi, use the pre-assembled cable RSK0010.

The cables RKB0033 (M12-M12) and RKB0044 (M12-RJ45) can be used to integrate additional Multi-Ethernet-capable components in the IndraDrive Mi chain using a Multi-Ethernet output.

The safety technology is connected at the start of a safety technology zone using the cable RKB0033. The RBS0023 plug is attached to all other participants.



# Rexroth IndraDrive – firmware

<b>BASIC</b> Single-axis and double-axis versions		<b>ADVANCED</b> Single-axis version	
Technology functions	Technology functions	Motion control technology functions	Motion control technology functions
<b>Motion logic<sup>1)</sup></b>		<b>Motion logic</b>	
<b>OPEN LOOP</b> main spindle	<b>BASIC main spindle</b>	<b>OPEN LOOP</b> main spindle	<b>ADVANCED main spindle</b>
<b>OPEN LOOP</b> synchronization	<b>BASIC</b> synchronization	<b>OPEN LOOP</b> synchronization	<b>ADVANCED</b> synchronization
	<b>BASIC</b> servo extension		<b>ADVANCED</b> servo extension
<b>Extension packages</b>		<b>Extension packages</b>	
<b>OPEN LOOP</b>	<b>CLOSED LOOP</b>	<b>OPEN LOOP</b>	<b>CLOSED LOOP</b>
<b>Basic package</b>		<b>Basic package</b>	

<sup>1)</sup> Not with double-axis version

The firmware can be tailored to your specific application in a number of flexible configurations:

- ▶ Basic OPEN LOOP package (frequency converter applications)
- ▶ Basic CLOSED LOOP package (servo and frequency converter applications)
- ▶ Extension packages (optional)
- ▶ Motion logic (IndraMotion MLD option)

The basic package is already sufficient to perform the majority of standard drive functions – from simple V/f control right through to positioning block mode. Various extension packages provide you with the options of electronic synchronization, additional servo functions or main spindle operation. The freely-programmable motion logic with integrated PLC conforming to IEC 61131-3 and ready-to-use technology functions enable simple execution of complex machine processes.

The simple step-by-step guide to ordering your IndraDrive firmware:

**FWA-INDRV\*-MPH-08VRS-D5-1-SNC-ML**

**Firmware IndraDrive**

**Firmware version**

- MPH**= ADVANCED
- MPB**= BASIC single-axis
- MPD**= BASIC double-axis

**Version**

Version 08, current release

**Languages**

German, English, French, Italian, Spanish

**Control**

- 0** = OPEN LOOP
- 1** = CLOSED LOOP

**Drive PLC**

**MA** = ADVANCED motion logic for complex technology functions

**ML** = With motion logic and technology functions

**TF** = Suitable for technology functions

**NN** = Without motion logic

**Extension package**

**SRV** = Servo extension

**SNC** = Electronic synchronization

**MSP** = Main spindle extension

**ALL** = All extensions

**NNN** = No extensions

### Customized functionality

- ▶ All standard functions already included
- ▶ Individual function extensions
- ▶ Industry-specific technology functions
- ▶ Integrated IEC-compliant motion logic

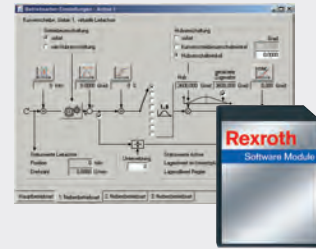

Basic packages	BASIC		ADVANCED	
	OPEN LOOP	CLOSED LOOP	OPEN LOOP	CLOSED LOOP
<b>Basic functions</b>				
Electronic type plate				
Automatic control circuit adjustment				
Setpoint generator for control optimization	•	•	•	•
Travel to fixed stop				
Adjustable error response				
Brake control				
Oscilloscope function				
<b>Basic functions OPEN LOOP</b>				
Motor control with V/f-curve, incl. slip compensation, I x R compensation and stall protection	•	•	•	•
Sensorless vector control				
Speed ramp generator				
Motorized potentiometer function				
<b>Basic functions CLOSED LOOP</b>				
Position, speed and torque control				
Drive-controlled referencing				
Drive-controlled positioning				
Interpolation inside drive				
Positioning block mode				
Position, speed and torque limit	-	•	-	•
Automatic commutation adjustment				
Path switching point with ON and OFF switching threshold				
Encoder emulation, incremental or absolute (SSI format)				
Automatic load detection				

<sup>1)</sup> Not with double-axis control units  
<sup>2)</sup> BASIC control units are restricted in terms of performance

Extension packages	BASIC		ADVANCED	
	OPEN LOOP	CLOSED LOOP	OPEN LOOP	CLOSED LOOP
<b>Servo extension</b>				
Parameter block changeover	• <sup>1)</sup>	•	•	•
Easy compensation of backlash on reversal	-	•	-	•
Axis error correction	-	-	-	•
Quadrant error correction	-	-	-	•
Frictional torque compensation	-	•	-	•
Probe with fast stop	-	1	-	2
Dynamic programmable limit switch	-	•	-	•
<b>Main spindle</b>				
Parameter block changeover	• <sup>1)</sup>	•	•	•
Spindle positioning mode	-	•	-	•
Drive-controlled gear changes	-	-	-	•
<b>Synchronization</b>				
Parameter block changeover	• <sup>1)</sup>	•	•	•
Speed synchronization	•	•	•	•
Angle synchronization	-	•	-	•
Measuring wheel mode	-	•	-	•
Real and virtual leading axis	•	•	•	•
Cam plate (tabular value)	-	•	-	•
Cam plate (analytical value)	-	-	-	•
Probe with time measurement	1	-	1	-
Probe with synchronization function	-	1	-	2
Dynamic programmable limit switch	-	•	-	•
<b>Motion logic</b>				
<b>IndraMotion MLD</b>				
Freely programmable in compliance with IEC 61131-3				
Programming system for IL, ST, FBD, LD, SFC and CFC				
4 freely configurable tasks (cyclic, free-running, event-controlled)	• <sup>2)</sup>	• <sup>2)</sup>	•	•
Libraries: system-specific, drive-specific, PLCopen				
Support of customer libraries				
Process-oriented technology packages				

# Rexroth IndraMotion MLD – integrated motion logic

## The world's first open drive

With IndraMotion MLD drive functions, motion control and processing logic merge to form a modern open automation platform for modular machine concepts. The drive-integrated motion logic reduces or even eliminates the need for higher-level control systems.

## Open standards

Standardized programming languages and the integrated engineering framework IndraWorks simplify project planning, programming, operation and diagnostics. At the same time you are directly investing your valuable know-how in the drive and thereby safeguarding your competitive edge.

Programming is in compliance with IEC 61131-3 in the following languages:

- ▶ Instruction list (IL)
- ▶ Structured text (ST)
- ▶ Functional block diagram (FBD)
- ▶ Ladder diagram (LD)
- ▶ Sequential function chart (SFC)
- ▶ Continuous function chart (CFC)

The availability of standardized modules in the PLCopen-compliant function library gives you access to a multitude of motion functions.

## Flexible programming

With user-definable programming you have the freedom and flexibility to configure your application to your requirements. Indeed, you have the latitude to combine innovative drive functions, extensive function libraries and process-oriented technology packages into one perfect automation solution.

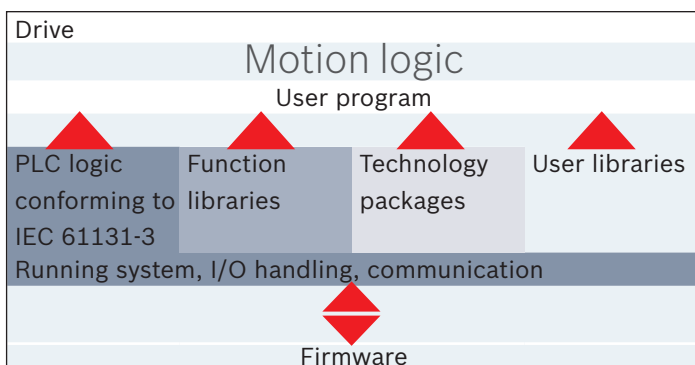

## Achieve your goals faster

Even large-scale and complex applications can be handled with ease with our ready-to-use function blocks and predefined technology packages. Combine them to form your own user program or simply use them as configurable functions.

Examples of items:

- ▶ PLCopen modules
- ▶ Programmable limit switch
- ▶ Print-mark control
- ▶ Register control
- ▶ Tension control
- ▶ Loop control
- ▶ Winder
- ▶ Demand processing
- ▶ Extended drive functions:
  - Variable retraction motion
  - Adaptive feedrate control
  - Analog force control and much more

Selected IndraMotion MLD function blocks and function libraries are available on DVD together with IndraWorks MLD, the simple, intuitive engineering tool for IndraDrive.

- ▶ Order code:  
SWA-IWORK-MLD-xxVRS-D0-DVD\*\*-COPY

## Innovative modules for any application

- ▶ **Function library**: Collection of function blocks conforming to IEC or PLCopen
- ▶ **User library**: Collection of function blocks developed by the user
- ▶ **Technology packages**: Process-oriented function blocks, e.g. tension control
- ▶ **User program**: Application-specific combination of different function blocks and technology packages



## Drive and control system seamlessly coordinated

- ▶ Highly-economic solution for single-axis and multi-axis applications without additional hardware
- ▶ Minimized engineering thanks to IEC- and PLCopen-compliant project planning
- ▶ Predefined technology packages for faster implementation



### Single-axis solution

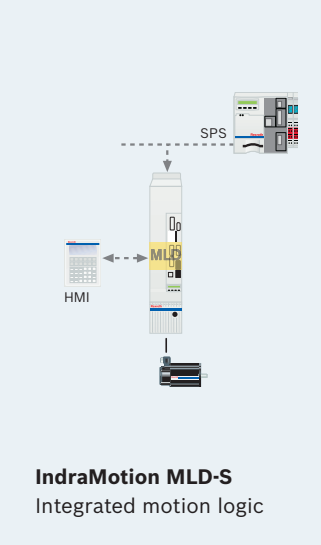

### Multi-axis solution

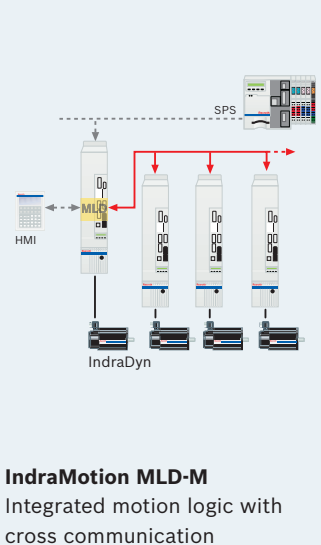

IndraMotion MLD	MLD-S BASIC	MLD-S ADVANCED	MLD-M ADVANCED
Number of axes	1	1	up to 10
Hardware requirement (master)	BASIC control unit CSB	ADVANCED control unit CSH	ADVANCED control unit CSH with option CCD
Firmware option	TF	ML/MA	ML/MA
<b>Performance</b>			
Processing time	Depends on the utilization of the BASIC drive		100 µs per 1,000 instructions in IL using bit and word processing
<b>Tasks</b>			
Number of tasks			4
Types of tasks	Cyclic, free-running, event-controlled		
Cycle time	ms	2	1
<b>Program memory</b>			
From firmware 04VRS	kB	Approx. 350	
From firmware 06VRS with option CCD	kB	–	4,000
<b>Retain data memory</b>			
On control unit	byte	248	248
With option MD1, MD2 or CCD	kB	–	32
<b>Programming</b>			
Programming system	Rexroth IndraWorks MLD		
Programming languages	Instruction list (IL), Structured text (ST), Functional block diagram (FBD), Ladder diagram (LD), Sequential function chart (SFC), Continuous function chart (CFC)		
Program debug functions	Breakpoint, single-step, single cycle, write/force, monitoring, sampling trace, simulation, online change		
Libraries supplied	System-specific, drive-specific and PLCopen		
<b>Control communication</b>			
Interfaces	sercos II, sercos III, PROFIBUS, Multi-Ethernet, DeviceNet, CANopen, parallel interface, analog interface, analog/digital for OPEN LOOP mode, IndraMotion MLD		
<b>Digital inputs and outputs</b>			
Inputs	5 <sup>1)</sup>	7	Depends on the number and type of control units and options used
Inputs/outputs (user-defined settings)	3 <sup>1)</sup>	4	
Option MD1	–	12 I/8 O	
Option MD2	–	16 I/16 O	
Parallel interface	16 I/16 O	16 I/16 O	
<b>Analog inputs and outputs</b>			
On control unit	–	1 I/2 O	Depends on the number and type of control units and options used
With option MA1	2 I/2 O	2 I/2 O	

<sup>1)</sup> Applies to control unit CSB01.1C

# Safety on Board – integrated safety technology

Whether for machine tools, printing and packaging or mounting, handling and robotics applications – protecting people from uncontrolled machine movements is top priority.

## Clear guidelines issued by the EU

All machine manufacturers are obliged to carry out a hazard evaluation and risk analysis prior to construction. This is stipulated in the European Machinery Directive 2006/42/EC. Moreover, any potential hazards detected must be eliminated step by step. Safety should be integrated in the machinery and meet current standards in technology.

## How safe can you get?

IndraDrive is redefining current standards in technology because IndraDrive integrates the safety directly in the drive, resulting in ultra-short response times. IndraDrive therefore demonstrates the current capacities and requirements of safety technology – IndraDrive is faster because the movement is monitored directly where it is generated. This is the critical advantage, especially when it comes to monitoring direct drives or other high-dynamic drives, for example.

## Quickest response times with highest drive dynamics

With the new IndraDrive generation from Rexroth, a variety of safety functions are available right inside the drive – without any detours through the control. This increases reliability, saves on additional monitoring components and reduces installation cost and effort.

It is all made possible by redundant software and hardware components in the drive. The non-contacting monitoring of all set limit values enables very short response times of less than 2 ms. As soon as an error is detected, all the drives are automatically stopped depending on the stop category selected (0, 1 or 2).

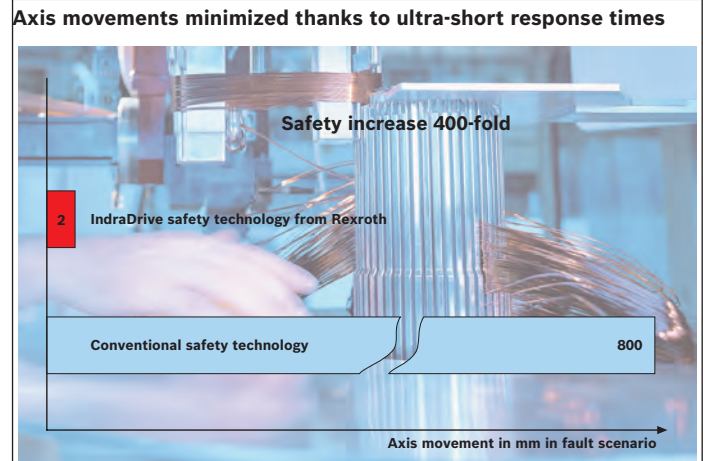

Before a user in the protected area reacts to an error with an acknowledgement linked to contacts, a linear axis with a ball screw has already traveled 100 to 200 mm, linear motors have already traveled 400 to 800 mm. IndraDrive safety technology finds the error within 2 ms and the axis moves only 2 mm.

## Safety functions inside the drive effectively protect people and machines

- ▶ High reliability due to certified integrated safety functions
- ▶ Extremely fast response times (< 2 ms) for fault detection by internal monitors
- ▶ No need for additional measuring systems or sensors
- ▶ Online dynamic sampling of the inputs and shutoff paths while work is in progress
- ▶ PROFIsafe interface with reduced configuration and installation effort and safe, distributed I/Os
- ▶ Reduced certification effort and short series start-up times

**SAFETY  
ON  
BOARD**

## Intelligent and safe

- ▶ Safety category 3, PL d, SIL 2
- ▶ Extensive safety functions
- ▶ Minimum response times
- ▶ Independent of the control system
- ▶ Straightforward integration in the machine

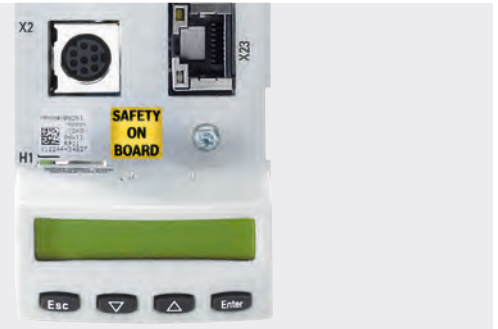

	<p><b>Safe Torque Off (STO)</b> Stop category 0 in accordance with ICE 60204-1: Safe drive torque cut off</p>		<p><b>Safe Maximum Speed (SMS)</b> The maximum speed is safely monitored irrespective of the mode of operation</p>
	<p><b>Safe Stop 1 (SS1)</b> Stop category 1 in accordance with ICE 60204-1: Safely monitored stop, control or drive controlled with safe drive torque cut off</p>		<p><b>Safe Braking and Holding System (SBS)</b> The safe braking and holding system controls and monitors two independent brakes</p>
	<p><b>Safe Stop 2, Safe Operating Stop (SS2, SOS)</b> Stop category 2 in accordance with ICE 60204-1: Safely monitored stop with safely monitored standstill at controlled torque</p>		<p><b>Safe Door Locking (SDL)</b> When all the drives in one protection zone are in safe status, the safety door lock is released</p>
	<p><b>Safely Limited Speed (SLS)</b> If enable signal is given, a safely limited speed is monitored in special operating mode</p>		<p><b>Safely Limited Increment (SLI)</b> If enable signal is given, a safely limited increment is monitored in special operating mode</p>
	<p><b>Safe Direction (SDI)</b> A safe direction (clockwise, counterclockwise) is also monitored in addition to safe motion</p>		<p><b>Safely Monitored Deceleration (SMD)</b> Safely monitored deceleration ramp when stopping with predetermining characteristics</p>
	<p><b>Safely Monitored Position (SMP)</b> A safely limited position range is also monitored in addition to safe motion</p>		<p><b>Safely Limited Position (SLP)</b> Monitoring of safe software limit switches</p>
	<p><b>Safe Inputs/Outputs (SIO)</b> Dual-channel safety peripherals can be connected to the drive and made available to the controller via the safety bus</p>		<p><b>Safe Communication (SCO)</b> Selection/deselection of safety functions and transfer of process data (e.g. actual position values) via safety bus</p>

All safety functions are certified as compliant with the standards EN ISO 13849-1:2006, EN 61800-5-2:2007, IEC 61508:1998-2000, EN 62061, ISO 13849-1:1999 EN 954-1:1996, EN ISO 13849-2:2003, EN 60204-1:1997, EN 50178-1:1997, EN 61800-3:2004, UL 508C R7.03, C22.2 No. 0.8-M86 (R2003), CAN/CSA C22.2 No. 14-95, NFPA 79:2007 ER1 through TÜV Rheinland and TÜV Rheinland North America Inc.

# Safety on Board – be on the safe side

## Safe Torque Off (STO)

The STO option is the most cost-effective solution for preventing the drive from restarting unintentionally. The power supply is cut off electronically on two channels. The STO option is activated via two redundant 24 V signals. This function can be selected with all control units except BASIC OPEN LOOP.

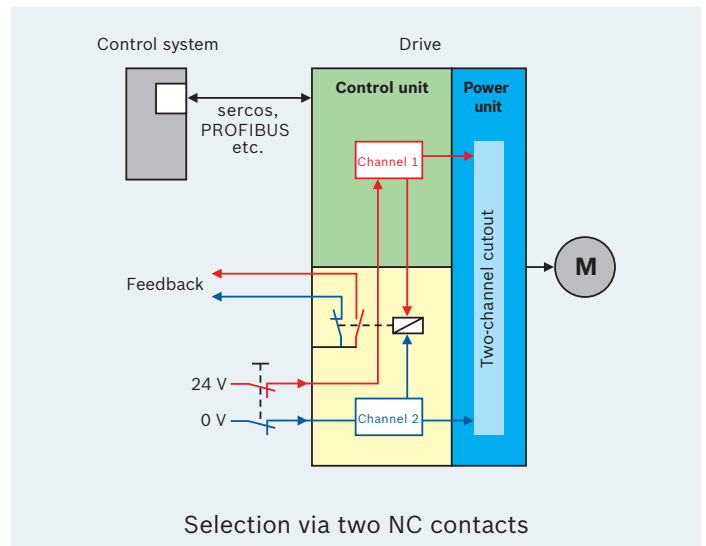
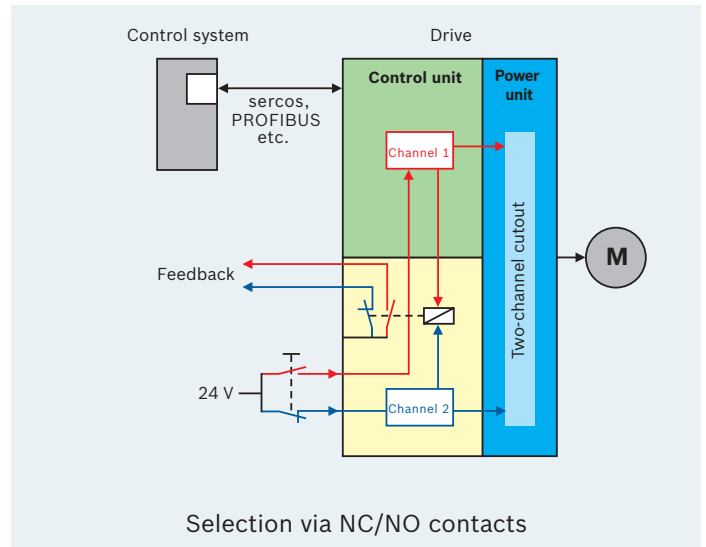

**Safe Motion**

The ADVANCED and BASIC UNIVERSAL double-axis control units offer you all the available safety functions – including safe motion and safe absolute position.

This safety is guaranteed by two redundant, diverse processor systems which carry out all the relevant calculations separately and monitor each other. The two-channel selection of the required safety function can be executed differently.

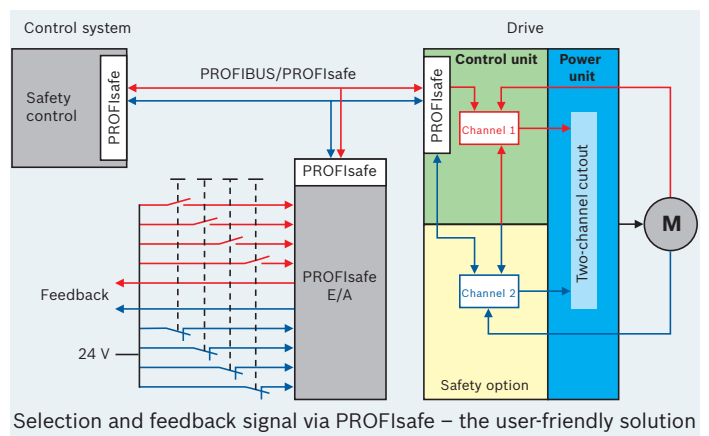
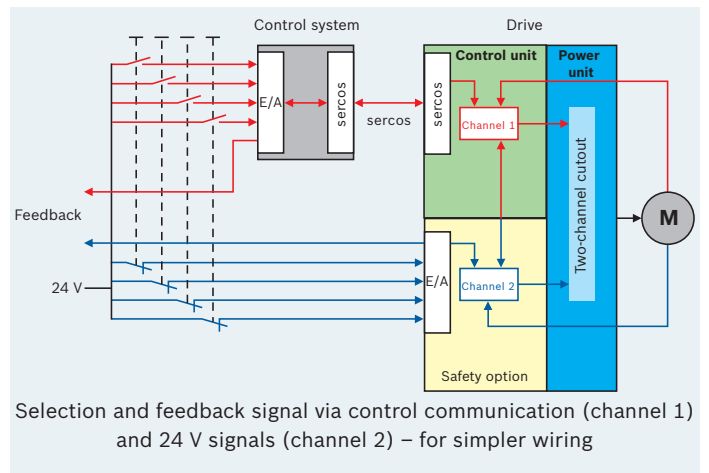
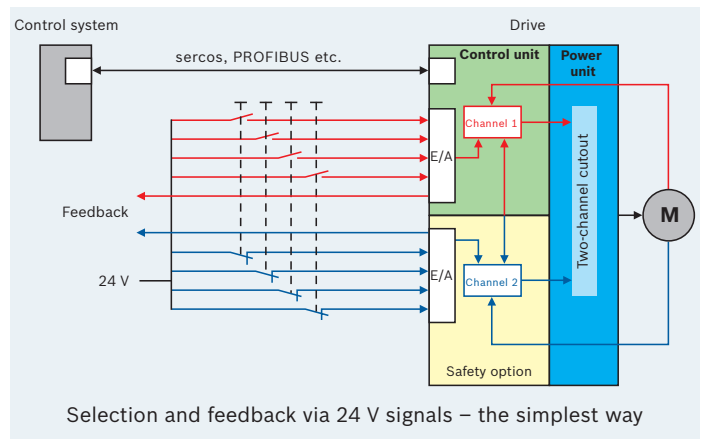

# Rexroth IndraWorks – one tool for all engineering tasks

Simple and user-friendly, Rexroth IndraWorks is the ideal engineering environment for all Rexroth electrical control and drive systems. This engineering framework brings together in one integrated interface all the tools required for:

- ▶ Configuration
- ▶ Programming
- ▶ Parameterization
- ▶ Operation
- ▶ Visualization
- ▶ Diagnostics

## Advantages

- ▶ Integrated software framework for all engineering tasks
- ▶ Application-oriented tools
- ▶ Intelligent user guidance
- ▶ User-friendly, menu-driven operation
- ▶ Standardized programming according to IEC 61131-3
- ▶ PLCopen-compliant module library
- ▶ Open-architecture through integrated FDT/DTM technology
- ▶ Cutting-edge Microsoft .NET technology

IndraWorks for IndraDrive is available on DVD:

- ▶ IndraWorks D – for drive engineering  
SWA-IWORKS-D\*\*-xxVRS-D0-DVD\*\*-COPY
- ▶ IndraWorks MLD – also includes support for IndraMotion MLD  
SWA-IWORKS-MLD-xxVRS-D0-DVD\*\*-COPY

You receive a simple, connection-based service tool along with IndraWorks D and MLD:

- ▶ IndraWorks Ds – for service and commissioning of single drives (part of IndraWorks D and IndraWorks MLD, available on the Internet or as a separate DVD)  
SWA-IWORKS-DS\*-xxVRS-D0-DVD\*\*-COPY

IndraWorks D and IndraWorks MLD can be combined with the CamBuilder cam editor:

- ▶ CamBuilder SWS-IWORKS-CAM-xxVRS-D0

Rexroth IndraWorks – the integrated engineering framework for project planning, programming, parameterization, operation and monitoring

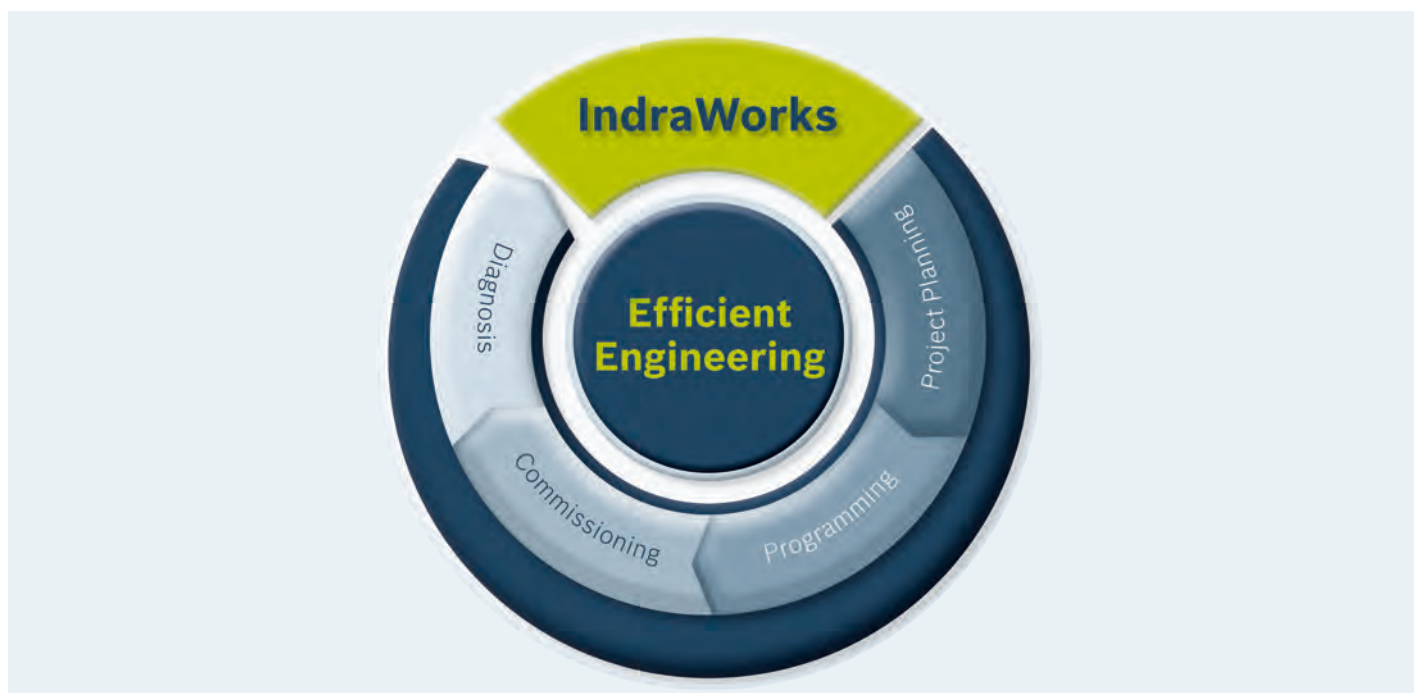

## IndraWorks – the universal engineering framework

- ▶ One tool for all automation tasks
- ▶ Guided start-up for rapid achievement of results
- ▶ Offline configuration of projects
- ▶ User-friendly programming environment



### Start-up wizard

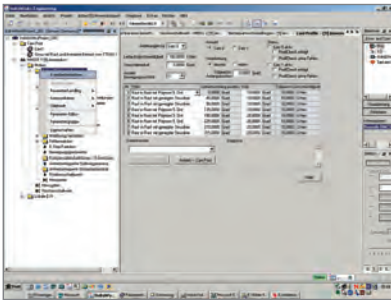

IndraWorks interactively guides you through all the steps of the startup process and only requires you to input the relevant data. All values to be input are directly related to the mechanics of the machine. This simplifies the input of data, along with allowing you to freely select measurement units.

You individually assemble the required sequence of movements from a large selection of positioning modes presented in graphic form. Once compiled, the set of parameters is saved in a file and can be easily transmitted to other machines via fieldbus or the RS232 serial interface.

### Offline mode

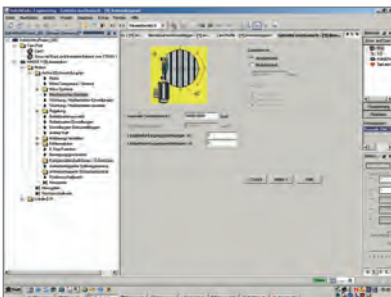

The machine-related modes of operation and the corresponding parameters can be set in advance offline and later transferred to the machine.

### Programming

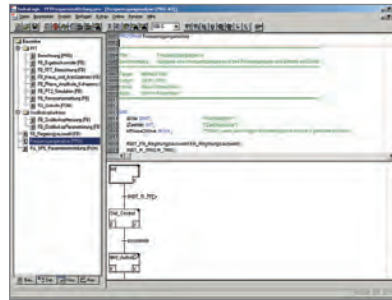

All functionality and programming modes according to IEC 61131-3 are available for the drive-integrated PLC.

With PLCopen function blocks, you can quickly and transparently integrate drive functionality into your PLC program.

Integrated technology functions  
The configurable motion logic-based technology functions allow you to perform the full range of different process-oriented tasks – and require no programming skills.

### Four-channel oscilloscope

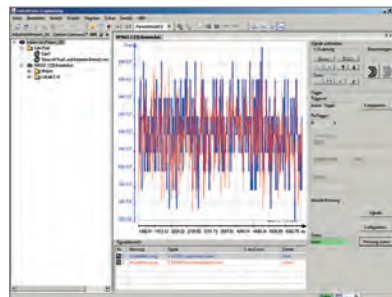

The integrated four-channel oscilloscope is available to assist with drive optimization, troubleshooting and preventive maintenance. For documentation purposes all the measurements and the related settings can be printed out or saved to a file.

### Auto-tuning

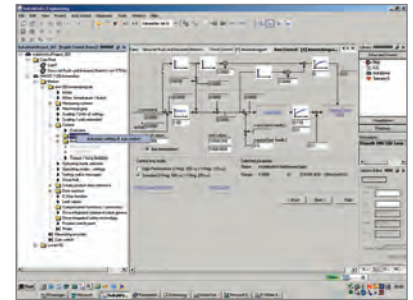

Parameters for all internal control functions are automatically set when IndraDyn motors are connected.

This setting is ideal for the majority of applications, requiring no further adjustment. Where requirements are more complex, the auto-tuning function is available to assist with adjusting the control settings to your machine.

### CamBuilder (optional)

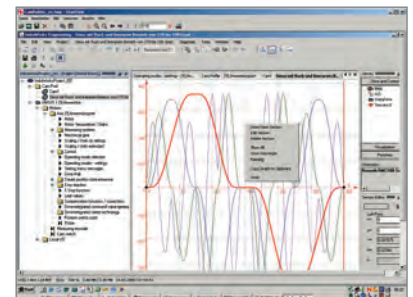

Rexroth CamBuilder is a graphics-based software tool for the convenient creation of electronic cams. With a few inputs, you can implement various applications easily and quickly. The established cams are directly transferable to Rexroth drives and controls.

# Rexroth IndraSize – rapid and safe sizing

IndraSize – the user-friendly program for drive sizing – is the quickest way to find the optimum drive for your machine. Regardless of whether you are using a conventional servo axis or direct drive, IndraSize allows you to define the ideal motor/drive combination in a few steps.

## Mechanics

IndraSize is compatible with all standard drive mechanisms such as:

- ▶ Ball screw with rotating screw
- ▶ Ball screw with rotating nut
- ▶ Rack and pinion
- ▶ Belt and pulley
- ▶ Linear direct drive
- ▶ Rotary drive
- ▶ Roller
- ▶ Rotary knife
- ▶ Winder/unwinder
- ▶ Roll feed

With the aid of graphics you simply simulate your machine kinematics, combining the motor and the selected mechanical parts with the various transfer units:

- ▶ Coupling
- ▶ Belt drive
- ▶ Gears

Any number of these can be combined in any order.

## Motion profile

With IndraSize you can freely compile a full motion profile from individual sequences of movements. If applicable, you may use higher-order equations of motion as e.g. polynomials or sinoids. Alternatively, import pre-assembled cams generated with the CamBuilder.









Moreover, IndraSize allows you to define typical applications very simply by inputting parameters. Applications can be configured in next to no time, such as:

- ▶ Roll feeds
- ▶ Flying cutoff
- ▶ Winders
- ▶ Cross cutters

## Download

IndraSize can be downloaded from the Internet at: [www.boschrexroth.com/indrasize](http://www.boschrexroth.com/indrasize)

## Mechanical system

	Ball screw with rotating screw		Ball screw with rotating nut
	Belt and pulley		Rack and pinion
	Linear direct drive		Rotary drive
	Rollers		

and much more



# Five steps to your drive solution

Regardless of whether you want to tackle a simple or complex drive task – whatever the case, IndraSize will lead you confidently through just five steps to success. Let the menu take you through the individual program steps from

selecting the mechanical system and associated motion profile right through to the point where you are presented with the optimum motor/drive combination together with a table or curve showing its performance data.

## Step 1:

Select mechanical system and motion profile

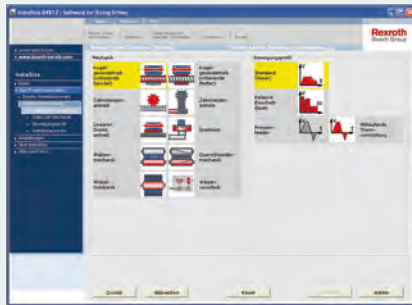

## Step 2:

Input mechanical and link element data



## Step 3:

Define the motion cycle



## Step 4:

Select the drive from the filtered list generated

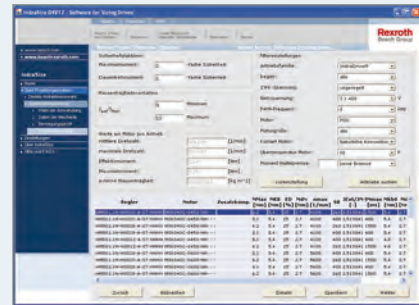

## Step 5:

Check and save drive details

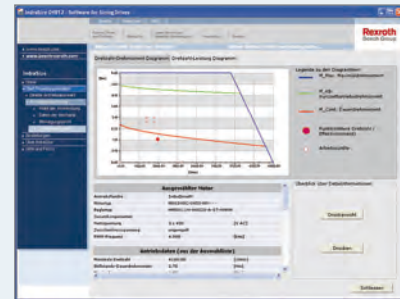

# Rexroth IndraDyn – motors and gearboxes



## A powerful family

- ▶ Extensive range including robust housed and high-speed motors
- ▶ Coverage of entire power range
- ▶ High-precision encoder systems
- ▶ Highly-dynamic synchronous linear motors
- ▶ Special hazardous duty designs conf. to ATEX or UL/CSA



### IndraDyn S

- ▶ Synchronous servo motors MSK with maximum torque of 631 Nm
- ▶ Synchronous servo motors MKE with explosion-proof enclosure for potentially explosive atmospheres up to 187 Nm
- ▶ Ultra-compact synchronous servo motors MSM rated at up to 7.1 Nm can be connected to the IndraDrive Cs



### IndraDyn A

- ▶ Air-cooled asynchronous servo motors MAD with power ratings up to 93 kW
- ▶ Liquid-cooled asynchronous servo motors MAF with power ratings up to 120 kW



### IndraDyn L

- ▶ Synchronous ironcore linear motors MLF for feeding forces of up to 21,500 N
- ▶ Synchronous ironless linear motors MCL with maximum speeds of up to 1,400 m/min



### IndraDyn T

- ▶ Synchronous torque motors MBT with torque ratings up to 13,800 Nm and speeds of up to 4,000 rpm



### IndraDyn H

- ▶ Synchronous high-speed motors MBS for speeds of up to 22,500 rpm and maximum torques of up to 4,500 Nm



### 1 MB

- ▶ Asynchronous high-speed motors for speeds of up to 20,000 rpm and rated torques of up to 875 Nm



### Servo gearboxes

- ▶ Standard planetary gearboxes GTE
- ▶ High-precision planetary gearboxes GTM



### Standard and geared motors

- ▶ Wide range of motors made by well-known manufacturers for combining with IndraDrive



# IndraDyn S – MSK synchronous servo motors

The particularly outstanding features of the MSK range of motors are its wide power spectrum and narrow size increments. The high torque density of these synchronous servo motors allows a particularly compact design with maximum torques of up to 631 Nm.

Depending on the required accuracy, you can choose between encoder systems with low, medium, or high resolution. All encoder versions are available in a single-turn and multi-turn configuration.

With numerous additional options, the MSK motors can be upgraded and tailored exactly to the desired requirement. The MSK series is thus also ideal for applications beyond the typical standard applications of servo motors.

The combination with IndraDrive control units results in high-performance drive systems with flexible configuration that offer innovative solutions for new drive applications.

The wide performance range of the MSK series of motors is supplemented with a multitude of functional options.



In addition to the different encoder systems, there is a wide choice of further options such as a shaft keyway, holding brake, and increased runout. For applications with high levels of continuous power, blower units for axial and radial mounting are available.

As with the MSK motors themselves, the blower motors also feature protection category IP65 as standard and are equipped with an integrated temperature sensor. This not only increases the reliability of the motors. The certified intrinsic safety of the blowers (“Thermally-Protected F” as per UL) also eliminates the need for an external motor circuit breaker. Liquid cooling is available for selected sizes for very high power applications.

## Example MSK071

MSK071  
Convection

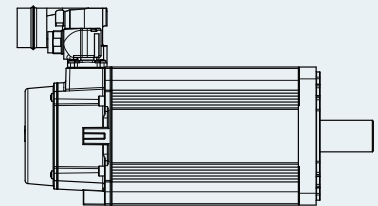

MSK071  
With blower

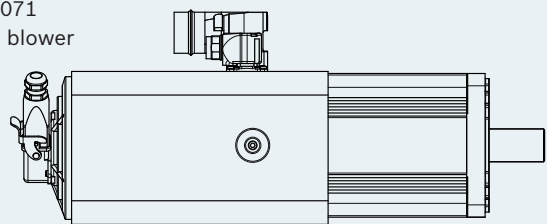

MSK071  
Liquid cooling  
system

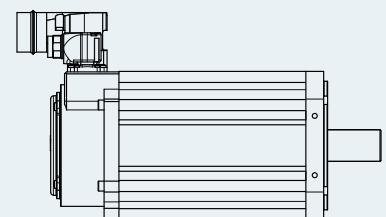

## Compact and powerful

- ▶ Maximum torques up to 631 Nm
- ▶ Maximum speeds up to 9,000 rpm
- ▶ Encoder systems for a wide and diverse range of applications
- ▶ High protection category IP65
- ▶ Choice of cooling systems

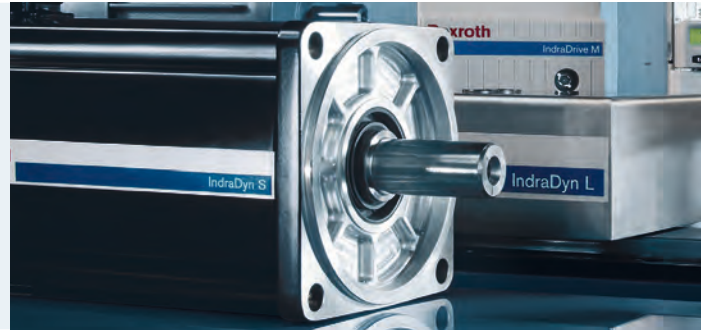

The simple step-by-step guide to ordering your MSK servo motor:

### MSK 060C-0600-NN-S1-U G0-NN NN

#### Motor

- ▶ Overall size (e.g. "060")
- ▶ Overall length (e.g. "C")
- ▶ Winding (e.g. "0600")

#### Cooling system

- NN** = Natural convection  
Blower can be fitted optionally from size 060
- FN<sup>1)</sup>** = Integrated liquid cooling system
- SA** = Integrated blower (only MSK133)

#### Encoder

- S1** = Single-turn encoder (Hiperface®), 128 signal periods
- M1** = Multi-turn encoder (Hiperface®), 128 signal periods with 4,096 revolutions absolute
- S2<sup>2)</sup>** = Single-turn encoder (EnDat), 2,048 signal periods
- M2<sup>2)</sup>** = Multi-turn encoder (EnDat) 2,048 signal periods with 4,096 revolutions absolute
- S3** = Single-turn encoder (Hiperface®), 16 signal periods
- M3** = Multi-turn encoder (Hiperface®), 16 signal periods with 4,096 revolutions absolute

#### Shaft

- G** = Plain shaft with shaft sealing ring
- P** = Keyway conforming to DIN 6885-1 and shaft sealing ring

#### Other versions

- N** = Standard
- S<sup>1)</sup>** = Ex-protected version conforming to Equipment Group II, Category 3, G and D

#### Shaft runout

- N** = Standard, in conjunction with S1/M1 or S3/M3 encoder only
- R** = Reduced, linear movement conforming to DIN 42955, in conjunction with S2 or M2 encoder only

#### Holding brake<sup>1)</sup>

- 0** = Without holding brake
- 1** = With electr. released holding brake
- 2** = With heavy-duty holding brake
- 3** = With extra-heavy-duty holding brake

<sup>1)</sup> Only for certain sizes  
See the product documentation for an exact breakdown

<sup>2)</sup> For sizes 040 to 131

## Example curve

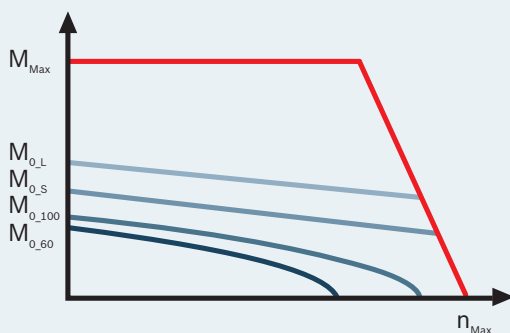

Continuous torque at standstill  $M_0$

$M_{0,L}$  = Liquid-cooled

$M_{0,S}$  = Surface-ventilated

$M_{0,100}$  = 100K, non-insulated design

$M_{0,60}$  = 60K, insulated design

See the following pages for an overview of the motor data

# IndraDyn S – technical data

Type	Maximum speed <sup>1)</sup>	Continuous torque at standstill				Maximum torque	Continuous current at standstill				Maximum current
	$n_{Max}$	60K	100K	Blower	L cooling	$M_{Max}$	60K	100K	Blower	L cooling	$I_{Max}$
	rpm	$M_{0,60}$	$M_{0,100}$	$M_{0,S}^{2)}$	$M_{0,L}^{2)}$	Nm	$I_{0,60}$	$I_{0,100}$	$I_{0,S}^{2)}$	$I_{0,L}^{2)}$	A
MSK030B-0900-NN	9.000	0,4	0,45	–	–	1,8	1,5	1,7	–	–	6,8
MSK030C-0900-NN	9.000	0,8	0,9	–	–	4	1,5	1,7	–	–	6,8
MSK040B-0450-NN	6.000	1,7	1,9	–	–	5,1	1,5	1,7	–	–	6
MSK040B-0600-NN	7.500	1,7	1,9	–	–	5,1	2	2,2	–	–	8
MSK040C-0450-NN	6.000	2,7	3,1	–	–	8,1	2,4	3,1	–	–	9,6
MSK040C-0600-NN	7.500	2,7	3,1	–	–	8,1	3,1	4,7	–	–	12,4
MSK043C-0600-NN	7.500	2,7	3,1	–	–	12,5	3,6	4,3	–	–	18,5
MSK050B-0300-NN	4.300	3	3,4	–	–	9	1,8	2	–	–	7,2
MSK050B-0450-NN	6.000	3	3,4	–	–	9	2,8	3,2	–	–	11,2
MSK050B-0600-NN	6.000	3	3,4	–	–	9	3,7	4,2	–	–	14,8
MSK050C-0300-NN	4.700	5	5,5	–	–	15	3,1	3,4	–	–	12,4
MSK050C-0450-NN	6.000	5	5,5	–	–	15	4,7	5,2	–	–	18,8
MSK050C-0600-NN	6.000	5	5,5	–	–	15	6,2	6,8	–	–	24,8
MSK060B-0300-NN	4.800	5	5,5	–	–	15	3	3,3	–	–	12
MSK060B-0600-NN	6.000	5	5,5	–	–	15	6,1	6,7	–	–	24,4
MSK060C-0300-NN	4.900	8	8,8	12	–	24	4,8	5,3	7,2	–	19,2
MSK060C-0600-NN	6.000	8	8,8	12	–	24	9,5	10,5	14,3	–	38
MSK061B-0300-NN	4.200	3,5	3,9	–	–	14	1,9	2,1	–	–	8,6
MSK061C-0200-NN	3.100	8	9	12	–	32	3,2	3,6	4,8	–	14,4
MSK061C-0300-NN	4.200	8	9	12	–	32	4,3	4,8	6,5	–	19,4
MSK061C-0600-NN	6.000	8	9	12	–	32	7,7	8,7	11,6	–	34,7
MSK070C-0150-NN	2.500	13	14,5	19,5	–	33	4,1	4,6	6,2	–	12,6
MSK070C-0300-NN	5.500	13	14,5	19,5	–	33	8,2	9,2	12,3	–	25
MSK070C-0450-NN	6.000	13	14,5	19,5	–	33	12,3	13,7	18,5	–	36,9
MSK070D-0150-NN	2.700	17,5	20	26,3	–	52,5	6,2	7,1	9,3	–	24,8
MSK070D-0300-NN	4.900	17,5	20	26,3	–	52,5	11	12,6	16,5	–	33
MSK070D-0450-NN	6.000	17,5	20	26,3	–	52,5	16,6	22	24,9	–	49,8
MSK070E-0150-NN	2.200	23	25	34,5	–	70	6,4	7	9,6	–	25,6
MSK070E-0300-NN	5.300	23	25	34,5	–	65	15,4	16,7	23,1	–	49,3
MSK070E-0450-NN	6.000	23	25	34,5	–	60	19,3	21	29	–	57,9
MSK071C-0200-NN	3.500	12	14	18	22,8	44	5,2	6,1	7,8	9,9	23,4
MSK071C-0300-NN	5.000	12	14	18	22,8	44	7,3	8,5	11	13,9	32,9
MSK071C-0450-NN	5.800	12	14	18	22,8	44	8,9	10,4	13,4	16,9	40,1
MSK071D-0200-NN	3.200	17,5	20	26,3	33,3	66	7,3	8,6	11	13,9	32,8
MSK071D-0300-NN	3.800	17,5	20	26,3	33,3	66	9,1	10,7	13,5	17,2	40,5
MSK071D-0450-NN	6.000	17,5	20	26,3	33,3	66	15,4	17,6	23,1	30,3	69,3
MSK071E-0200-NN	3.400	23	28	34,5	43,7	84	10,1	12,6	15,2	19	45,5
MSK071E-0300-NN	4.200	23	28	34,5	43,7	84	12,5	15,2	18,8	24,9	56,3
MSK071E-0450-NN	6.000	23	28	34,5	43,7	84	20	24,4	30	38	90,1
MSK075C-0200-NN	4.100	12	12,5	18	–	44	6,3	7,3	9,5	–	28,4
MSK075C-0300-NN	5.000	12	12,5	18	–	44	8,4	8,8	12,6	–	37,8
MSK075C-0450-NN	6.000	12	12,5	18	–	44	12,6	13,1	18,9	–	56,7
MSK075D-0200-NN	3.800	17	18,5	25,5	–	64	8,3	9	12,5	–	37,4
MSK075D-0300-NN	4.800	17	18,5	25,5	–	66	11,7	12,7	17,6	–	52,7
MSK075D-0450-NN	6.000	17	18,5	25,5	–	64	16,5	18	24,8	–	74,3
MSK075E-0200-NN	3.850	21	23	31,5	–	88	10,2	11,2	15,3	–	45,9
MSK075E-0300-NN	5.200	21	23	31,5	39,9	88	14,2	15,6	21,3	27	63,9
MSK075E-0450-NN	6.000	21	23	31,5	39,9	88	18,6	20,4	27,9	35,3	83,7
MSK076C-0300-NN	4.700	12	13,5	18	–	43,5	7,2	8,1	10,8	–	32,4
MSK076C-0450-NN	5.000	12	13,5	18	–	43,5	12,2	13,7	18,3	–	54,9

All specifications relate to the basic version of the motor with encoder S1, without holding brake

<sup>1)</sup> At 750 V DC bus voltage

<sup>2)</sup> S = Fan cooled. / L = Liquid cooled

<sup>3)</sup> Flange size 150 mm for MSK071 with liquid cooling system

Type	Moment of inertia	Dimensions										Weight		
		J	A	B	B_S <sup>2)</sup>	B_L <sup>2)</sup>	C	Ø D	Ø E	Ø F	Ø G		H	m
		kgm <sup>2</sup>	mm	mm	mm	mm	mm	mm	mm	mm	mm		mm	kg
MSK030B-0900-NN	0,000013	54	152,5	—	—	20	9	40	63	4,5	98,5	1,3		
MSK030C-0900-NN	0,00003	54	188	—	—	20	9	40	63	4,5	98,5	1,9		
MSK040B-0450-NN	0,0001	82	155,5	—	—	30	14	50	95	6,6	124,5	2,8		
MSK040B-0600-NN	0,0001	82	155,5	—	—	30	14	50	95	6,6	124,5	2,8		
MSK040C-0450-NN	0,00014	82	185,5	—	—	30	14	50	95	6,6	124,5	3,6		
MSK040C-0600-NN	0,00014	82	185,5	—	—	30	14	50	95	6,6	124,5	3,6		
MSK043C-0600-NN	0,000083	82	185,5	—	—	30	14	50	95	6,6	124,5	3,6		
MSK050B-0300-NN	0,00028	98	173	—	—	40	19	95	115	9	134,5	4		
MSK050B-0450-NN	0,00028	98	173	—	—	40	19	95	115	9	134,5	4		
MSK050B-0600-NN	0,00028	98	173	—	—	40	19	95	115	9	134,5	4		
MSK050C-0300-NN	0,00033	98	203	—	—	40	19	95	115	9	134,5	5,4		
MSK050C-0450-NN	0,00033	98	203	—	—	40	19	95	115	9	134,5	5,4		
MSK050C-0600-NN	0,00033	98	203	—	—	40	19	95	115	9	134,5	5,4		
MSK060B-0300-NN	0,00048	116	181	—	—	50	24	95	130	9	156	5,7		
MSK060B-0600-NN	0,00048	116	181	—	—	50	24	95	130	9	156	5,7		
MSK060C-0300-NN	0,0008	116	226	395	—	50	24	95	130	9	156	8,4		
MSK060C-0600-NN	0,0008	116	226	395	—	50	24	95	130	9	156	8,4		
MSK061B-0300-NN	0,00044	116	223	—	—	40	19	95	130	9	156	5,7		
MSK061C-0200-NN	0,000752	116	264	432	—	40	19	95	130	9	156	8,3		
MSK061C-0300-NN	0,000752	116	264	432	—	40	19	95	130	9	156	8,3		
MSK061C-0600-NN	0,000752	116	264	432	—	40	19	95	130	9	156	8,3		
MSK070C-0150-NN	0,00291	140	238	429	—	58	32	130	165	11	202	11,7		
MSK070C-0300-NN	0,00291	140	238	429	—	58	32	130	165	11	202	11,7		
MSK070C-0450-NN	0,00291	140	238	429	—	58	32	130	165	11	202	11,7		
MSK070D-0150-NN	0,00375	140	268	459	—	58	32	130	165	11	202	14		
MSK070D-0300-NN	0,00375	140	268	459	—	58	32	130	165	11	202	14		
MSK070D-0450-NN	0,00375	140	268	459	—	58	32	130	165	11	202	14		
MSK070E-0150-NN	0,00458	140	298	489	—	58	32	130	165	11	202	16,2		
MSK070E-0300-NN	0,00458	140	298	489	—	58	32	130	165	11	202	16,2		
MSK070E-0450-NN	0,00458	140	298	489	—	58	32	130	165	11	202	16,2		
MSK071C-0200-NN	0,00173	140 <sup>3)</sup>	272	463	276	58	32	130	165	11	202	13,9		
MSK071C-0300-NN	0,00173	140 <sup>3)</sup>	272	463	276	58	32	130	165	11	202	13,9		
MSK071C-0450-NN	0,00173	140 <sup>3)</sup>	272	463	276	58	32	130	165	11	202	13,9		
MSK071D-0200-NN	0,0023	140 <sup>3)</sup>	312	503	316	58	32	130	165	11	202	18		
MSK071D-0300-NN	0,0023	140 <sup>3)</sup>	312	503	316	58	32	130	165	11	202	18		
MSK071D-0450-NN	0,0023	140 <sup>3)</sup>	312	503	316	58	32	130	165	11	202	18		
MSK071E-0200-NN	0,0029	140 <sup>3)</sup>	352	543	356	58	32	130	165	11	202	23,5		
MSK071E-0300-NN	0,0029	140 <sup>3)</sup>	352	543	356	58	32	130	165	11	202	23,5		
MSK071E-0450-NN	0,0029	140 <sup>3)</sup>	352	543	356	58	32	130	165	11	202	23,5		
MSK075C-0200-NN	0,00352	140	307	498	—	58	32	130	165	11	202	14,8		
MSK075C-0300-NN	0,00352	140	307	498	—	58	32	130	165	11	202	14,8		
MSK075C-0450-NN	0,00352	140	307	498	—	58	32	130	165	11	202	14,8		
MSK075D-0200-NN	0,0049	140	347	538	—	58	32	130	165	11	202	19		
MSK075D-0300-NN	0,0049	140	347	538	—	58	32	130	165	11	202	19		
MSK075D-0450-NN	0,0049	140	347	538	—	58	32	130	165	11	202	19		
MSK075E-0200-NN	0,00613	140	387	578	391	58	32	130	165	11	202	22,5		
MSK075E-0300-NN	0,00613	140	387	578	391	58	32	130	165	11	202	22,5		
MSK075E-0450-NN	0,00613	140	387	578	391	58	32	130	165	11	202	22,5		
MSK076C-0300-NN	0,0043	140	292,5	462	—	50	24	110	165	11	180	13,8		
MSK076C-0450-NN	0,0043	140	292,5	462	—	50	24	110	165	11	180	13,8		

# IndraDyn S – technical data

Type	Maximum speed <sup>1)</sup>	Continuous torque at standstill				Maximum torque	Continuous current at standstill				Maximum current
		60K	100K	Blower	F cooling		60K	100K	Blower	F cooling	
	$n_{Max}$ rpm	$M_{0,60}$ Nm	$M_{0,100}$ Nm	$M_{0,S}^{2)}$ Nm	$M_{0,L}^{2)}$ Nm	$M_{Max}$ Nm	$I_{0,60}$ A	$I_{0,100}$ A	$I_{0,S}^{2)}$ A	$I_{0,L}^{2)}$ A	$I_{Max}$ A
MSK100A-0200-NN	4.400	15	17	22,5	–	54	9,2	10,4	13,8	–	41,4
MSK100A-0300-NN	5.200	15	17	22,5	–	54	10,2	11,6	15,3	–	45,9
MSK100A-0450-NN	6.000	15	17	22,5	–	54	12	13,6	18	–	54
MSK100B-0200-NN	4.100	28	33	42	–	102	14,7	17,3	22,1	–	66,2
MSK100B-0300-NN	4.500	28	33	42	–	102	17,4	20,5	26,1	–	78,3
MSK100B-0400-NN	4.500	28	33	42	–	102	24,5	29,5	35,6	–	106,7
MSK100B-0450-NN	4.500	28	33	42	–	102	28,5	33,6	42,8	–	110,7
MSK100C-0200-NN	3.500	38	43,5	57	–	148	17,7	20,3	26,6	–	79,7
MSK100C-0300-NN	4.500	38	43,5	57	–	148	21,6	27	32,4	–	97,2
MSK100C-0450-NN	4.000	38	43,5	57	–	148	35,4	43,5	52,9	–	159,3
MSK100D-0200-NN	2.000	48	57	72	–	187	13	15,4	19,5	–	58,5
MSK100D-0300-NN	3.000	48	57	72	–	187	20,7	24,8	31,1	–	93,2
MSK100D-0350-NN	3.000	48	57	72	–	185	29,9	35,5	44,9	–	135
MSK101C-0200-NN	3.300	32	36,5	48	60,8	110	14,9	17	22,4	28,3	67,1
MSK101C-0300-NN	4.500	32	36,5	48	60,8	110	18,7	21,3	28,1	35,3	84,2
MSK101C-0450-NN	5.800	32	36,5	48	60,8	110	25,1	28,6	37,7	47,7	113
MSK101D-0200-NN	3.400	50	57	75	95	160	22,2	26,8	33,3	43,3	99,9
MSK101D-0300-NN	4.600	50	57	75	95	160	30,6	34,9	45,9	58,1	137,7
MSK101D-0450-NN	6.000	50	57	75	95	160	41,7	50,6	66	79,2	187,7
MSK101E-0200-NN	3.500	70	80,5	105,5	133	231	32,1	39	48,2	63,8	144,5
MSK101E-0300-NN	4.600	70	80,5	105	133	231	41,6	47,8	62,4	79	187,4
MSK101E-0450-NN	6.000	70	80,5	105	116	231	58,3	67,6	87,5	97	262,4
MSK103A-0300-NN	4.800	21	24	–	–	51	12,5	14,3	–	–	40
MSK103B-0300-NN	4.700	28	31	–	–	85	17	19	–	–	63
MSK103D-0300-NN	4.600	46	53	–	–	138	26,3	30,8	–	–	94,7
MSK131B-0200-NN	3.200	85	–	127,5	–	250	36,7	–	55,1	–	165
MSK131D-0200-NN	3.000	160	–	240	–	495	65,2	–	97,8	–	293,4
MSK133B-0202-SA	3.300	–	–	152	–	320	–	–	63	–	160
MSK133C-0202-SA	3.300	–	–	204	–	425	–	–	81	–	205
MSK133D-0202-SA	3.300	–	–	263	–	520	–	–	100	–	265
MSK133E-0202-SA	3.300	–	–	293	–	631	–	–	115	–	305
MSK133B-0203-FN	3.300	–	–	–	162	300	–	–	–	69,4	160
MSK133C-0203-FN	3.300	–	–	–	232,5	400	–	–	–	93	205
MSK133D-0203-FN	3.300	–	–	–	290	500	–	–	–	122,2	265
MSK133E-0203-FN	3.300	–	–	–	342	583	–	–	–	135,5	305

All specifications relate to the basic version of the motor with encoder S1, without holding brake

<sup>1)</sup> At 750 V DC bus voltage

<sup>2)</sup> S = Fan cooled. / L = Liquid cooled

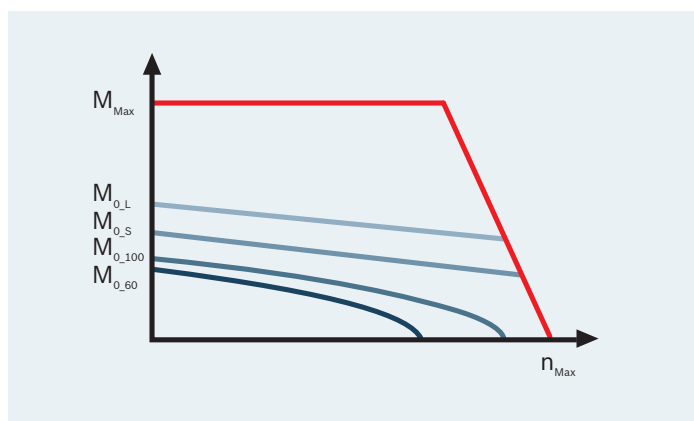



Type	Moment of inertia	Dimensions										Weight		
		J	A	B	B <sub>S</sub> <sup>2)</sup>	B <sub>L</sub> <sup>2)</sup>	C	Ø D	Ø E	Ø F	Ø G		H	m
		kgm <sup>2</sup>	mm	mm	mm	mm	mm	mm	mm	mm	mm		mm	kg
MSK100A-0200-NN	0,011	192	302	475	—	60	32	130	215	14	262	23		
MSK100A-0300-NN	0,011	192	302	475	—	60	32	130	215	14	262	23		
MSK100A-0450-NN	0,011	192	302	475	—	60	32	130	215	14	262	23		
MSK100B-0200-NN	0,0192	192	368	542	—	60	32	130	215	14	262	34		
MSK100B-0300-NN	0,0192	192	368	542	—	60	32	130	215	14	262	34		
MSK100B-0400-NN	0,0192	192	368	542	—	60	32	130	215	14	262	34		
MSK100B-0450-NN	0,0192	192	368	542	—	60	32	130	215	14	262	34		
MSK100C-0200-NN	0,0273	192	434	608	—	60	32	130	215	14	262	45,1		
MSK100C-0300-NN	0,0273	192	434	608	—	60	32	130	215	14	262	45,1		
MSK100C-0450-NN	0,0273	192	434	608	—	60	32	130	215	14	262	45,1		
MSK100D-0200-NN	0,035	192	502	676	—	60	32	130	215	14	262	56		
MSK100D-0300-NN	0,035	192	502	676	—	60	32	130	215	14	262	56		
MSK100D-0350-NN	0,035	192	502	676	—	60	32	130	215	14	262	56		
MSK101C-0200-NN	0,0065	192	349	523	349	80	38	180	215	14	262	28,3		
MSK101C-0300-NN	0,0065	192	349	523	349	80	38	180	215	14	262	28,3		
MSK101C-0450-NN	0,0065	192	349	523	349	80	38	180	215	14	262	28,3		
MSK101D-0200-NN	0,00932	192	410	584	412	80	38	180	215	14	262	40		
MSK101D-0300-NN	0,00932	192	410	584	412	80	38	180	215	14	262	40		
MSK101D-0450-NN	0,00932	192	410	584	412	80	38	180	215	14	262	40		
MSK101E-0200-NN	0,0138	192	501	675	502	80	38	180	215	14	262	53,5		
MSK101E-0300-NN	0,0138	192	501	675	502	80	38	180	215	14	262	53,5		
MSK101E-0450-NN	0,0138	192	501	675	502	80	38	180	215	14	262	53,5		
MSK103A-0300-NN	0,00442	192	186	—	—	80	38	180	215	14	255	18		
MSK103B-0300-NN	0,00594	192	211	—	—	80	38	180	215	14	255	22,5		
MSK103D-0300-NN	0,00894	192	265	—	—	80	38	180	215	14	255	31,6		
MSK131B-0200-NN	0,0232	260	470	685	—	110	48	250	300	18	337	84		
MSK131D-0200-NN	0,0382	260	610	825	—	110	48	250	300	18	337	116		
MSK133B-0202-SA	0,0476	260	—	582	—	110	48	250	300	18	346	91,6		
MSK133C-0202-SA	0,068	260	—	632	—	110	48	250	300	18	370	111		
MSK133D-0202-SA	0,078	260	—	682	—	110	48	250	300	18	370	127		
MSK133E-0202-SA	0,09	260	—	732	—	110	48	250	300	18	370	146		
MSK133B-0203-FN	0,0476	260	—	—	445	110	48	250	300	18	346	91,6		
MSK133C-0203-FN	0,068	260	—	—	495	110	48	250	300	18	370	111		
MSK133D-0203-FN	0,078	260	—	—	545	110	48	250	300	18	370	127		
MSK133E-0203-FN	0,09	260	—	—	595	110	48	250	300	18	370	146		

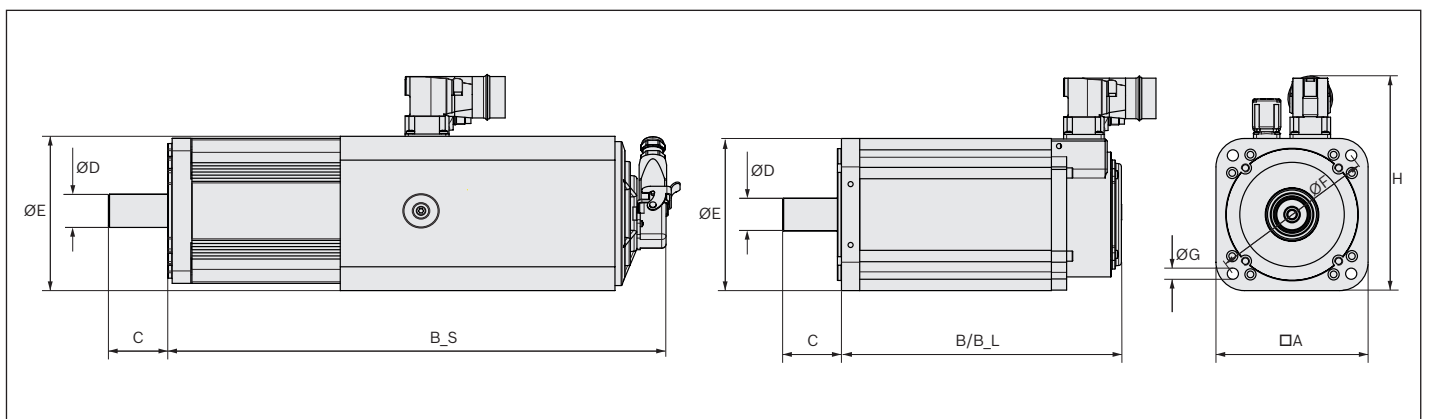

# IndraDyn S – MKE servo motors for potentially explosive areas

The MKE range of motors are specifically designed for use in production plants where an explosive mixture of air and flammable gases, vapors, mist or dust can occur:

- ▶ Chemical industry
- ▶ Mining
- ▶ Printing shops
- ▶ Woodworking
- ▶ Paint shops
- ▶ Mills
- ▶ Food processing industry
- ▶ Refineries
- ▶ Tank farms, and much more

Within the broad range of torques up to a maximum of 187 Nm, there is a choice of various sizes of motor with flameproof enclosures. Needless to say, all are ATEX certified and/or UL/CSA compliant. These motors can also be supplied with a range of options – holding brake, keyway and single-turn or multi-turn encoder systems.



## Internationally recognized certification

MKE motors have been certified as explosion-protected equipment by the German metrology institute providing scientific and technical services, the PTB Braunschweig, in accordance with Directive 94/9/EC.

With their explosion-proof enclosure, MKE motors are suitable for use in areas with flammable gases and vapors as specified in EN 60079-0/-1 (marking: II 2G Ex d IIB T4 Gb X) as well as flammable dusts according to EN 60079-31 (marking: II 2D Ex tc IIIC T135°C Dc IP6X X).

The certificates are recognized by all member states of the European Union as well as non-European members of the CENELEC.

MKE motors based on the American standard (UL/CSA) were certified directly by Underwriters Laboratories Inc. (UL) in the USA for use in areas with flammable gases, vapors and dusts in accordance with UL674 (marking: Class I Division 1 Groups C, D). MKE098 and MKE118 also have the marking Class II Division 1 Groups F, G.



**MKE as per ATEX –**  
terminal box with Ex d  
cable connectors



**MKE as per UL/CSA –**  
terminal box with cables for  
conduit installation

## Ultra-safe

- ▶ Maximum torques up to 187 Nm
- ▶ Maximum speeds up to 9,000 rpm
- ▶ Range of encoder systems
- ▶ Explosion-proof enclosure
- ▶ Compliance with ATEX and UL/CSA

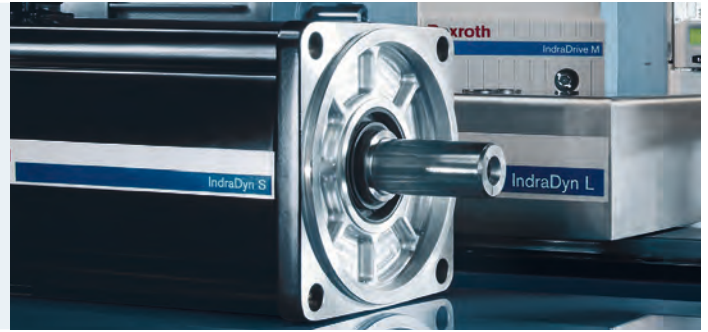

Motor		Maximum speed <sup>1)</sup>	Continuous torque at standstill 60K	Maximum torque	Continuous current at standstill 60K	Maximum current	Moment of inertia	Dimensions							Weight <sup>2)</sup>	
		$n_{Max}$	$M_{0,60}$	$M_{Max}$	$I_{0,60}$	$I_{Max}$	$J_R$	A	B	C	Ø D	Ø E	Ø F	Ø G	H	m
		rpm	Nm	Nm	A	A	kgm <sup>2</sup>	mm	mm	mm	mm	mm	mm	mm	mm	kg
MKE037	B-144	9,000	0.9	4	3.3	15	0.00003	60	283	20	9	40	70	4.5	123	2.5/2.8
MKE047	B-144	7,000	2.7	11.3	5	22.6	0.00017	88	287	30	14	50	100	6.6	146	5.5/5.8
MKE098	B-047	4,500	12	43.5	9.8	44.3	0.0043	144	383	50	24	110	165	11	202	18/19.1
	B-058	5,000	12	43.5	12.4	55.9	0.0043	144	383	50	24	110	165	11	202	18/19.1
MKE118	B-024	4,000	28	102	15.3	69.1	0.0194	194	492	60	32	130	215	14	205	45/46
	B-058	4,500	28	102	28.4	127.6	0.0194	194	492	60	32	130	215	14	205	45/46
	D-012	2,000	48	187	13	58.5	0.0362	194	664	60	32	130	215	14	205	65/69.1
	D-027	3,000	48	187	22.1	99.6	0.0362	194	664	60	32	130	215	14	205	65/69.1
	D-035	3,000	48	187	29.8	134.3	0.0362	194	664	60	32	130	215	14	205	65/69.1

All specifications relate to the basic version of the motor with encoder A and without holding brake

<sup>1)</sup> At 750 V DC bus voltage; <sup>2)</sup> Values without/with holding brake

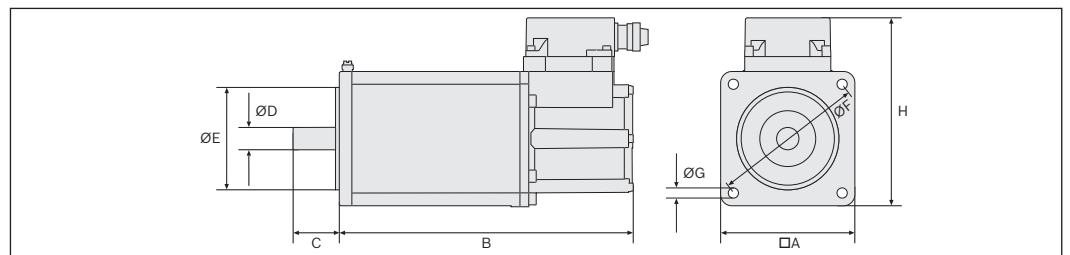
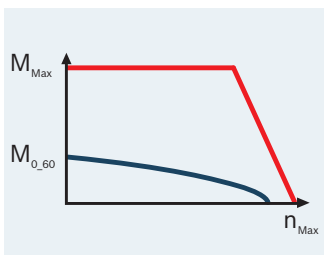

The simple step-by-step guide to ordering your MKE servo motor:

### MKE037B-144-AG0-BENN

#### Motor

- ▶ Overall size (e.g. "037")
- ▶ Overall length (e.g. "B")
- ▶ Winding (e.g. "144")

#### Encoder

- A** = Single-turn encoder (Hiperface®), 128 signal periods
- B<sup>1)</sup>** = Single-turn encoder (EnDat), 2,048 signal periods
- C** = Multi-turn encoder (Hiperface®), 128 signal periods with 4,096 revolutions absolute
- D<sup>1)</sup>** = Multi-turn encoder (EnDat), 2,048 signal periods with 4,096 revolutions absolute

#### Shaft

- G** = Plain shaft with shaft sealing ring
- P** = Keyway conforming to DIN 6885-1 and shaft sealing ring

<sup>1)</sup> Not applicable to MKE037 and MKE047

<sup>2)</sup> Version E only available with power connection option B

#### Cable entry

**4** = Ø 13 – 16 mm

**6** = Ø 17 – 19.5 mm

**N** = Conforming to American standard (UL)

#### Housing design

**E<sup>2)</sup>** = Conforming to European standard (ATEX)

**U** = Conforming to American standard (UL)

#### Line terminal

**A** = On the A side

**B** = On the B side

**L** = Left

**R** = Right

#### Holding brake

**0** = Without holding brake

**1** = With electr. released holding brake

# IndraDyn S – MSM servo motors for IndraDrive Cs

Maintenance-free MSM motors are available in five sizes rated at up to 750 W continuous mechanical power. These short-length motors feature high power density and minimized flange dimensions, making them the ideal choice in a wide range of application scenarios. The IP54 motors come with an absolute encoder and optional holding brake, and they can easily be connected to IndraDrive Cs power units with a 3 AC 230 V line input.



## Buffer battery for absolute encoder function

A buffer battery is needed for permanent storage of the axis position.

A battery box which is simple to install is available as an accessory.

Order code: SUP-E01-MSM-BATTERYBOX

As an alternative, the buffer voltage can be supplied directly at the power unit via a special encoder connector with additional terminal connections.

This permits the use of a central battery or an uninterruptible power supply (UPS) as a voltage supply – e.g. for a package consisting of several drives.

Order no. for D-SUB encoder connector with buffer voltage connection: RGS0001/K01

Order no. for pre-assembled encoder cable with RGS001 connector: RKG0041



## Dynamic and compact

- ▶ Maximum torques up to 7.1 Nm
- ▶ Maximum speeds up to 5,000 rpm
- ▶ Multi-turn absolute encoder
- ▶ High dynamic performance
- ▶ High performance density



Motor	Rated power	Continuous torque at standstill 60K	Maximum torque	Maximum speed	Moment of inertia	Dimensions								Weight <sup>1)</sup>
	$P_N$	$M_{0.60}$	$M_{Max}$	$n_{Max}$	$J_R$	A	B <sup>1)</sup>	C	Ø D	Ø E	Ø F	Ø G	H	m
	W	Nm	Nm	rpm	kgm <sup>2</sup>	mm	mm	mm	mm	mm	mm	mm	mm	kg
MSM019A	50	0.16	0.48	5,000	0.0000025	38	72/102	25	8	30	45	3.4	51	0.32/0.53
MSM019B	100	0.32	0.95	5,000	0.0000051	38	92/122	25	8	30	45	3.4	51	0.47/0.68
MSM031B	200	0.64	1.91	5,000	0.0000140	60	79/115.5	30	11	50	70	4.5	73	0.82/1.3
MSM031C	400	1.3	3.8	5,000	0.0000260	60	98.5/135	30	14	50	70	4.5	73	1.2/1.7
MSM041B	750	2.4	7.1	4,500	0.0000870	80	112/149	35	19	70	90	6	93	2.3/3.1

<sup>1)</sup> Values without/with holding brake

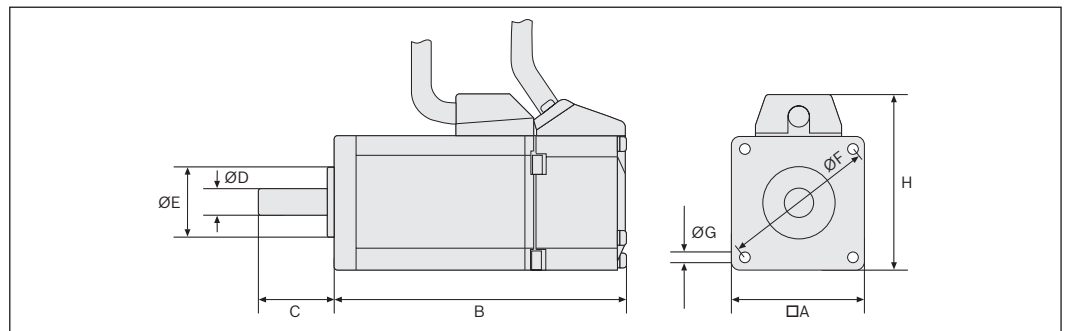
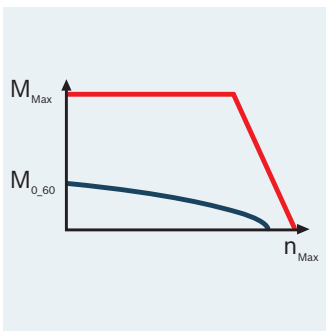

The simple step-by-step guide to ordering your MSM servo motor:

### MSM 019 B-0300-NN-M0-CH 1

#### Size

**019** = Flange 38 mm  
**031** = Flange 60 mm  
**041** = Flange 80 mm

#### Overall length (e.g. "B")

#### Winding

**0300** = Nominal speed 3000 rpm

#### Cooling system

**NN** = Natural convection

#### Encoder

**M0<sup>1)</sup>** = Digital multi-turn absolute encoder with encoder resolution of 17 bits/revolution, 65,536 distinguishable revolutions

#### Holding brake

**0** = Without holding brake  
**1** = With electrically released holding brake

#### Shaft

**H<sup>2)</sup>** = Plain shaft without shaft sealing ring

#### Electrical connection

**C** = 220 mm cable

<sup>1)</sup> Absolute encoder function with external buffer battery

<sup>2)</sup> Shaft sealing ring retrofit possible

# IndraDyn A – MAD air-cooled asynchronous servo motors

With their impressive power density, the MAD range of motors is predestined for servo and main spindle applications, such as in machine tools, printing presses or metal forming technology.

High-resolution single-turn or multi-turn encoder systems and outstanding true running quality guarantee highest handling precision. In addition to the optional keyway and holding brake, these motors can also be supplied with a special bearing assembly for high-speed applications or for applications with increased radial load.

The motor protection category IP65 even includes the fan motor, making it suitable for harsh industrial use.

The easy-maintenance design of the motor means that it is even possible to exchange the fan while the motor is running – particularly advantageous in the printing industry.



## Robust and easy-maintenance

- ▶ Rated outputs of up to 93 kW
- ▶ Maximum speeds up to 11,000 rpm
- ▶ Encoder systems for a wide and diverse range of applications
- ▶ High protection category IP65, including fan motor
- ▶ Easy-maintenance motor design



The simple step-by-step guide to ordering your MAD asynchronous servo motor:

**MAD 100C-0100-SA-S2-AH0-05-N 1**

### Motor

- ▶ Size (e.g. "100")
- ▶ Overall length (e.g. "C")
- ▶ Winding (e.g. "0100")

### Cooling system

- SA** = Axial-flow fan  
**SL** = Fan cowl

### Encoder

- S2** = Single-turn encoder (EnDat) 2,048 signal periods  
**M2** = Multi-turn encoder (EnDat) 2,048 signal periods with 4,096 revolutions absolute  
**S6<sup>2)</sup>** = Single-turn encoder (EnDat) 2,048 signal periods for potentially explosive atmospheres  
**M6<sup>2)</sup>** = Multi-turn encoder (EnDat) 2,048 signal periods with 4,096 revolutions absolute for potentially explosive atmospheres  
**C0** = Incremental encoder, 2,048 increments

### Line terminal

Plug<sup>1)</sup>

- A** = On the A side  
**B** = On the B side  
**L** = Left  
**R** = Right

Terminal box turntable

- E** = On the A side  
**H** = On the B side  
**G** = Left  
**D** = Right

<sup>1)</sup> Only for certain sizes

<sup>2)</sup> Equipment group II 2G, type of protection EEx p d IIB T3 only in combination with fan cowl cooling option SL

### Vibration severity grade

- 1** = A  
**3<sup>1)</sup>** = B  
**4<sup>1)</sup>** = C

### Bearing assembly

- N** = Standard  
**A<sup>1)</sup>** = Fixed bearing A side  
**H<sup>1)</sup>** = High-speed  
**V<sup>1)</sup>** = Heavy duty

### Construction

- 05** = Flange-mounted  
**35** = Flange-mounted or foot-mounted

### Holding brake

- 0** = Without holding brake  
**1** = With electr. released holding brake  
**3<sup>1)</sup>** = With electr. released holding brake, heavy duty  
**5<sup>1)</sup>** = With electr. clamped holding brake

### Shaft version e.g.

- Plain shaft  
**H** = Without seal ring  
**G** = With seal ring (IP65)  
**F** = With labyrinth seal Keyway  
**Q** = Without seal ring  
**P** = With seal ring (IP65)  
**R** = With labyrinth seal

# IndraDyn A – technical data

Motor		Rated speed	Maximum speed	Rated torque	Maximum torque	Rated power	Rated current	Moment of inertia	Dimensions							Weight	
		$n_N$	$n_{Max}$	$M_N$	$M_{Max}$	$P_N$	$I_N$	$J_R$	A	B	C	Ø D	Ø E	Ø F	Ø G	H <sup>1)</sup>	m
		rpm	rpm	Nm	Nm	kW	A	kgm <sup>2</sup>	mm	mm	mm	mm	mm	mm	mm	mm	kg
MAD100	B-0050	500	3,000	34	75.1	1.8	5.3	0.019	192 <sup>2)</sup>	462	60	32	130	215	14	287	43
	B-0100	1,000	6,000	31	74.7	3.2	8.9	0.019	192 <sup>2)</sup>	462	60	32	130	215	14	287	43
	B-0150	1,500	9,000	30	68	4.7	12.9	0.019	192 <sup>2)</sup>	462	60	32	130	215	14	287	43
	B-0200	2,000	11,000	28	66.2	5.9	14.6	0.019	192 <sup>2)</sup>	462	60	32	130	215	14	287	43
	B-0250	2,500	11,000	25	61.5	6.5	16.2	0.019	192 <sup>2)</sup>	462	60	32	130	215	14	287	43
	C-0050	500	3,000	51	112.3	2.7	8.2	0.0284	192 <sup>2)</sup>	537	60	32	130	215	14	287	59
	C-0100	1,000	6,000	50	118.8	5.2	13.2	0.0284	192 <sup>2)</sup>	537	60	32	130	215	14	287	59
	C-0150	1,500	9,000	48	110.4	7.5	19.7	0.0284	192 <sup>2)</sup>	537	60	32	130	215	14	287	59
	C-0200	2,000	11,000	45	105.5	9.4	25.7	0.0284	192 <sup>2)</sup>	537	60	32	130	215	14	287	59
	C-0250	2,500	11,000	40	91	10.5	27.8	0.0284	192 <sup>2)</sup>	537	60	32	130	215	14	287	59
	D-0050	500	3,000	70	153.6	3.7	10.1	0.0392	192 <sup>2)</sup>	612	60	32	130	215	14	287	72
	D-0100	1,000	6,000	64	146.5	6.7	19.3	0.0392	192 <sup>2)</sup>	612	60	32	130	215	14	287	72
D-0150	1,500	9,000	59	140.8	9.3	25.6	0.0392	192 <sup>2)</sup>	612	60	32	130	215	14	287	72	
D-0200	2,000	11,000	54	129.8	11.3	27.2	0.0392	192 <sup>2)</sup>	612	60	32	130	215	14	287	72	
D-0250	2,500	11,000	50	118.7	13.1	32.4	0.0392	192 <sup>2)</sup>	612	60	32	130	215	14	287	72	
MAD130	B-0050	500	3,000	95	208.8	5	12.8	0.084	260 <sup>2)</sup>	570	110	42	250	300	18	368	100
	B-0100	1,000	6,000	100	230	10.5	26.9	0.084	260 <sup>2)</sup>	570	110	42	250	300	18	368	100
	B-0150	1,500	9,000	85	200	13.4	34.9	0.084	260 <sup>2)</sup>	570	110	42	250	300	18	368	100
	B-0200	2,000	10,000	80	187.2	16.8	43	0.084	260 <sup>2)</sup>	570	110	42	250	300	18	368	100
	B-0250	2,500	10,000	75	176.5	19.6	47.2	0.084	260 <sup>2)</sup>	570	110	42	250	300	18	368	100
	C-0050	500	3,000	140	307.9	7.3	19.7	0.108	260 <sup>2)</sup>	640	110	42	250	300	18	368	122
	C-0100	1,000	6,000	125	305	13.1	36.2	0.108	260 <sup>2)</sup>	640	110	42	250	300	18	368	122
	C-0150	1,500	9,000	117	275.2	18.4	48.9	0.108	260 <sup>2)</sup>	640	110	42	250	300	18	368	122
	C-0200	2,000	10,000	110	252.9	23	57	0.108	260 <sup>2)</sup>	640	110	42	250	300	18	368	122
	C-0250	2,500	10,000	100	250	26.2	62	0.108	260 <sup>2)</sup>	640	110	42	250	300	18	368	122
	D-0050	500	3,000	180	395.6	9.4	24.2	0.164	260 <sup>2)</sup>	770	110	42	250	300	18	368	165
	D-0100	1,000	6,000	170	417.8	17.8	43.7	0.164	260 <sup>2)</sup>	770	110	42	250	300	18	368	165
D-0150	1,500	9,000	155	374.6	24.3	61.5	0.164	260 <sup>2)</sup>	770	110	42	250	300	18	368	165	
D-0200	2,000	10,000	150	340.7	31.4	71.3	0.164	260 <sup>2)</sup>	770	110	42	250	300	18	368	165	
D-0250	2,500	10,000	120	310	31.4	72	0.164	260 <sup>2)</sup>	770	110	42	250	300	18	368	165	
MAD160	B-0050	500	3,000	220	483.9	11.5	26.1	0.25	316	748	110	55	300	350	18	420	201
	B-0100	1,000	6,000	200	520	20.9	43.5	0.25	316	748	110	55	300	350	18	420	201
	B-0150	1,500	6,000	190	440.1	29.9	61.6	0.25	316	748	110	55	300	350	18	420	201
	B-0200	2,000	6,000	160	375.3	33.5	75.8	0.25	316	748	110	55	300	350	18	420	201
	C-0050	500	3,000	240	528.2	12.6	27.6	0.311	316	838	110	55	300	350	18	420	238
	C-0100	1,000	6,000	225	530	23.6	52.9	0.311	316	838	110	55	300	350	18	420	238
	C-0150	1,500	6,000	215	496	33.8	75.3	0.311	316	838	110	55	300	350	18	420	238
C-0200	2,000	6,000	210	494.2	44	93.9	0.311	316	838	110	55	300	350	18	420	238	
MAD180	C-0050	500	3,000	325	715.5	17	38.2	0.458	320 <sup>2)</sup>	979	140	60	300	350	18	469	334
	C-0100	1,000	6,000	300	620	31.4	69	0.458	320 <sup>2)</sup>	979	140	60	300	350	18	447	334
	C-0150	1,500	6,000	270	681	42.4	88.6	0.458	320 <sup>2)</sup>	979	140	60	300	350	18	447	334
	C-0200	2,000	6,000	250	594.4	52.4	104.6	0.458	320 <sup>2)</sup>	979	140	60	300	350	18	447	334
	D-0050	500	3,000	390	857.8	20.4	39.7	0.594	320 <sup>2)</sup>	1,089	140	60	300	350	18	447	403
	D-0100	1,000	6,000	370	901.5	38.7	82.4	0.594	320 <sup>2)</sup>	1,089	140	60	300	350	18	447	403
	D-0150	1,500	6,000	340	794	53.4	107.4	0.594	320 <sup>2)</sup>	1,089	140	60	300	350	18	447	403
D-0200	2,000	6,000	300	768.2	62.8	117.4	0.594	320 <sup>2)</sup>	1,089	140	60	300	350	18	447	403	



Motor	Rated speed	Maximum speed	Rated torque	Maximum torque	Rated power	Rated current	Moment of inertia	Dimensions								Weight	
	$n_N$	$n_{Max}$	$M_N$	$M_{Max}$	$P_N$	$I_N$	$J_R$	A	B	C	$\varnothing D$	$\varnothing E$	$\varnothing F$	$\varnothing G$	$H^{1)}$	m	
	rpm	rpm	Nm	Nm	kW	A	kgm <sup>2</sup>	mm	mm	mm	mm	mm	mm	mm	mm	kg	
MAD225	C-0050	500	3,000	660	1,450	34.6	72	1.65	434 <sup>2)</sup>	1,240	140	75	350	400	18	572	610
	C-0100	1,000	3,750	640	1,450	67	121	1.65	434 <sup>2)</sup>	1,240	140	75	350	400	18	572	610
	C-0150	1,500	3,750	593	1,450	93.1	174	1.65	434 <sup>2)</sup>	1,240	140	75	350	400	18	572	610

All the specifications given relate to the basic version of the motor without a holding brake. The maximum speed depends on the bearing version.

<sup>1)</sup> Motor height H for version with terminal box, the values for a power connection with plug can deviate and are as follows:

MAD100 = 260 mm, MAD130 = 338 mm, MAD160 = 393 mm

<sup>2)</sup> Housing size > flange size A

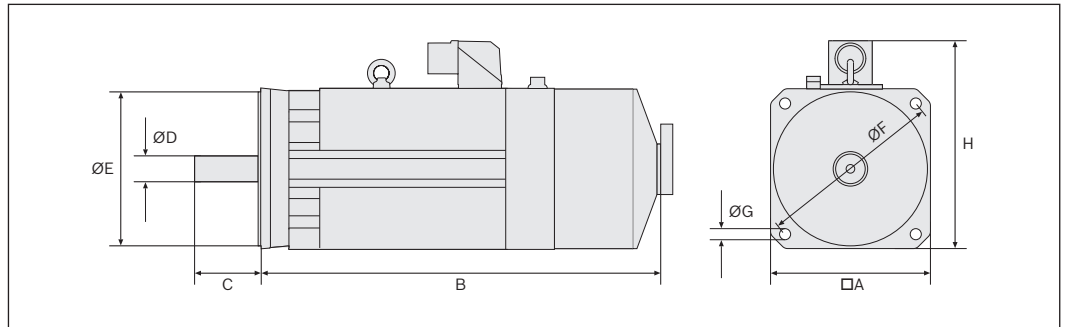
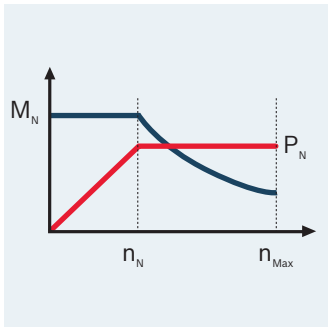

# IndraDyn A – MAF liquid-cooled asynchronous servo motors

The liquid-cooled motors in the MAF series are particularly suitable for applications demanding maximum torques in minimum amounts of space. At the same time the unique cooling system design ensures the thermal isolation of motor and machine and therefore maximum handling precision. The quick couplings with integrated leak-proofing simplify your maintenance work.

Options such as holding brakes, different encoder systems, vibration severity grades and shaft specifications allow you to tailor the MAF motors optimally to your specific application.



## Compact and powerful

- ▶ Rated outputs of up to 120 kW
- ▶ Maximum speeds up to 11,000 rpm
- ▶ Encoder systems for a wide and diverse range of applications
- ▶ High protection category IP65
- ▶ Liquid cooling with quick coupling



The simple step-by-step guide to ordering your MAF asynchronous servo motor:

**MAF 100C-0100-FQ-S2-AH0-05-N 1**

### Motor

- ▶ Size (e.g. "100")
- ▶ Overall length (e.g. "C")
- ▶ Winding (e.g. "0100")

### Cooling system connection

- FQ** = Connection thread  
**FR** = Quick coupling (comprised in the delivery)

### Encoder

- S2** = Single-turn encoder (EnDat), 2,048 signal periods  
**M2** = Multi-turn encoder (EnDat) 2,048 signal periods with 4,096 revolutions absolute  
**S6<sup>2)</sup>** = Single-turn encoder (EnDat), 2,048 signal periods for potentially explosive atmospheres  
**M6<sup>2)</sup>** = Multi-turn encoder (EnDat), 2,048 signal periods with 4,096 revolutions absolute for potentially explosive atmospheres  
**C0** = Incremental encoder, 2,048 increments

### Line terminal

- Plug<sup>1)</sup>  
**A** = On the A side  
**B** = On the B side  
**L** = Left  
**R** = Right  
 Terminal box turntable  
**E** = On the A side  
**H** = On the B side  
**G** = Left  
**D** = Right

### Vibration severity grade

- 1** = A  
**3<sup>1)</sup>** = B  
**4<sup>1)</sup>** = C

### Bearing assembly

- N** = Standard  
**A<sup>1)</sup>** = Fixed bearing A side  
**H<sup>1)</sup>** = High-speed  
**V<sup>1)</sup>** = Heavy duty

### Construction

- 05** = Flange-mounted  
**35** = Flange-mounted or foot-mounted

### Holding brake

- 0** = Without holding brake  
**1** = With electr. released holding brake  
**3<sup>1)</sup>** = With electr. released holding brake, heavy duty  
**5<sup>1)</sup>** = With electr. clamped holding brake

### Shaft version e.g.

- Plain shaft  
**H** = Without seal ring  
**G** = With seal ring (IP65)  
**F** = With labyrinth seal  
 Keyway  
**Q** = Without seal ring  
**P** = With seal ring (IP65)  
**R** = With labyrinth seal

<sup>1)</sup> Only for certain sizes

<sup>2)</sup> Equipment group II 2G, type of protection EEx p d IIB T3 only in combination with fan cowl cooling option SL

# IndraDyn A – technical data

Motor		Rated speed	Maximum speed	Rated torque	Maximum torque	Rated power	Rated current	Moment of inertia	Dimensions							Weight	
		$n_N$	$n_{Max}$	$M_N$	$M_{Max}$	$P_N$	$I_N$	$J_R$	A	B	C	Ø D	Ø E	Ø F	Ø G	H <sup>1)</sup>	m
		rpm	rpm	Nm	Nm	kW	A	kgm <sup>2</sup>	mm	mm	mm	mm	mm	mm	mm	mm	kg
MAF100	B-0050	500	3,000	50	109.7	2.6	8.5	0.019	192	382	60	38	130	215	14	287	38
	B-0100	1,000	6,000	46	110	4.8	15.2	0.019	192	382	60	38	130	215	14	287	38
	B-0150	1,500	9,000	42	101.4	6.6	18.1	0.019	192	382	60	38	130	215	14	287	38
	B-0200	2,000	11,000	38	92.4	8	23.9	0.019	192	382	60	38	130	215	14	287	38
	B-0250	2,500	11,000	33	83.6	8.6	26	0.019	192	382	60	38	130	215	14	287	38
	C-0050	500	3,000	70	153.7	3.9	12.1	0.0284	192	457	60	38	130	215	14	287	52
	C-0100	1,000	6,000	68	154	7.5	19	0.0284	192	457	60	38	130	215	14	287	52
	C-0150	1,500	9,000	66	149.5	10.4	27.9	0.0284	192	457	60	38	130	215	14	287	52
	C-0200	2,000	11,000	64	145.2	13.4	36.7	0.0284	192	457	60	38	130	215	14	287	52
	C-0250	2,500	11,000	62	138.1	16.2	40.2	0.0284	192	457	60	38	130	215	14	287	52
	D-0050	500	3,000	88	193.3	4.6	14.5	0.032	192	532	60	38	130	215	14	287	64
	D-0100	1,000	6,000	84	190	8.8	27.1	0.032	192	532	60	38	130	215	14	287	64
D-0150	1,500	9,000	79	185.3	12.4	32.7	0.032	192	532	60	38	130	215	14	287	64	
D-0200	2,000	11,000	80	182.3	16.8	43.1	0.032	192	532	60	38	130	215	14	287	64	
D-0250	2,500	11,000	75	177.5	19.6	45.8	0.032	192	532	60	38	130	215	14	287	64	
MAF130	B-0050	500	3,000	116	254.7	6.1	14.7	0.079	260	408	110	42	250	300	18	338	81
	B-0100	1,000	6,000	112	254.7	11.7	28.4	0.079	260	408	110	42	250	300	18	338	81
	B-0150	1,500	9,000	115	264	18.1	43.7	0.079	260	408	110	42	250	300	18	338	81
	B-0200	2,000	10,000	100	220	20.9	52.7	0.079	260	408	110	42	250	300	18	338	81
	B-0250	2,500	10,000	90	210	23.6	55.5	0.079	260	408	110	42	250	300	18	338	81
	C-0050	500	3,000	155	340	8.1	21	0.101	260	478	110	42	250	300	18	338	106
	C-0100	1,000	6,000	150	330	15.7	38	0.101	260	478	110	42	250	300	18	338	106
	C-0150	1,500	9,000	145	329.8	22.8	53.2	0.101	260	478	110	42	250	300	18	338	106
	C-0200	2,000	10,000	135	314.7	28.3	69.8	0.101	260	478	110	42	250	300	18	338	106
	C-0250	2,500	10,000	125	298.4	32.7	75.5	0.101	260	478	110	42	250	300	18	338	106
	D-0050	500	3,000	230	506.3	12	32.3	0.151	260	608	110	42	250	300	18	338	147
	D-0100	1,000	6,000	220	500	23	50.7	0.151	260	608	110	42	250	300	18	338	147
D-0150	1,500	9,000	200	484.4	31.4	72.6	0.151	260	608	110	42	250	300	18	338	147	
D-0200	2,000	10,000	200	461.4	41.9	93.9	0.151	260	608	110	42	250	300	18	338	147	
D-0250	2,500	10,000	190	432.1	49.7	113	0.151	260	608	110	42	250	300	18	338	147	
MAF160	B-0050	500	3,000	270	594.5	14.1	34.3	0.23	316	618	110	60	300	350	18	393	197
	B-0100	1,000	6,000	260	592.7	27.2	73.7	0.23	316	618	110	60	300	350	18	393	197
	B-0150	1,500	6,000	250	570.8	39.3	89.5	0.23	316	618	110	60	300	350	18	393	197
	B-0200	2,000	6,000	240	550.1	50.3	108.5	0.23	316	618	110	60	300	350	18	393	197
	C-0050	500	3,000	340	747.8	17.8	47.4	0.26	316	708	110	60	300	350	18	393	227
	C-0100	1,000	6,000	325	746.4	34	91.2	0.26	316	708	110	60	300	350	18	393	227
	C-0150	1,500	6,000	300	681.4	47.1	109.5	0.26	316	708	110	60	300	350	18	393	227
	C-0200	2,000	6,000	285	677.4	59.7	136	0.26	316	708	110	60	300	350	18	393	227
MAF180	C-0050	500	3,000	435	986.2	22.8	50	0.49	320 <sup>2)</sup>	792	140	60	300	350	18	449	322
	C-0100	1,000	6,000	400	957	41.9	93.9	0.49	320 <sup>2)</sup>	792	140	60	300	350	18	449	322
	C-0150	1,500	6,000	365	858.1	57.3	128.8	0.49	320 <sup>2)</sup>	792	140	60	300	350	18	449	322
	C-0200	2,000	6,000	318	739.2	66.6	154	0.49	320 <sup>2)</sup>	792	140	60	300	350	18	449	322
	D-0050	500	3,000	500	1,100.2	26.2	60.4	0.61	320 <sup>2)</sup>	902	140	60	300	350	18	449	382
	D-0100	1,000	6,000	460	1,094.5	48.2	94.8	0.61	320 <sup>2)</sup>	902	140	60	300	350	18	449	382
	D-0150	1,500	6,000	435	1,013	68.3	146.1	0.61	320 <sup>2)</sup>	902	140	60	300	350	18	449	382
D-0200	2,000	6,000	400	1,008	83.8	168.5	0.61	320 <sup>2)</sup>	902	140	60	300	350	18	449	382	

Motor		Rated speed	Maximum speed	Rated torque	Maximum torque	Rated power	Rated current	Moment of inertia	Dimensions								Weight
		$n_N$	$n_{Max}$	$M_N$	$M_{Max}$	$P_N$	$I_N$	$J_R$	A	B	C	$\varnothing D$	$\varnothing E$	$\varnothing F$	$\varnothing G$	$H^{1)}$	m
		rpm	rpm	Nm	Nm	kW	A	kgm <sup>2</sup>	mm	mm	mm	mm	mm	mm	mm	mm	kg
MAF225	C-0050	500	3,000	860	1,750	45	98	1.65	434 <sup>2)</sup>	932	140	75	350	400	18	572	587
	C-0100	1,000	3,750	820	1,750	85.9	170	1.65	434 <sup>2)</sup>	932	140	75	350	400	18	572	587
	C-0150	1,500	3,750	764	1,750	120	215	1.65	434 <sup>2)</sup>	932	140	75	350	400	18	572	587

All the specifications given relate to the basic version of the motor without a holding brake. The maximum speed depends on the bearing version.

<sup>1)</sup> Motor height H for version with terminal box, values for a power connection with plug can deviate and are as follows:

MAF100 = 260 mm, MAF130 = 338 mm, MAF160 = 393 mm

<sup>2)</sup> Housing size > flange size A

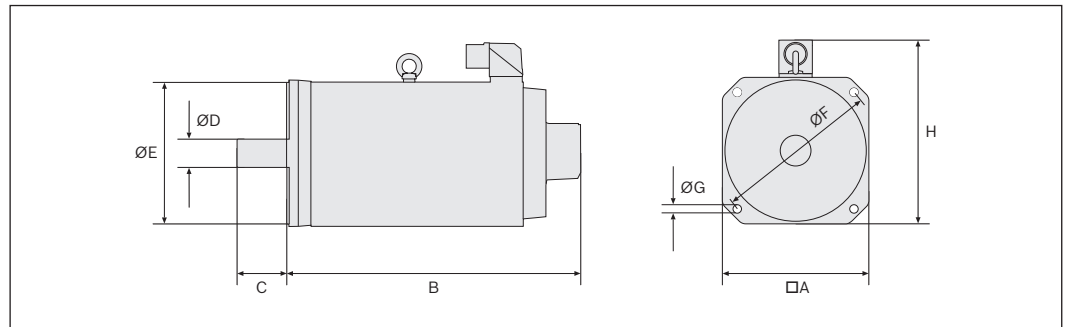
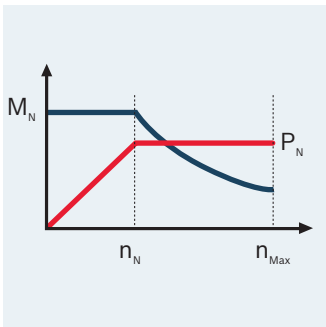

# IndraDyn L – MLF synchronous ironcore linear motors

Compact construction, high protection category and maximum forces of up to 21,500 N – these characteristics make the MLF synchronous linear motors well suited to meet the challenges posed by machine tools.

Given their low force ripple, the motors are particularly suitable for quickly transporting large masses in harsh environments. The motors are fully encapsulated in a stainless steel/titanium alloy sheet metal case, and they can be installed right in the machining area of machine tools.

There is a choice of sizes geared to typical requirements supplied in standard encapsulation or thermal encapsulation to minimize the heat that enters the machine. The combination of several linear motors – whether in series or parallel – gives rise to completely new machine concepts with greatly enhanced machining force.

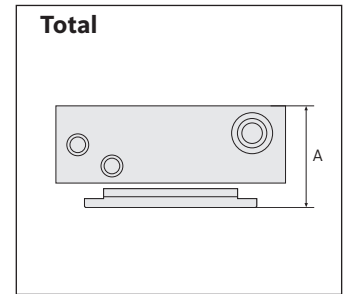
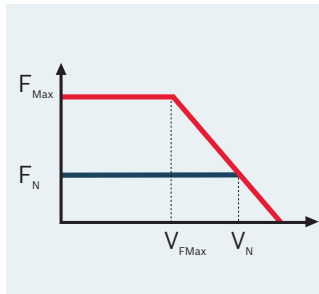

The simple step-by-step guide to ordering your IndraDyn L synchronous linear motor:

**MLP140C-0170-F S-N0CN-NNNN**

<b>Motor</b>		<b>Vibration severity grade</b>
		<b>S</b> = Standard encapsulation
		<b>T</b> = Thermal encapsulation

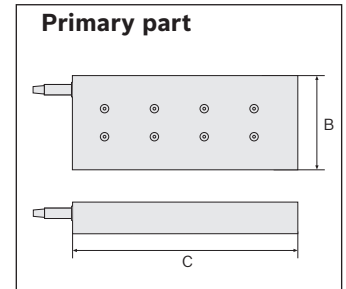

The simple step-by-step guide to ordering your IndraDyn L synchronous linear motor:

**MLS 140S-3A-150-NNNN**

<b>Motor</b>	<b>Segment length D</b>
► Size (e.g. “140”)	<b>0150</b> = 150 mm
	<b>0450</b> = 450 mm
	<b>0600</b> = 600 mm

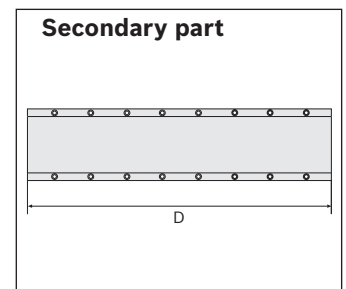

## High dynamics and precision

- ▶ Maximum force of up to 21,500 N
- ▶ Graduated nominal speeds of up to 500 m/min
- ▶ Compact dimensions
- ▶ Complete stainless steel encapsulation in IP65
- ▶ Heat dissipation minimized by liquid cooling



Motor		Continuous nominal force	Maximum force	Nominal speed	Maximum speed with F <sub>max</sub>	Continuous nominal current	Maximum current	Standard encapsulation			Thermal encapsulation				
											Primary part weight				Primary part weight
								F <sub>N</sub> N	F <sub>Max</sub> N	V <sub>N</sub> m/min	V <sub>FMax</sub> m/min	I <sub>N</sub> A	I <sub>Max</sub> A	A mm	B mm
MLP040	A-0300	250	800	500	300	3.8	18	61.4	100	210	4.7	73.9	108	235	6.1
	B-0150	370	1,150	300	150	3.9	18.7	61.4	100	285	6.1	73.9	108	310	8.1
	B-0250	370	1,150	400	250	5.6	28.3	61.4	100	285	6.1	73.9	108	310	8.1
	B-0300	370	1,150	500	300	6.3	36.9	61.4	100	285	6.1	73.9	108	310	8.1
MLP070	A-0150	550	2,000	200	150	4.5	29.6	61.4	130	285	8.4	73.9	138	310	10.9
	A-0220	550	2,000	360	220	6.1	40.5	61.4	130	285	8.4	73.9	138	310	10.9
	A-0300	550	2,000	450	300	8	42	61.4	130	285	8.4	73.9	138	310	10.9
	B-0100	820	2,600	200	100	4.6	23.6	61.4	130	360	10.4	73.9	138	385	13.4
	B-0120	820	2,600	220	120	5.9	42.8	61.4	130	360	10.4	73.9	138	385	13.4
	B-0150	820	2,600	260	150	7.3	56.8	61.4	130	360	10.4	73.9	138	385	13.4
	B-0250	820	2,600	400	250	10.4	57.1	61.4	130	360	10.4	73.9	138	385	13.4
	B-0300	820	2,600	450	300	11.6	67.7	61.4	130	360	10.4	73.9	138	385	13.4
	C-0120	1,200	3,800	180	120	9.2	56.9	61.4	130	510	14.5	73.9	138	535	18.4
	C-0150	1,200	3,800	250	150	11	65.9	61.4	130	510	14.5	73.9	138	535	18.4
	C-0240	1,200	3,800	350	240	15.6	107.9	61.4	130	510	14.5	73.9	138	535	18.4
	C-0300	1,200	3,800	450	300	18.4	106.7	61.4	130	510	14.5	73.9	138	535	18.4
MLP100	A-0090	1,180	3,750	150	90	5.9	34.2	61.4	160	360	13.5	73.9	168	385	17
	A-0120	1,180	3,750	190	120	7.4	40.5	61.4	160	360	13.5	73.9	168	385	17
	A-0150	1,180	3,750	220	150	9.2	50.8	61.4	160	360	13.5	73.9	168	385	17
	A-0190	1,180	3,750	290	190	11.9	69.2	61.4	160	360	13.5	73.9	168	385	17
	B-0120	1,785	5,600	190	120	12.2	71.2	61.4	160	510	18.7	73.9	168	535	23.3
	B-0250	1,785	5,600	350	250	24.1	142.6	61.4	160	510	18.7	73.9	168	535	23.3
	C-0090	2,310	7,150	170	90	12.1	83.6	61.4	160	660	24	73.9	168	685	29.7
	C-0120	2,310	7,150	190	120	15	84.9	61.4	160	660	24	73.9	168	685	29.7
	C-0190	2,310	7,150	290	190	24.2	147.1	61.4	160	660	24	73.9	168	685	29.7
	C-0300	2,310	7,150	450	300	47.1	231.1	61.4	200	660	32	73.9	208	685	38.9
MLP140	A-0120	1,680	5,200	190	120	12.1	70.8	61.4	200	360	17	73.9	208	385	21.2
	B-0090	2,415	7,650	160	90	14	79.3	61.4	200	510	24.5	73.9	208	535	30.1
	B-0120	2,415	7,650	190	120	17.8	103.8	61.4	200	510	24.5	73.9	208	535	30.1
	C-0050	3,150	10,000	110	50	14.6	78.6	61.4	200	660	32	73.9	208	685	38.9
	C-0120	3,150	10,000	190	120	20.7	122.9	61.4	200	660	32	73.9	208	685	38.9
	C-0170	3,150	10,000	250	170	28.5	137.8	61.4	200	660	32	73.9	208	685	38.9
MLP200	C-0350	3,150	10,000	400	350	47.1	231.1	61.4	200	660	32	73.9	208	685	38.9
	A-0090	2,415	7,450	170	90	12.9	69.6	61.4	260	360	23	73.9	268	385	28.3
	A-0120	2,415	7,450	190	120	14.8	81.3	61.4	260	360	23	73.9	268	385	28.3
	B-0040	3,465	10,900	100	40	13.8	74.2	61.4	260	510	33	73.9	268	535	40
	B-0120	3,465	10,900	190	120	21.8	128.6	61.4	260	510	33	73.9	268	535	40
	C-0090	4,460	14,250	170	90	22.9	117.9	61.4	260	660	42	73.9	268	685	50.7
	C-0120	4,460	14,250	190	120	28.4	165.6	61.4	260	660	42	73.9	268	685	50.7
	C-0170	4,460	14,250	220	170	35.6	162.6	61.4	260	660	42	73.9	268	685	50.7
	D-0060	5,560	17,750	140	60	25.2	126.2	61.4	260	810	51	73.9	268	835	61.3
	D-0100	5,560	17,750	180	100	44.8	204.4	61.4	260	810	51	73.9	268	835	61.3
D-0120	5,560	17,750	190	120	47.5	201.5	61.4	260	810	51	73.9	268	835	61.3	
MLP300	A-0090	3,350	11,000	160	90	17.2	99.3	-	-	-	-	87	368	385	40.8
	A-0120	3,350	11,000	190	120	21.6	129.9	-	-	-	-	87	368	385	40.8
	B-0070	5,150	16,300	140	70	28.4	141.9	-	-	-	-	87	368	535	58.3
	B-0120	5,150	16,300	190	120	38.2	223.5	-	-	-	-	87	368	535	58.3
	C-0060	6,720	21,500	110	60	29.6	143.1	-	-	-	-	87	368	685	74.9
	C-0090	6,720	21,500	150	90	35.8	205	-	-	-	-	87	368	685	74.9
	C-0120	6,720	21,500	180	120	45.2	300	-	-	-	-	87	368	685	74.9

All the specifications given are based on operation with liquid cooling and 540 V DC bus voltage.

# IndraDyn L – MCL synchronous ironless linear motors

Ironless MCL linear motors position small masses with superior precision and maximum synchronization. Compared to iron core motors, these motors distinguish themselves with the ironless design of the primary part, which contains the fully potted three-phase copper winding. The U-shaped secondary part contains permanent magnets and encloses the primary part. This design means that there is no attraction or cogging force between the primary and secondary part and the force constant is linear. These aspects, combined with the relatively small moving masses of the primary part, create a high level of dynamics with a very high degree of precision.

The compact design features different mounting planes on primary and secondary parts, providing the highest flexibility in construction design. Optionally, the linear motors also come with a Hall sensor unit to detect the position for the initial commutation.

Typical areas in which ironless linear motors can be used are applications where it is important to move small masses at the maximum possible cycle speed with extremely high precision. That includes pick-and-place machines used in the semiconductor segment as well as those used in general automation processes. The exceptionally smooth movement of the MCL motors also makes them perfect for use in measuring and testing machines.

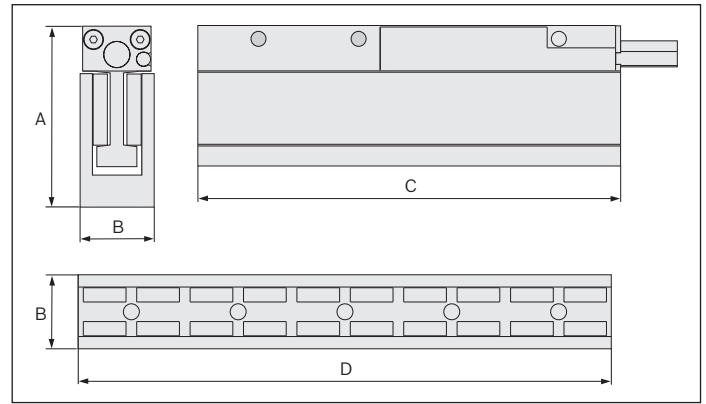
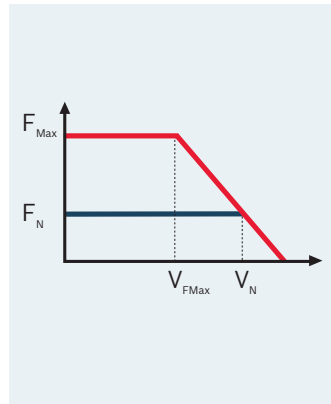

The simple step-by-step guide to ordering your IndraDyn L synchronous linear motor:

**MCP040C-V070-NI-N0CN-NNNN**

**Motor (primary part)**

- ▶ Size (e.g. "040")
- ▶ Overall length (e.g. "C")
- ▶ Winding (e.g. "070")

**Hall sensor**

- N0** = Without Hall sensor
- L0** = Digital Hall sensor<sup>1)</sup>
- L1** = Analog Hall sensor<sup>1)</sup>

**MCS040-3S-0120-NNNN**

**Motor (secondary part)**

- ▶ Size (e.g. "040")

**Segment length D**

- |                     |                      |
|---------------------|----------------------|
| For MCS015:         | <b>0120</b> = 120 mm |
| <b>0066</b> = 66 mm | <b>0180</b> = 180 mm |
| <b>0099</b> = 99 mm | <b>0300</b> = 300 mm |

<sup>1)</sup> Only for sizes MCP020-MCP070



## Linear motor without iron core

- ▶ Maximum force of up to 3,320 N
- ▶ Maximum speeds of up to 1,400 m/min
- ▶ Excellent synchronization, no cogging forces
- ▶ Low own weight, high acceleration and dynamics
- ▶ Simple integration thanks to various mounting planes



Type		Conti- nuous	Maximum	Nom.	Maximum speed	Rated current	Maximum	Dimensions			Primary
		nom. force	force	speed	speed	with Fmax	current				part
		$F_N$	$F_{Max}$	$V_N$	$V_{FMax}$	$I_N$	$I_{Max}$	A	B	C	m
		N	N	m/min	m/min	A	A	mm	mm	mm	kg
MCP015	A-L040	6	24	600	90	1.3	5.2	51	14.8	34	0.04
	B-L040	12	48	560	170	2.4	9.6	51	14.8	67	0.06
MCP020	B-V180	26	104	560	200	0.8	3.2	52	20.8	127	0.18
	B-V720	26	104	1,100	690	1.4	5.6	52	20.8	127	0.18
	C-V180	40	160	590	150	1.3	5.2	52	20.8	187	0.28
	C-V720	40	160	1,110	680	2.2	8.8	52	20.8	187	0.28
	D-V180	56	224	620	190	1.9	7.6	52	20.8	247	0.38
	D-V720	56	224	1,220	760	3.5	14	52	20.8	247	0.38
MCP030	B-V180	48	192	510	180	1.3	5.2	67	25	127	0.34
	B-V390	48	192	680	400	1.6	6.4	67	25	127	0.34
	C-V180	74	296	460	170	1.8	7.2	67	25	187	0.52
	C-V390	74	296	630	370	2.4	9.6	67	25	187	0.52
	D-V180	105	420	440	180	2.5	10	67	25	247	0.7
	D-V390	105	420	660	380	3.5	14	67	25	247	0.7
MCP040	B-V070	73	292	290	80	1.2	4.8	86.4	34.3	127	0.56
	B-V300	73	292	530	290	1.9	7.6	86.4	34.3	127	0.56
	C-V070	108	432	290	60	1.7	6.8	86.4	34.3	187	0.81
	C-V300	108	432	530	310	2.9	11.6	86.4	34.3	187	0.81
	E-V070	183	732	280	60	2.9	11.6	86.4	34.3	307	1.26
	E-V300	183	732	510	260	4.7	18.8	86.4	34.3	307	1.26
	G-V070	258	1,032	260	50	3.9	15.6	86.4	34.3	427	1.71
	G-V300	258	1,032	500	290	6.6	26.4	86.4	34.3	427	1.71
MCP070	C-V050	215	860	180	50	2.2	8.8	124	49.5	187	1.5
	C-V300	215	860	490	340	5.1	20.4	124	49.5	187	1.5
	D-V050	286	1,144	180	50	2.8	11.2	124	49.5	247	1.95
	D-V300	286	1,144	460	280	6.4	25.6	124	49.5	247	1.95
	F-V050	428	1,712	210	70	4.6	18.4	124	49.5	367	2.85
	F-V300	428	1,712	460	290	9.2	36.8	124	49.5	367	2.85
	M-V050	830	3,320	200	60	9	36	124	49.5	727	5.9
	M-V230	830	3,320	370	230	15.7	62.8	124	49.5	727	5.9

All the specifications given are based on operation with 300 V DC bus voltage (with 48 V for MCL015) and an optimum thermal connection.

# IndraDyn T – MBT synchronous torque motors

The IndraDyn T torque motors are liquid-cooled kit motors which have been optimized for high torques of up to 13,800 Nm. They consist of a stator with three-phase winding and a rotor with permanent magnets.

Typical areas of application for these motors mainly include direct drives in rotary tables or swivel axes in machining centers. However, they also offer innovative new approaches to solutions in mechanical engineering applications using robots, plastics processing machines, woodworking machines, lathes and special purpose machines.

The “cooling jacket” option on the MST stators consists of a closed-circuit cooling jacket, mounting flange and terminal box or plug. The rear side of the cooling jacket is open, and the rotor is attached to the machine shaft and mounting.

This solution features an optimal mix of standard solution and design freedom for the integration of direct-drive technology. Reduced design effort and service-friendly mounting offer substantial additional cost advantages.



The simple step-by-step guide to ordering your IndraDyn T torque motor:

**MST 530B-0070-FT-N0 CN-NNNN**

**Stator**

**Motor (stator)**

- ▶ Size (e.g. “530”)
- ▶ Overall length (e.g. “B”)
- ▶ Winding (e.g. “0070”)

**Liquid cooling system**

- FT** = Open cooling jacket
- FH** = Closed cooling jacket in housing, flange-mounted

**Electrical connection outlet**

- CN** = Axial on side with larger Ø
- SN** = Axial on side with smaller Ø
- RN<sup>1)</sup>** = Radial on side with larger Ø
- KR<sup>1)</sup>** = Terminal box
- PU<sup>1)</sup>** = Plug, turnable

<sup>1)</sup> Depending on motor size

The simple step-by-step guide to ordering your IndraDyn T torque motor:

**MRT 530B-3A-0410-NNNN**

**Rotor**

**Motor (rotor)**

- ▶ Size (e.g. “530”)
- ▶ Overall length (e.g. “B”)

**Internal diameter of rotor**

The rotors can be supplied with different internal diameters.

## Powerful and direct

- ▶ Maximum torques up to 13,800 Nm
- ▶ Full torque even at standstill
- ▶ Extremely high overload capacity
- ▶ Optionally available with flange housing
- ▶ Easy assembly

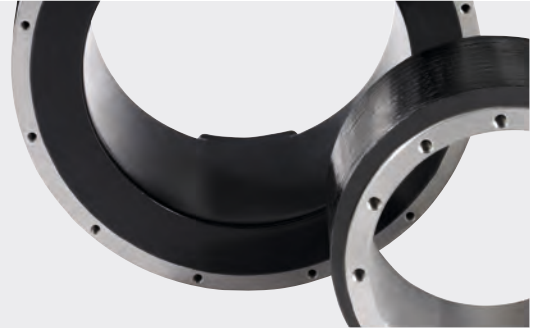

Motor		Rated torque	Maximum torque	Speed at $M_{max}$	Rated speed	Rated current	Maximum current	Moment of inertia (rotor) <sup>1)</sup>	Dimensions					Weight <sup>2)</sup>
		$M_N$	$M_{Max}$	$n_{MMax}$	$n_N$	$I_N$	$I_{Max}$	$J_R$	$\varnothing A$	B	$\varnothing C$	$\varnothing D$	E	m
		Nm	Nm	rpm	rpm	A	A	kgm <sup>2</sup>	mm	mm	mm	mm	mm	kg
MST130	A-0200	9	15	900	2,000	7.5	16	0.0008	150	63	60	-	-	2.4/0.65
	C-0050	25	40	225	500	7.5	12	0.0018	150	103	60	-	-	5.1/1.5
	C-0200	25	40	900	2,000	15.2	38	0.0018	150	103	60	-	-	5.1/1.5
	E-0020	42	65	90	200	7.5	12	0.0029	150	143	60	-	-	7.7/2.2
MST160	A-0050	35	90	180	500	6.5	20	0.0059	180	95	80	-	-	5.6/2.4
	C-0050	70	180	180	500	13	40	0.0108	180	145	80	-	-	9.6/4.3
	E-0050	105	270	180	500	19.5	60	0.0158	180	195	80	-	-	13.9/6.2
MST210	A-0027	50	100	100	270	7	25	0.012	230	75	120	260	140	7.2/3
	C-0027	120	250	100	270	13	50	0.023	230	120	120	260	185	11.5/4.8
	C-0050	120	250	200	500	25	100	0.023	230	120	120	260	185	11.5/4.8
	D-0070	150	300	270	700	32	120	0.027	230	150	120	260	215	13.8/5.8
	E-0027	240	500	100	270	24	90	0.042	230	195	120	260	260	18.8/7.8
MST290	B-0018	220	460	70	180	14.8	60	0.08	310	105	200	385	172	13.5/6.2
	D-0002	350	700	10	25	6.3	25	0.11	310	135	200	385	202	20/9
	D-0004	350	700	17	45	10.4	30	0.11	310	135	200	385	202	20/9
	D-0018	350	700	70	180	26	100	0.11	310	135	200	385	202	20/9
	E-0004	575	1,150	16	40	12.5	50	0.17	310	195	200	385	262	25.1/11.6
MST360	E-0018	575	1,150	70	180	35	125	0.17	310	195	200	385	262	25.1/11.6
	B-0006	375	760	145	60	8.8	20	0.19	385	120	260	450	195	23/9.8
	B-0018	375	900	70	180	20	70	0.19	385	120	260	450	195	23/9.8
	D-0009	525	1,150	180	90	12	31	0.27	385	150	260	450	225	28.8/13.5
	D-0012	525	1,150	45	120	16.5	60	0.27	385	150	260	450	225	28.8/13.5
MST450	D-0018	525	1,150	70	180	28	100	0.27	385	150	260	450	225	28.8/13.5
	E-0018	875	1,900	70	180	42	141	0.44	385	210	260	450	285	40.3/20.9
	B-0012	540	1,200	45	120	22	70	0.45	480	120	350	570	200	31/13
	D-0006	810	1,800	25	60	18.8	50	0.64	480	150	350	570	230	38.7/17.9
	D-0012	810	1,800	45	120	33	100	0.64	480	150	350	570	230	38.7/17.9
MST530	E-0006	1,400	3,250	25	60	32	88	1.01	480	210	350	570	290	54.2/27.7
	E-0012	1,400	3,250	45	120	46	125	1.01	480	210	350	570	290	54.2/27.7
	B-0010	800	1,800	45	100	28.6	71	0.92	565	120	410	645	200	36/22
	C-0010	1,200	2,700	40	100	31.2	88	1.25	565	150	410	645	230	45/27.5
	E-0010	2,100	4,700	40	100	64	212	1.92	565	210	410	645	290	63/38.5
MST530	G-0006	4,200	9,200	25	60	76	240	3.84	565	370	410	645	455	144/77
	G-0007	4,200	9,200	28	70	96	305	3.84	565	370	410	645	455	144/77
	G-0010	4,200	9,200	130	100	117	350	3.84	565	370	410	645	455	144/77
	L-0003	6,300	11,000	68	30	57.8	120	5.76	565	520	410	645	605	205/115
	L-0006	6,300	13,800	25	60	120	380	5.76	565	520	410	645	605	205/115
	L-0007	6,300	13,800	28	70	133	420	5.76	565	520	410	645	605	205/115

All the specifications given are based on operation with liquid cooling and 540 V DC bus voltage.

<sup>1)</sup> Depends on rotor version; <sup>2)</sup> Stator/rotor on open cooling jacket version

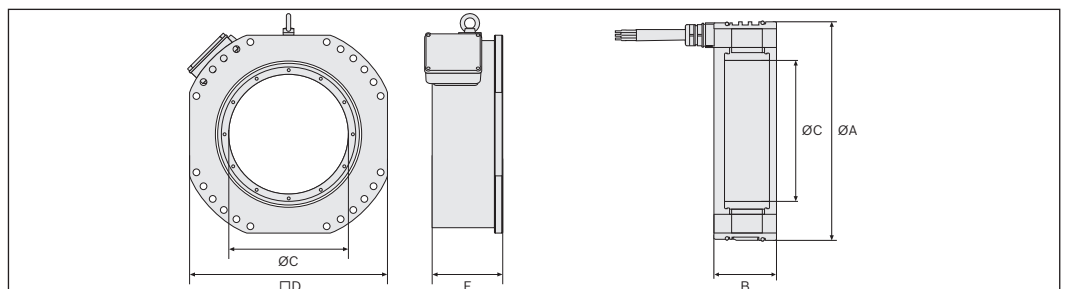
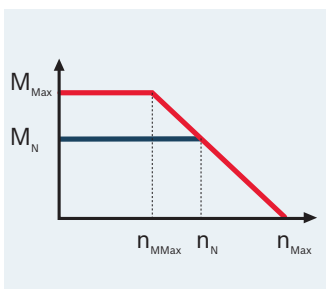

# IndraDyn H – MBS synchronous high-speed motors

The liquid-cooled high-speed IndraDyn H kit motors achieve maximum torques of up to 4,500 Nm with speeds of up to 30,000 rpm.

With their broad constant output power range, short ramp-up time and low rotor temperature they are predestined for motor spindles and other similar areas of application.

The new on board cooling system simplifies their integration in the machine and increases their cooling efficiency.

For extra easy assembly and disassembly we can supply the rotor on request with a step interference fit and the corresponding hydraulic connections.

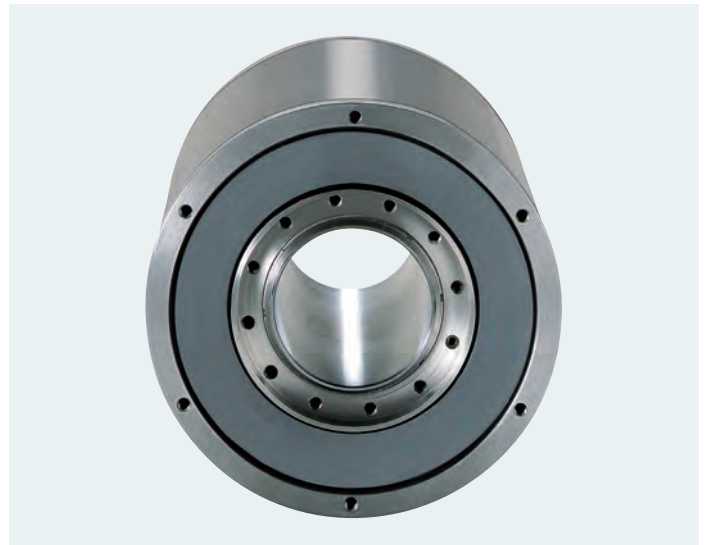

The simple step-by-step guide to ordering your high-speed IndraDyn H motor:

**MSS 182A-0100-FA-NOCN-NNNN**

**Stator**

**Motor (stator)**

- ▶ Size (e.g. "182")
- ▶ Overall length (e.g. "A")
- ▶ Winding (e.g. "0100")

The simple step-by-step guide to ordering your high-speed IndraDyn H motor:

**MRS 182A-1N-0075-NNNN**

**Rotor**

**Motor (primary part)**

- ▶ Size (e.g. "182")
- ▶ Overall length (e.g. "A")

**Internal diameter of rotor**

Corresponding internal diameters are available for every rotor size.  
For further details see motor manual.

**Rotor version**

- 1N** = Smooth bore
- 2N** = Step interference fit with hydraulic connection

## High dynamics and precision

- ▶ Maximum torques of up to 4,500 Nm
- ▶ Maximum speeds up to 22,500 rpm
- ▶ Wide constant output power range
- ▶ Integrated cooling system
- ▶ Easy integration into the machine

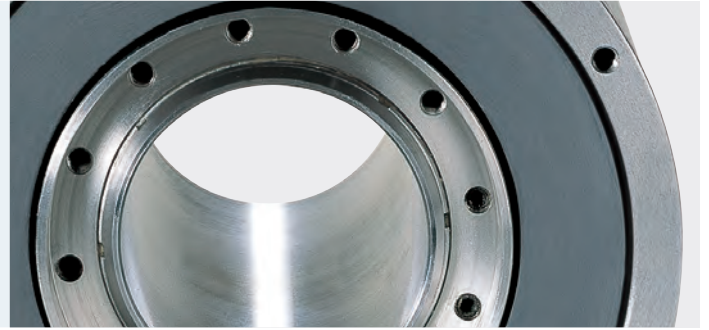

Type		Rated speed	Maximum speed	Rated torque	Maximum torque	Rated power	Rated current	Maximum current	Moment of inertia <sup>1)</sup>	Dimensions			Weight <sup>2)</sup>
		$n_N$ rpm	$n_{Max}$ rpm	$M_N$ Nm	$M_{Max}$ Nm	$P_N$ kW	$I_N$ A	$I_{Max}$ A	$J$ kgm <sup>2</sup>	$\varnothing A$ mm	B mm	$\varnothing C$ mm	m kg
MSS102	B-0800	8,000	22,500	10.7	36.7	8.96	16.9	52	0.003	120	156	46	5.8/2.1
	D-0800	8,000	22,500	20	45	16.8	24	69	0.004	120	206	46	7.2/3.1
	F-0300	3,000	18,000	32	75	10.1	15.3	35	0.006	120	306	46	11.2/5.1
	F-0800	8,000	22,500	26	68	21.8	43	100	0.006	120	306	46	11.2/5.1
MSS142	B-0700	7,000	19,000	27.5	67	20.2	45	100	0.011	160	181	58	9.6/4.2
	D-0700	7,000	19,000	40.5	90	29.7	65	140	0.014	160	231	58	16/6.5
	F-0700	7,000	19,000	53	113	38.9	84	180	0.017	160	281	58	21/8.3
MSS162	B-0400	4,000	16,500	50	115	20.9	42	110	0.014	180	206	68	22/6.9
	D-0400	4,000	16,500	70	160	29.3	64	170	0.018	180	256	68	28.1/8.8
	F-0310	3,100	15,500	90	200	29.2	64	170	0.022	180	306	68	28.2/10.6
	J-0200	2,000	10,000	120	275	25.1	50	130	0.028	180	381	68	46.1/13.4
MSS182	A-0100	1,000	6,000	12	30	1.25	3.7	11	0.009	200	82	85	6.9/2.7
	A-0250	2,500	12,000	12	30	3.1	5	15	0.009	200	82	85	6.9/2.7
	B-0280	2,800	12,000	100	230	29.3	64	170	0.031	200	232	85	32.1/9.6
	D-0260	2,600	12,000	140	320	38.1	71	200	0.039	200	282	85	38.9/11.8
MSS202	F-0200	2,000	12,000	200	450	41.9	71	200	0.053	200	382	85	43.5/16.3
	A-0200	2,000	11,000	105	270	22	45	130	0.05	220	215	96	25/12.8
	B-0150	1,500	8,200	141	353	22.2	46	128	0.064	220	265	96	40.7/16.2
	B-0210	2,100	11,500	128	320	28.1	52	144	0.064	220	265	96	40.7/16.2
	D-0170	1,700	9,300	163	407	29	53	147	0.077	220	315	96	37.6/19.6
	D-0360	3,600	12,500	136	333	51.3	102	197	0.077	-	315	-	37.6/19.6
MSS242	F-0120	1,200	6,600	194	484	24.3	45	125	0.104	220	415	96	63.7/26.9
	B-0100	1,000	6,000	250	575	26.2	68	180	0.119	270	275	110	66.7/22.5
	D-0070	700	4,200	375	860	27.5	49.5	180	0.167	270	375	110	92.3/31.7
MSS272	F-0060	600	3,600	425	970	26.7	68	180	0.193	270	425	110	105.1/36.5
	B-0065	650	3,000	400	900	27.2	71	200	0.268	300	330	135	90.4/35.5
	B-0080	800	3,200	400	900	33.5	82	250	0.268	300	330	135	90.4/35.5
	D-0050	500	2,200	525	1,200	27.5	71	200	0.335	300	405	135	112.3/44.5
	F-0040	400	1,800	650	1,500	27.2	71	200	0.403	300	465	135	134.2/53.5
MSS312	B-0035	350	1,500	650	1,550	23.8	62.5	170	0.617	340	380	170	128.7/55.0
	D-0028	280	1,200	820	1,950	24	59.5	160	0.751	340	455	170	154.1/67.4
	D-0060	600	2,400	820	1,950	51.5	93.2	250	0.751	340	455	170	154.1/67.4
	F-0028	280	1,200	975	2,275	28.6	62	180	0.885	340	530	170	179.5/79.5
	H-0025	250	1,100	1,125	2,750	29.5	62	180	1.064	340	630	170	215/95.6
	H-0085	850	3,400	1,100	2,750	97.9	197	570	1.064	340	630	170	215/95.6
MSS382	B-0025	250	1,000	1,375	2,875	36	85	250	1.525	405	430	240	178.5/77.6
	D-0020	200	800	1,775	3,700	37.2	101	250	1.911	405	530	240	242.7/97.2
	F-0018	180	720	2,170	4,500	40.9	83.6	250	2.296	405	630	240	262/116.8
MSS482	A-0200	2,000	4,000	120	275	25.1	40	210	0.604	510	115	345	59/16.2

All the specifications given are based on operation with liquid cooling and 540 V DC bus voltage. The indicated maximum speed is reached at a DC bus voltage of 750 V. <sup>1)</sup> Depends on rotor version; <sup>2)</sup> Stator/rotor with largest available internal diameter of rotor

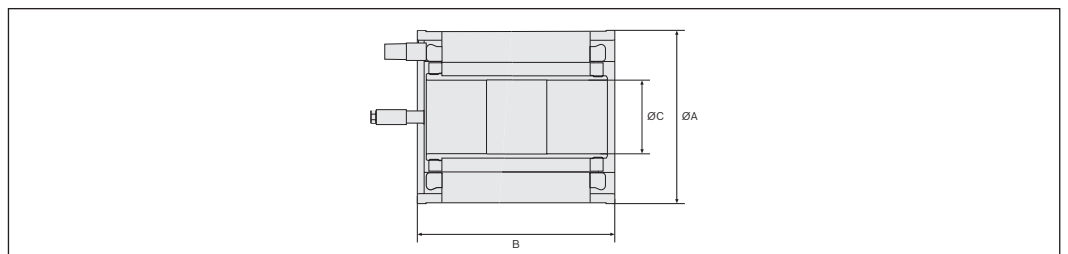
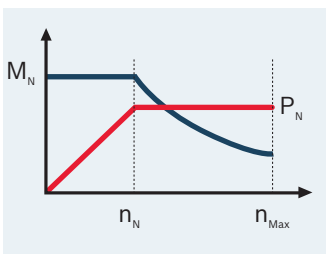

# 1 MB – asynchronous high-speed motors

The liquid-cooled 1MB high-speed motors are maintenance-free asynchronous motors with high power density. For different performance requirements and installation situations, our product range offers 8 motor sizes with different overall lengths and diameters.

Typical areas of application of these motors are the main spindles of modern CNC machines and machining centers. These high-speed motors excel by their superb running smoothness and perfect servo quality for C-axis machining, thread cutting and spindle positioning.

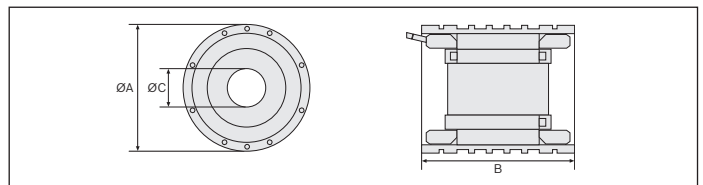

The simple step-by-step guide to ordering your asynchronous high-speed motor 1MB:

## 1MS 310B-6B-A2 / S010

### Stator

#### Motor (stator)

- ▶ Size (e.g. “310”)
- ▶ Overall length (e.g. “B”)
- ▶ Winding (e.g. “6B”)

#### Special version

**S010** = With several integrated temperature sensors (NTC thermistor, PTC thermistor, temperature switch)

#### Electrical connection

- 1** = Lines at the stator side brought out with larger outside diameter
- 2** = Lines at the stator side brought out with smaller outside diameter

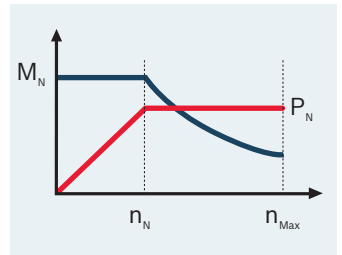

The simple step-by-step guide to ordering your asynchronous high-speed motor 1MB:

## 1MR 310B-A 094

### Rotor

#### Motor (primary part)

- ▶ Size (e.g. “310”)
- ▶ Overall length (e.g. “B”)

#### Internal diameter of rotor

For each rotor size, corresponding internal diameters are available. For further details see motor manual.

#### Rotor version

E.g. step interference with hydraulic connection

## Robust and reliable

- ▶ Rated torques up to 875 Nm
- ▶ Maximum speeds up to 20,000 rpm
- ▶ Large spindle cutoff
- ▶ Excellent running smoothness
- ▶ Easy integration into the machine



Motor		Rated speed	Maximum speed	Rated torque	Rated power	Rated current	Moment of inertia <sup>3)</sup>	Dimensions			Weight <sup>2)</sup>
		$n_N$ rpm	$n_{Max}$ rpm	$M_N$ Nm	$P_N$ kW	$I_N$ A	$J_R$ kgm <sup>2</sup>	$\varnothing A$ mm	B mm	$\varnothing C^{1)}$ mm	m kg
1MS105	N-4A	4,500	15,000	15	7	29	0.0033	120	350	40.5	11.2/2.8
	N-4B	2,400	12,000	22	5.5	16.4	0.0033	120	350	40.5	11.2/2.8
1MS140	B-4A	7,500	20,000	7	5.5	18	0.0044	160	150	45	5.3/3.3
	B-4B	5,000	20,000	7	3.7	25	0.0044	160	150	45	5.3/3.3
	D-4B	4,000	16,000	14	6	43	0.0061	160	190	45	8.2/4.5
	F-4A	3,000	15,000	24	7.5	43	0.0082	160	240	45	11.8/6.1
	H-4B	3,000	15,000	34	10.5	58	0.0103	160	290	45	15.5/7.3
	B-4A	3,000	12,000	16	5	36	0.0084	180	160	60	6.8/5.3
1MS160	D-4A	3,000	12,000	32	10	48	0.0121	180	205	60	11.1/7.3
	D-4B	2,000	8,000	32	6.7	23.8	0.0121	180	205	60	11.1/7.3
	E-4B	1,000	4,000	33	3.5	19	0.0149	180	240	60	14.4/9.4
	F-4A	3,000	12,000	48	15	74	0.0161	180	255	60	15.8/10.2
	F-4B	3,000	12,000	48	15	45	0.0161	180	255	60	15.8/10.2
	F-4D	2,500	10,000	48	12.5	23.2	0.0161	180	255	60	15.8/10.2
	H-4A	3,000	12,000	64	20	58	0.0201	180	310	60	21/9.8
	N-4A	3,000	12,000	89	28	75	0.0267	180	385	60	28.1/12.7
	N-4B	2,000	8,000	89	18.6	60	0.0267	180	385	60	28.1/12.7
	N-4C	1,500	6,000	89	14	26	0.0267	180	385	60	28.1/12.7
1MS200	C-4A	1,500	6,000	57	9	50	0.041	220	240	66	21/15
	D-4B	1,500	6,000	85	13.5	48	0.037	220	295	66	29/19
	D-4C	5,000	20,000	59	31	75	0.037	220	295	66	29/19
	D-4D	2,500	10,000	85	22	59	0.037	220	295	66	29/19
	D-4E	1,500	6,000	85	13.5	84	0.037	220	295	66	29/19
	D-4F	6,000	18,000	49	31	82	0.037	220	295	66	29/19
	E-4B	1,800	7,200	85	16	41.4	0.059	220	330	66	34/22
	E-4C	3,900	15,600	74	30.2	65	0.059	220	330	66	34/22
	H-4B	1,500	6,000	124	19.5	68	0.069	220	380	66	41/26
	H-4D	1,500	6,000	124	19.5	52.6	0.069	220	380	66	41/26
1MS240	B-4A	1,000	4,000	62	6.5	46	0.078	270	270	72	29/19
	F-4A	1,000	4,000	123	13	74	0.12	270	360	72	48/29
	H-4B	1,000	4,000	169	18	56	0.153	270	430	72	62/37
1MS241	D-6A	1,000	4,000	112	12	62	0.135	270	290	111	38/24
	D-6C	1,000	4,000	112	12	27	0.135	270	290	111	38/24
	H-6C	1,800	7,200	202	32	75.5	0.227	270	410	111	63/39
	H-6D	850	3,400	202	18	66.4	0.227	270	410	111	63/39
	H-6G	800	3,200	202	16.9	39.7	0.227	270	410	111	63/39
1MS242	N-4B	1,700	6,800	185	33	98	0.135	270	440	71	81/37
1MS270	C-4B	1,500	6,000	190	30	96	0.258	300	400	120	82/52
1MS310	B-6B	1,000	4,000	260	27	75	0.477	340	385	125	84/65
	B-6D	700	2,800	260	19	81	0.477	340	385	125	84/65
	B-6E	440	1,760	260	12	58	0.477	340	385	125	84/65
	D-6B	800	3,200	340	28.5	81	0.492	340	450	125	108/80
	F-6A	400	1,600	480	20	61	0.723	340	520	125	133/97
	F-6B	900	3,600	480	35	111	0.723	340	520	125	133/97
	B-6B	600	2,400	636	40	120	1.39	405	520	170	162/106
1MS375	D-6B	600	2,400	875	55	150	1.73	405	620	170	205/132
	D-6D	300	1,200	875	27.5	94	1.73	405	620	170	205/132

All the specifications given are based on operation with liquid cooling and 540 V DC bus voltage.

<sup>1)</sup> Available diameters depend on rotor version <sup>2)</sup> Stator/rotor <sup>3)</sup> Depending on the rotor version

# GTE – standard planetary gearboxes

Together with our dynamic MSK motors, the compact GTE range of planetary gearboxes guarantees high torques in all standard applications.

Typical areas of application include simple handling and automation systems with rack-and-pinion drives or synchronous belt drives.

Virtually all performance requirements can be met in these applications thanks to the subtle staggering of sizes and the high power density of the GTE gearboxes.

The single-stage or two-stage gearboxes can be supplied with a plain shaft or keyway.

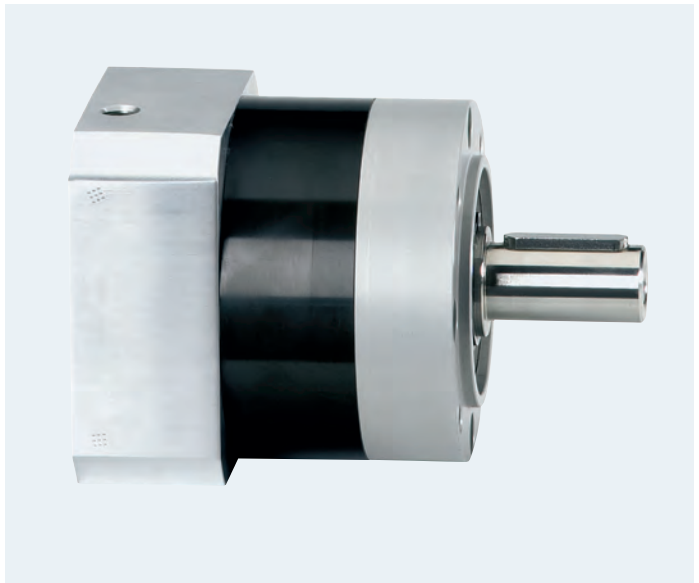

The simple step-by-step guide to ordering your GTE planetary gearboxes:

### GTE 060-NN 1-003 A-NN03

#### Gears

► Size (e.g. "040")

#### Gear range

**1** = Single-stage

**2** = Two-stage

#### Transmission ratio

**003** = Single-stage 3:1

**004** = Single-stage 4:1

**005** = Single-stage 5:1

**008** = Single-stage 8:1

**010** = Single-stage 10:1

**012** = Two-stage 12:1

**020** = Two-stage 20:1

**040** = Two-stage 40:1

#### Output shaft and backlash

**A** = With keyway

**B** = Plain shaft

<sup>1)</sup> Combination only possible with single-stage gearboxes

#### Motor/gearbox combination

Motor	GTE040	GTE060	GTE080	GTE120	GTE160	
MSK	030	–	NN02	NN02	–	
	040	–	–	NN03	NN03	
	043	–	–	NN03	NN03	
	050	–	–	–	NN20	NN20
	060	–	–	–	NN21 <sup>1)</sup>	NN21
	061	–	–	–	NN05 <sup>1)</sup>	NN05
	070	–	–	–	–	NN16
	071	–	–	–	–	NN16
	075	–	–	–	–	NN16
	076	–	–	–	–	NN06
100	–	–	–	–	NN09 <sup>1)</sup>	
KSM	041	–	–	NN03	NN03	
	061	–	–	–	NN05 <sup>1)</sup>	NN05
	071	–	–	–	–	NN16
	076	–	–	–	–	NN06
MSM	019A	NN45	–	–	–	
	019B	NN45	–	–	–	
	031B	–	NN42	–	–	
	031C	–	–	NN43	–	
	041B	–	–	NN44	NN44	



## Economical and compact

- ▶ Ideal for standard applications
- ▶ Low backlash
- ▶ Open choice of mounting positions
- ▶ Silent operation
- ▶ Lifetime lubrication



Gear	Transmission ratio	Maximum average input speed <sup>6)</sup>		Maximum input speed <sup>6)</sup>	Maximum output speed <sup>6)</sup>	Nominal input torque <sup>1) 3)</sup>	Nominal output torque <sup>1) 2) 3)</sup>	Maximum input torque	Maximum output torque <sup>1) 2) 3) 4)</sup>	Backlash	Torsion stiffness	Efficiency <sup>5)</sup>	Mass moment of inertia	Weight	
		at 50%	at 100%												
		$M_{OUT N}$	$M_{OUT N}$	$n_{IN Max}$	$n_{OUT Max}$	$M_{IN N}$	$M_{OUT N}$	$M_{IN Max}$	$M_{OUT Max}$	–	D	$\eta$	J	m	
Stage	i	rpm	rpm	rpm	rpm	Nm	Nm	Nm	Nm	arcmin	Nm/arcmin	%	kgcm <sup>2</sup>	kg	
GTE040	Single-stage	3	5,000	5,000	18,000	6,000	3.7	11	5.9	17.6	< 15	1	98	0.031	0.35
		4	5,000	5,000	18,000	4,500	3.8	15	6	24	< 15	1	98	0.022	0.35
		5	5,000	5,000	18,000	3,600	2.8	14	4.4	22	< 15	1	98	0.019	0.35
		8	5,000	5,000	18,000	2,250	0.8	6	1.25	10	< 15	1	96	0.017	0.35
		10	5,000	5,000	18,000	1,800	0.5	5	0.8	8	< 15	1	95	0.016	0.35
	Two-stage	12	5,000	5,000	18,000	1,500	1.7	20	2.7	32	< 19	1.1	96	0.029	0.45
GTE060	Single-stage	3	4,500	4,500	13,000	4,333	9.3	28	15	45	< 10	2.3	98	0.135	0.9
		4	4,500	4,500	13,000	3,250	9.5	38	15.25	61	< 10	2.3	98	0.093	0.9
		5	4,500	4,500	13,000	2,600	8	40	12.8	64	< 10	2.3	98	0.078	0.9
		8	4,500	4,500	13,000	1,625	2.3	18	3.63	29	< 10	2.3	97	0.065	0.9
		10	4,500	4,500	13,000	1,300	1.5	15	2.4	24	< 10	2.3	96	0.064	0.9
	Two-stage	12	4,500	4,500	13,000	1,083	3.7	44	5.83	70	< 12	2.5	96	0.127	1.1
GTE080	Single-stage	3	4,000	2,700	7,000	2,333	28.3	85	45.3	136	< 7	6	98	0.77	2.1
		4	3,850	2,500	7,000	1,750	28.8	115	46	184	< 7	6	98	0.52	2.1
		5	4,000	3,000	7,000	1,400	22	110	35.2	176	< 7	6	98	0.45	2.1
		8	4,000	4,000	7,000	875	6.3	50	10	80	< 7	6	97	0.39	2.1
		10	4,000	4,000	7,000	700	3.8	38	6.1	61	< 7	6	96	0.39	2.1
	Two-stage	12	4,000	3,750	7,000	583	10	120	16	192	< 9	6.5	97	0.72	2.6
GTE120	Single-stage	3	3,350	2,550	6,500	2,167	38.3	115	61.3	184	< 7	12	98	2.63	6
		4	3,400	2,500	6,500	1,625	38.8	155	62	248	< 7	12	98	1.79	6
		5	3,500	2,500	6,500	1,300	39	195	62.4	312	< 7	12	98	1.53	6
		8	3,500	3,500	6,500	813	15	120	24	192	< 7	12	97	1.32	6
		10	3,500	3,500	6,500	650	9.5	95	15.2	152	< 7	12	97	1.3	6
	Two-stage	12	3,500	2,650	6,500	542	21.7	260	34.7	416	< 9	13	96	2.56	8
GTE160	Single-stage	3	1,350	900	6,500	2,167	133.3	400	213.3	640	< 6	38	98	12.14	18
		4	1,450	1,000	6,500	1,625	112.5	450	180	720	< 6	38	98	7.78	18
		5	1,650	1,150	6,500	1,300	90	450	144	720	< 6	38	98	6.07	18
		8	2,150	1,550	6,500	813	56.3	450	90	720	< 6	38	97	4.63	18
		12	1,550	1,000	6,500	542	66.7	800	106.7	1,280	< 10	41	96	12.37	22
	Two-stage	20	2,050	1,400	6,500	325	40	800	64	1,280	< 10	41	96	6.65	22
40	2,950	2,300	6,500	163	17.5	700	28	1,120	< 10	41	94	5.28	22		

<sup>1)</sup> These values refer to an output shaft speed of 100 rpm on duty cycle KA = 1 as well as S1 mode for electrical machines and T = 30°C

<sup>2)</sup> Depends on the motor shaft diameter

<sup>3)</sup> With key, at tumescent load

<sup>4)</sup> Permissible for 30,000 output shaft revolutions

<sup>5)</sup> Depends on ratio, for output shaft speed = 100 rpm

<sup>6)</sup> Permissible operating temperature must be observed

# GTM – high-precision planetary gearboxes

Characterized by a particularly high power density and low backlash, the high-precision GTM range of planetary gearboxes has been designed for mounting directly on servo motors.

Their high degree of efficiency makes these gearboxes suitable for the S1 continuous operation and therefore ideal for use in printing presses, for example.

Combined with the dynamic IndraDyn motors they achieve the highest speeds, acceleration and optimum positioning accuracy.

The single-stage or two-stage gearboxes can be supplied with a plain shaft or keyway and also with reduced backlash on request.

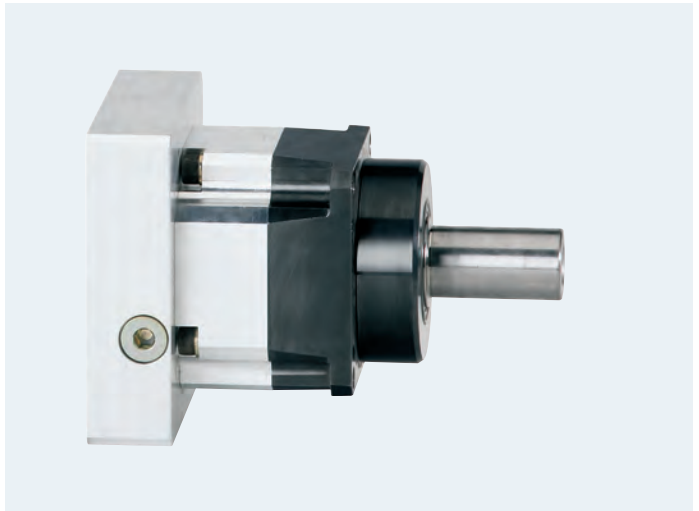

The simple step-by-step guide to ordering your GTM planetary gearbox:

### GTM 075-NN 1-004 A-NN03

#### Gears

► Size (e.g. “075”)

#### Gear range

**1** = Single-stage

**2** = Two-stage

#### Transmission ratio

**004** = Single-stage 4:1

**005** = Single-stage 5:1

**007** = Single-stage 7:1

**010** = Single-stage 10:1

**020** = Two-stage 20:1

**050** = Two-stage 50:1

#### Output shaft and backlash

**A** = With keyway

**B** = Plain shaft

**C** = Keyway and reduced backlash

**D** = Plain shaft and reduced backlash

<sup>1)</sup> Combination only possible with single-stage gearboxes

#### Motor/gearbox combination

Motor	GTM060	GTM075	GTM100	GTM140	GTM180	GTM240
MSK	030 NN02	-	-	-	-	-
	040 NN03	NN03	-	-	-	-
	043 NN03	NN03	-	-	-	-
	050 -	NN20	NN20	NN20	-	-
	060 -	NN21	NN21	NN21	-	-
	061 -	NN05	NN05	NN05	-	-
	070 -	-	NN16	NN16	NN16	-
	071 -	-	NN16	NN16	NN16	-
	075 -	-	NN16	NN16	NN16	-
	076 -	-	NN06	NN06	-	-
	100 -	-	-	NN09	NN09	-
	101 -	-	-	NN19	NN19	-
	103 -	-	-	NN19	NN19	-
KSM	131 -	-	-	-	NN15 <sup>1)</sup>	NN15 <sup>1)</sup>
	133 -	-	-	-	-	NN15 <sup>1)</sup>
	041 NN03	NN03	NN03	-	-	-
	061 -	NN05	NN05	NN05	-	-
	071 -	-	NN16	NN16	NN16	-
	076 -	-	NN06	NN06	-	-
MAD	100 -	-	-	NN09	NN09	-
	130 -	-	-	-	NN11 <sup>1)</sup>	NN11 <sup>1)</sup>
	160 -	-	-	-	-	NN12 <sup>1)</sup>
MAF	100 -	-	-	-	NN08	-
	130 -	-	-	-	NN11 <sup>1)</sup>	NN11 <sup>1)</sup>

## High precision and load capacity

- ▶ High-precision gearing for highest positioning accuracy
- ▶ Minimum power dissipation in continuous operation
- ▶ Optimized gear tooth forming for silent operation
- ▶ Environment-resistant, hermetically sealed housing
- ▶ High acceleration torque is achievable through a compact and rigid construction

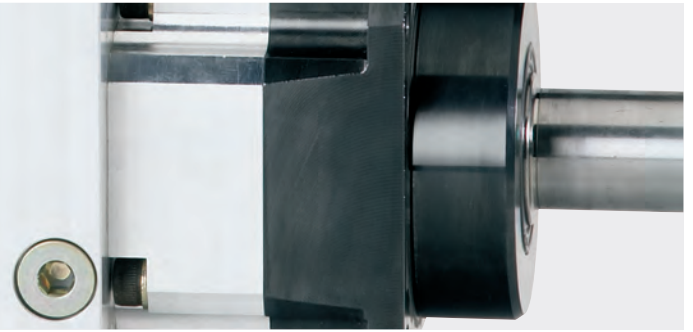

Gears	Transmission ratio	Nominal input speed	Maximum input speed	Maximum output speed	Nominal input torque	Nominal output torque	Maximum input torque	Maximum output torque	Backlash standard/reduced	Torsion stiffness	Efficiency	Moment of inertia	Weight	
		$n_{IN\ Nom}$	$n_{IN\ Max}$	$n_{OUT\ Max}$	$M_{IN\ Nom}$	$M_{OUT\ Nom}$	$M_{IN\ Max}$	$M_{OUT\ Max}$	-	D	$\eta$	J	m	
		rpm	rpm	rpm	Nm	Nm	Nm	Nm	arcmin	Nm/arcmin	%	kgcm <sup>2</sup>	kg	
GTM060	Single-stage	4	3,000	5,000	1,250	6.25	25	12.5	50	$\leq 6/\leq 3$	3.5	$\geq 97$	0.16	1.6
		5	4,000	6,300	1,260	5	25	10	50	$\leq 6/\leq 3$	3.5	$\geq 97$	0.16	1.6
		7	5,000	8,000	1,143	3.6	25	7.1	50	$\leq 6/\leq 3$	3.5	$\geq 97$	0.15	1.6
	Two-stage	10	6,000	10,000	1,000	2	20	4	40	$\leq 6/\leq 3$	3.5	$\geq 97$	0.14	1.6
		20	4,000	6,300	315	1.25	25	2.5	50	$\leq 8/\leq 6$	3.5	$\geq 94$	0.12	2.2
		50	6,000	10,000	200	0.5	25	1	50	$\leq 8/\leq 6$	3.5	$\geq 94$	0.1	2.2
GTM075	Single-stage	4	3,000	5,000	1,250	21.3	85	42.5	170	$\leq 6/\leq 3$	8.2	$\geq 97$	0.55	2.9
		5	4,000	6,300	1,260	20	100	40	200	$\leq 6/\leq 3$	8.2	$\geq 97$	0.47	2.9
		7	5,000	8,000	1,143	12.1	85	24.3	170	$\leq 6/\leq 3$	8.2	$\geq 97$	0.41	2.9
	Two-stage	10	6,000	10,000	1,000	6	60	11	110	$\leq 6/\leq 3$	8.2	$\geq 97$	0.38	2.9
		20	4,000	6,300	315	4.25	85	8.5	170	$\leq 8/\leq 6$	8.2	$\geq 94$	0.47	3.8
		50	6,000	10,000	200	2	100	4	200	$\leq 8/\leq 6$	8.2	$\geq 94$	0.47	3.8
GTM100	Single-stage	3	2,300	4,000	1,333	40	120	73.3	220	$\leq 4/\leq 2$	24	$\geq 97$	2.8	5.7
		4	2,500	4,000	1,000	42.5	170	85	340	$\leq 4/\leq 2$	24	$\geq 97$	2	5.7
		5	3,000	5,000	1,000	40	200	80	400	$\leq 4/\leq 2$	24	$\geq 97$	1.64	5.7
	Two-stage	7	4,000	6,300	900	24.3	170	48.6	340	$\leq 4/\leq 2$	24	$\geq 97$	1.36	5.7
		10	5,000	8,000	800	12	120	22	220	$\leq 4/\leq 2$	24	$\geq 97$	1.22	5.7
		20	3,000	5,000	250	8.5	170	17	340	$\leq 6/\leq 4$	24	$\geq 94$	1.56	7.5
GTM140	Single-stage	3	1,800	3,200	1,067	93.3	280	186.7	560	$\leq 4/\leq 2$	48	$\geq 97$	8.2	11.5
		4	2,000	3,200	800	105	420	210	840	$\leq 4/\leq 2$	48	$\geq 97$	6.75	11.5
		5	2,500	4,000	800	100	500	200	1,000	$\leq 4/\leq 2$	48	$\geq 97$	5.54	11.5
	Two-stage	7	3,000	5,000	714	60	420	120	840	$\leq 4/\leq 2$	48	$\geq 97$	4.59	11.5
		10	4,000	6,300	630	28	280	56	560	$\leq 4/\leq 2$	48	$\geq 97$	4.1	11.5
		20	2,500	4,000	200	21	420	42	840	$\leq 6/\leq 4$	48	$\geq 94$	5.29	15
GTM180	Single-stage	3	1,300	2,500	833	240	720	480	1,440	$\leq 4/\leq 2$	148	$\geq 97$	36	27
		4	1,500	2,500	625	255	1,020	510	2,040	$\leq 4/\leq 2$	148	$\geq 97$	24.5	27
		5	2,000	3,200	640	240	1,200	480	2,400	$\leq 4/\leq 2$	148	$\geq 97$	18.8	27
	Two-stage	7	2,500	4,000	571	145.7	1,020	291.4	2,040	$\leq 4/\leq 2$	148	$\geq 97$	14.5	27
		10	3,000	5,000	500	72	720	144	1,440	$\leq 4/\leq 2$	148	$\geq 97$	12.3	27
		20	2,000	3,200	160	51	1,020	102	2,040	$\leq 6/\leq 4$	148	$\geq 94$	6.95	35
GTM240	Single-stage	3	800	2,000	667	600	1,800	1,000	3,000	$\leq 4/\leq 2$	340	$\geq 97$	128	62
		4	1,000	2,000	500	625	2,500	1,250	5,000	$\leq 4/\leq 2$	340	$\geq 97$	97.6	62
		5	1,200	2,500	500	600	3,000	1,200	6,000	$\leq 4/\leq 2$	340	$\geq 97$	76.4	62
	Two-stage	7	1,500	3,000	429	357.1	2,500	714.3	5,000	$\leq 4/\leq 2$	340	$\geq 97$	59.9	62
		10	2,000	3,500	350	180	1,800	300	3,000	$\leq 4/\leq 2$	340	$\geq 97$	51.1	62

## Standard and geared motors – for simple applications

For use with frequency converters we recommend combining IndraDrive with geared motors or three-phase asynchronous motors made by NORD Drive Systems or VEM Motors.

Upon request we can supply all-in-one solutions, comprising of control units and motors also sourced directly from Rexroth.

Our range of geared motors covers various types of gears of different performance categories:

- ▶ Spur gear motors with rated outputs of up to 160 kW and torques of up to 26,000 Nm
- ▶ Offset geared motors with rated outputs of up to 200 kW and torques of up to 200,000 Nm
- ▶ Bevel gear motors with rated outputs of up to 160 kW and torques of up to 32,000 Nm
- ▶ Worm gear motors with rated outputs of up to 15 kW and torques of up to 3,000 Nm

- ▶ Our range of three-phase asynchronous motors includes:
- ▶ Standard motors with rated outputs of up to 500 kW
- ▶ Energy-saving motors with rated outputs of up to 335 kW

These motors are particularly suitable for operation with frequency converters and boast the following features:

- ▶ Motor design conforming to DIN EN 60034 (IEC 72)
- ▶ Mounting dimensions and output correlation compliant with DIN 42673, 42677
- ▶ Robust, low-vibration version in gray cast iron
- ▶ Protection category IP55, higher protection category up to IP65 optional
- ▶ Insulation class F with thermal reserve, insulation class H optional
- ▶ Further options include brakes, encoders, position of terminal box, etc.

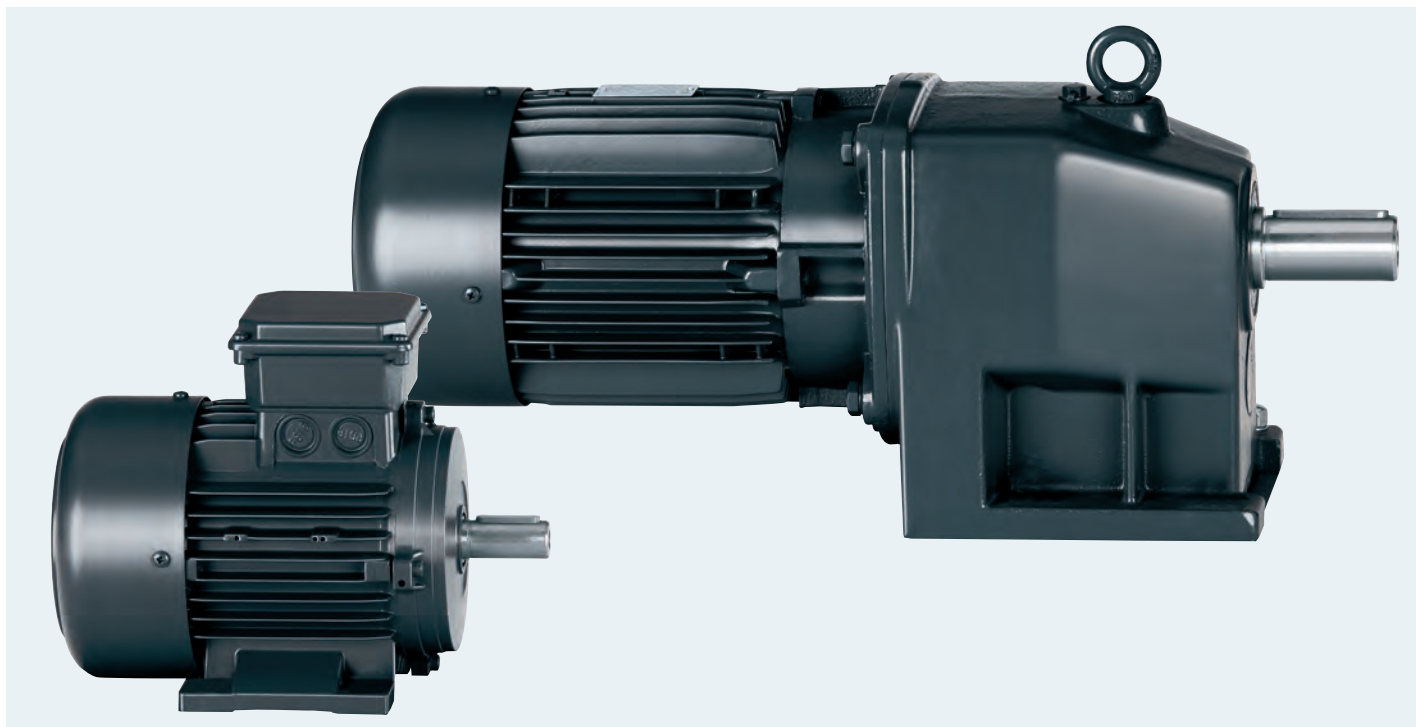

# Cross reference for IEC standard motors

Mechanical motor output $P_{Nom}$	$I_{Nom}$	$\cos \varphi$	$\eta$	Continous operation $I_{Nom}$ (>10 min)	Overload operation $1.1 \times I_{Nom}$ (1 min) $I_{Nom}$ (9 min)	Overload operation $1.5 \times I_{Nom}$ (1 min) $I_{Nom}$ (4 min)	Overload operation $2 \times I_{Nom}$ (2 s) $I_{Nom}$ (18 s)
1.1 kW	2.6 A	0.79	76.6%	HCS02.1E-W0012 HMS01.1N-W0020 HMD01.1N-W0012	HCS02.1E-W0012 HMS01.1N-W0020 HMD01.1N-W0012	HCS02.1E-W0012 HMS01.1N-W0020 HMD01.1N-W0012	HCS02.1E-W0012 HMS01.1N-W0020 HMD01.1N-W0012
1.5 kW	3.4 A	0.81	78.8%	HCS02.1E-W0012 HMS01.1N-W0020 HMD01.1N-W0012	HCS02.1E-W0012 HMS01.1N-W0020 HMD01.1N-W0012	HCS02.1E-W0028 HMS01.1N-W0020 HMD01.1N-W0012	HCS02.1E-W0028 HMS01.1N-W0020 HMD01.1N-W0012
2.2 kW	5.2 A	0.76	81%	HCS02.1E-W0028 HMS01.1N-W0020 HMD01.1N-W0012	HCS02.1E-W0028 HMS01.1N-W0020 HMD01.1N-W0012	HCS02.1E-W0028 HMS01.1N-W0020 HMD01.1N-W0012	HCS02.1E-W0028 HMS01.1N-W0020 HMD01.1N-W0012
3 kW	6.7 A	0.79	82%	HCS02.1E-W0028 HMS01.1N-W0020 HMD01.1N-W0012	HCS02.1E-W0028 HMS01.1N-W0020 HMD01.1N-W0020	HCS02.1E-W0028 HMS01.1N-W0020 HMD01.1N-W0020	HCS02.1E-W0028 HMS01.1N-W0020 HMD01.1N-W0020
4 kW	8.8 A	0.78	84.2%	HCS02.1E-W0028 HMS01.1N-W0020 HMD01.1N-W0020	HCS02.1E-W0028 HMS01.1N-W0020 HMD01.1N-W0020	HCS02.1E-W0028 HMS01.1N-W0036 HMD01.1N-W0036	HCS02.1E-W0054 <sup>1)</sup> HMS01.1N-W0036 HMD01.1N-W0036
5.5 kW	11.8 A	0.77	85.7%	HCS02.1E-W0054 <sup>1)</sup> HMS01.1N-W0020 HMD01.1N-W0036	HCS02.1E-W0054 <sup>1)</sup> HMS01.1N-W0036 HMD01.1N-W0036	HCS02.1E-W0054 <sup>1)</sup> HMS01.1N-W0036 HMD01.1N-W0036	HCS02.1E-W0054 <sup>1)</sup> HMS01.1N-W0036 HMD01.1N-W0036
7.5 kW	15 A	0.84	87%	HCS02.1E-W0054 <sup>1)</sup> HMS01.1N-W0036 HMD01.1N-W0036	HCS02.1E-W0054 <sup>1)</sup> HMS01.1N-W0036 HMD01.1N-W0036	HCS02.1E-W0070 <sup>1)</sup> HMS01.1N-W0036 HMD01.1N-W0036	HCS02.1E-W0070 <sup>1)</sup> HMS01.1N-W0036 HMD01.1N-W0036
11 kW	21 A	0.85	88.4%	HCS02.1E-W0070 <sup>1)</sup> HMS01.1N-W0036	HCS02.1E-W0070 <sup>1)</sup> HMS01.1N-W0054	HCS02.1E-W0070 <sup>1)</sup> HMS01.1N-W0054	HCS03.1E-W0070 <sup>1)</sup> HMS01.1N-W0054
15 kW	28 A	0.86	89.4%	HCS03.1E-W0070 <sup>1)</sup> HMS01.1N-W0054	HCS03.1E-W0070 <sup>1)</sup> HMS01.1N-W0054	HCS03.1E-W0070 <sup>1)</sup> HMS01.1N-W0070	HCS03.1E-W0070 <sup>1)</sup> HMS01.1N-W0070
18.5 kW	34.5 A	0.86	90%	HCS03.1E-W0070 <sup>1)</sup> HMS01.1N-W0054	HCS03.1E-W0070 <sup>1)</sup> HMS01.1N-W0070	HCS03.1E-W0100 <sup>1)</sup> HMS01.1N-W0110	HCS03.1E-W0100 <sup>1)</sup> HMS01.1N-W0110
22 kW	42 A	0.84	90.5%	HCS03.1E-W0070 <sup>1)</sup> HMS01.1N-W0070	HCS03.1E-W0100 <sup>1)</sup> HMS01.1N-W0110	HCS03.1E-W0100 <sup>1)</sup> HMS01.1N-W0110	HCS03.1E-W0100 <sup>1)</sup> HMS01.1N-W0110
30 kW	55.5 A	0.85	91.5%	HCS03.1E-W0100 <sup>1)</sup> HMS01.1N-W0110	HCS03.1E-W0100 <sup>1)</sup> HMS01.1N-W0110	HCS03.1E-W0150 <sup>1)</sup> HMS01.1N-W0150	HCS03.1E-W0150 <sup>1)</sup> HMS01.1N-W0150
37 kW	67 A	0.86	92.5%	HCS03.1E-W0100 <sup>1)</sup> HMS01.1N-W0110	HCS03.1E-W0150 <sup>1)</sup> HMS01.1N-W0150	HCS03.1E-W0150 <sup>1)</sup> HMS01.1N-W0150	HCS03.1E-W0150 <sup>1)</sup> HMS01.1N-W0150
45 kW	81 A	0.86	93%	HCS03.1E-W0150 <sup>1)</sup> HMS01.1N-W0150	HCS03.1E-W0150 <sup>1)</sup> HMS01.1N-W0150	HCS03.1E-W0210 <sup>1)</sup> HMS01.1N-W0210	HCS03.1E-W0210 <sup>1)</sup> HMS01.1N-W0210
55 kW	98.5 A	0.86	93.5%	HCS03.1E-W0210 <sup>1)</sup> HMS01.1N-W0150	HCS03.1E-W0210 <sup>1)</sup> HMS01.1N-W0210	HCS03.1E-W0210 <sup>1)</sup> HMS01.1N-W0210	HCS03.1E-W0210 <sup>1)</sup> HMS01.1N-W0210
75 kW	134 A	0.86	94.1%	HCS03.1E-W0210 <sup>1)</sup> HMS01.1N-W0210	HCS03.1E-W0210 <sup>1)</sup> HMS01.1N-W0210	HMS01.1N-W0350	HMS01.1N-W0350
90 kW	160 A	0.86	94.6%	HMS01.1N-W0350	HMS01.1N-W0350	HMS01.1N-W0350	HMS01.1N-W0350
110 kW	194 A	0.86	95.1%	HMS01.1N-W0350	HMS01.1N-W0350	–	–
132 kW	233 A	0.86	95.1%	HMS01.1N-W0350	HMS01.1N-W0350	–	–

The examples apply to the operation of 4-pole standard motors 3 AC 400 V/50 Hz at a 4 kHz switching frequency and a rotary frequency > 4 Hz. An external fan may be necessary depending on your application.

<sup>1)</sup> With HNL mains choke

# Cross reference for NEMA standard motors

Mechanical motor output $P_{Nom}$	$I_{Nom}$	$\cos \phi$	$\eta$	Continuous operation $I_{Nom}$ (>10 min)	Overload operation $1.1 \times I_{Nom}$ (1 min) $I_{Nom}$ (9 min)	Overload operation $1.5 \times I_{Nom}$ (1 min) $I_{Nom}$ (4 min)	Overload operation $2 \times I_{Nom}$ (2 s) $I_{Nom}$ (18 s)
1.5 hp	2.3 A	0.72	82.5%	HCS02.1E-W0012 HMS01.1N-W0020 HMD01.1N-W0012	HCS02.1E-W0012 HMS01.1N-W0020 HMD01.1N-W0012	HCS02.1E-W0012 HMS01.1N-W0020 HMD01.1N-W0012	HCS02.1E-W0012 HMS01.1N-W0020 HMD01.1N-W0012
2 hp	3.0 A	0.78	85.5%	HCS02.1E-W0012 HMS01.1N-W0020 HMD01.1N-W0012	HCS02.1E-W0012 HMS01.1N-W0020 HMD01.1N-W0012	HCS02.1E-W0012 HMS01.1N-W0020 HMD01.1N-W0012	HCS02.1E-W0012 HMS01.1N-W0020 HMD01.1N-W0012
3 hp	4 A	0.8	90.2%	HCS02.1E-W0028 HMS01.1N-W0020 HMD01.1N-W0012	HCS02.1E-W0028 HMS01.1N-W0020 HMD01.1N-W0012	HCS02.1E-W0028 HMS01.1N-W0020 HMD01.1N-W0012	HCS02.1E-W0028 HMS01.1N-W0020 HMD01.1N-W0012
5 hp	6.7 A	0.79	88.5%	HCS02.1E-W0028 HMS01.1N-W0020 HMD01.1N-W0012	HCS02.1E-W0028 HMS01.1N-W0020 HMD01.1N-W0020	HCS02.1E-W0028 HMS01.1N-W0020 HMD01.1N-W0020	HCS02.1E-W0028 HMS01.1N-W0020 HMD01.1N-W0020
7.5 hp	9.7 A	0.81	88.5%	HCS02.1E-W0054 <sup>1)</sup> HMS01.1N-W0020 HMD01.1N-W0020	HCS02.1E-W0054 <sup>1)</sup> HMS01.1N-W0020 HMD01.1N-W0036	HCS02.1E-W0054 <sup>1)</sup> HMS01.1N-W0036 HMD01.1N-W0036	HCS02.1E-W0054 <sup>1)</sup> HMS01.1N-W0036 HMD01.1N-W0036
10 hp	12.7 A	0.81	90.2%	HCS02.1E-W0054 <sup>1)</sup> HMS01.1N-W0036 HMD01.1N-W0036	HCS02.1E-W0054 <sup>1)</sup> HMS01.1N-W0036 HMD01.1N-W0036	HCS02.1E-W0054 <sup>1)</sup> HMS01.1N-W0036 HMD01.1N-W0036	HCS02.1E-W0054 <sup>1)</sup> HMS01.1N-W0036 HMD01.1N-W0036
15 hp	18.5 A	0.84	90.2%	HCS02.1E-W0070 <sup>1)</sup> HMS01.1N-W0036 HMD01.1N-W0036	HCS02.1E-W0070 <sup>1)</sup> HMS01.1N-W0036 HMD01.1N-W0036	HCS02.1E-W0070 <sup>1)</sup> HMS01.1N-W0054 -	HCS02.1E-W0070 <sup>1)</sup> HMS01.1N-W0054 -
20 hp	26 A	0.78	91%	HCS03.1E-W0070 <sup>1)</sup> HMS01.1N-W0054	HCS03.1E-W0070 <sup>1)</sup> HMS01.1N-W0054	HCS03.1E-W0070 <sup>1)</sup> HMS01.1N-W0054	HCS03.1E-W0070 <sup>1)</sup> HMS01.1N-W0054
25 hp	31.5 A	0.82	91.7%	HCS03.1E-W0070 <sup>1)</sup> HMS01.1N-W0054	HCS03.1E-W0070 <sup>1)</sup> HMS01.1N-W0054	HCS03.1E-W0100 <sup>1)</sup> HMS01.1N-W0110	HCS03.1E-W0070 <sup>1)</sup> HMS01.1N-W0110
30 hp	38.5 A	0.79	93%	HCS03.1E-W0070 <sup>1)</sup> HMS01.1N-W0070	HCS03.1E-W0070 <sup>1)</sup> HMS01.1N-W0070	HCS03.1E-W0100 <sup>1)</sup> HMS01.1N-W0110	HCS03.1E-W0100 <sup>1)</sup> HMS01.1N-W0110
40 hp	50 A	0.82	91.7%	HCS03.1E-W0100 <sup>1)</sup> HMS01.1N-W0110	HCS03.1E-W0100 <sup>1)</sup> HMS01.1N-W0110	HCS03.1E-W0100 <sup>1)</sup> HMS01.1N-W0150	HCS03.1E-W0150 <sup>1)</sup> HMS01.1N-W0150
50 hp	60.5 A	0.81	92.4%	HCS03.1E-W0100 <sup>1)</sup> HMS01.1N-W0110	HCS03.1E-W0100 <sup>1)</sup> HMS01.1N-W0110	HCS03.1E-W0150 <sup>1)</sup> HMS01.1N-W0150	HCS03.1E-W0150 <sup>1)</sup> HMS01.1N-W0150
60 hp	73.5 A	0.83	91.7%	HCS03.1E-W0150 <sup>1)</sup> HMS01.1N-W0150	HCS03.1E-W0150 <sup>1)</sup> HMS01.1N-W0150	HCS03.1E-W0210 <sup>1)</sup> HMS01.1N-W0210	HCS03.1E-W0210 <sup>1)</sup> HMS01.1N-W0210
75 hp	92 A	0.82	94.1%	HCS03.1E-W0150 <sup>1)</sup> HMS01.1N-W0150	HCS03.1E-W0210 <sup>1)</sup> HMS01.1N-W0150	HCS03.1E-W0210 <sup>1)</sup> HMS01.1N-W0210	HCS03.1E-W0210 <sup>1)</sup> HMS01.1N-W0210
100 hp	115 A	0.87	94.5%	HCS03.1E-W0210 <sup>1)</sup> HMS01.1N-W0210	HCS03.1E-W0210 <sup>1)</sup> HMS01.1N-W0210	HMS01.1N-W0350	HMS01.1N-W0350
125 hp	143 A	0.87	94.5%	HMS01.1N-W0210	HMS01.1N-W0350	HMS01.1N-W0350	HMS01.1N-W0350
150 hp	170 A	0.87	95.4%	HMS01.1N-W0350	HMS01.1N-W0350	HMS01.1N-W0350	HMS01.1N-W0350
200 hp	230 A	0.86	95%	HMS01.1N-W0350	HMS01.1N-W0350	-	-

The examples apply to the operation of 4-pole standard motors 3 AC 460 V/60 Hz at a 4 kHz switching frequency and a rotary frequency > 4 Hz. An external fan may be necessary depending on your application.

<sup>1)</sup> With HNL mains choke

# Cross references for motors on the HCS04 inverter

Mechanical motor output $P_{Nom}$	$I_{Nom}$	$\cos \varphi$	$\eta$	Overload operation $1.2 \times I_{Nom}$ (1 min) $I_{Nom}$ (9 min)	Overload operation $1.35 \times I_{Nom}$ (2 s) $I_{Nom}$ (28 s)	Overload operation $1.5 \times I_{Nom}$ (1 min) $I_{Nom}$ (9 min)	Overload operation $1.65 \times I_{Nom}$ (2 s) $I_{Nom}$ (28 s)
110 kW 150 hp	204 A	0.85	95%	HCS04.2E-W0350	HCS04.2E-W0350	HCS04.2E-W0350	HCS04.2E-W0350
132 kW 200 hp	246 A	0.85	95%	HCS04.2E-W0350	HCS04.2E-W0350	HCS04.2E-W0420	HCS04.2E-W0420
160 kW 250 hp	300 A	0.86	96%	HCS04.2E-W0420	HCS04.2E-W0420	HCS04.2E-W0520	HCS04.2E-W0520
200 kW 300 hp	366 A	0.87	96%	HCS04.2E-W0520	HCS04.2E-W0520	HCS04.2E-W0640	HCS04.2E-W0640
250 kW 400 hp	459 A	0.87	96%	HCS04.2E-W0640	HCS04.2E-W0640	HCS04.2E-W0790	HCS04.2E-W0790
315 kW 500 hp	586 A	0.87	96%	HCS04.2E-W0790	HCS04.2E-W0790	HCS04.2E-W1010	HCS04.2E-W1010
400 kW 600 hp	720 A	0.87	96%	HCS04.2E-W1010	HCS04.2E-W1010	HCS04.2E-W1240	HCS04.2E-W1240
500 kW 700 hp	894 A	0.88	97%	HCS04.2E-W1240	HCS04.2E-W1240	HCS04.2E-W1540	HCS04.2E-W1540
630 kW 900 hp	1126 A	0.88	97%	HCS04.2E-W1540	HCS04.2E-W1540		

The examples apply to the operation of 4-pole standard motors at a 4 kHz switching frequency and a rotary frequency > 4 Hz. The power data in kW apply to a voltage of 3 AC 400 V/50 Hz and the power data in hp apply to a voltage of 3 AC 460 V/60 Hz. Either a mains choke or a DC choke is required when operating an HCS04 inverter.

# Auxiliary components





## Accessories for all requirements

- ▶ Filters and chokes for EMC-proof operation
- ▶ Components designed to absorb high braking forces
- ▶ Energy storage capacitors for dynamic sequences
- ▶ Accessories for simplified assembly and installation

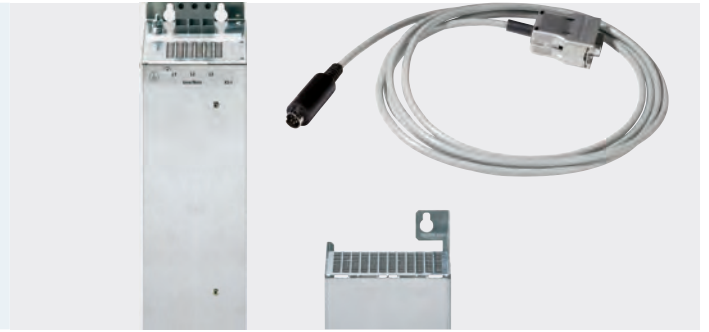

### Mains filters

#### Mains filters with integrated mains choke

#### Mains chokes

#### DC chokes

#### Motor filters

#### Brake choppers

#### Brake resistors

#### Brake units

#### Capacity modules

#### Blower unit

### Other accessories

- ▶ Basic accessories for assembly and installation
- ▶ Shield connection for EMC-compatible connection of the motor cable to the power unit
- ▶ Control cabinet adapter for combining control units of different depths
- ▶ Auxiliary capacitor
- ▶ Electrical adaptors
- ▶ Flange assembly kit
- ▶ Control cabinet assembly kit
- ▶ Modular bus extension to bridge larger distances between drive groups



# Mains filters – for HMV power supply units and HCS converters

Mains filters ensure that the EMC limit values are adhered to and suppress leakage current generated by line capacitors. Our mains filters are optimally coordinated with the power units and are scalable in regards to current, number of drives and motor cable length. They can be combined with our shielded motor cables for trouble-free operation conforming to EN 61800-3, Category C3, Second environment, even with single cable lengths of up to 75 m.

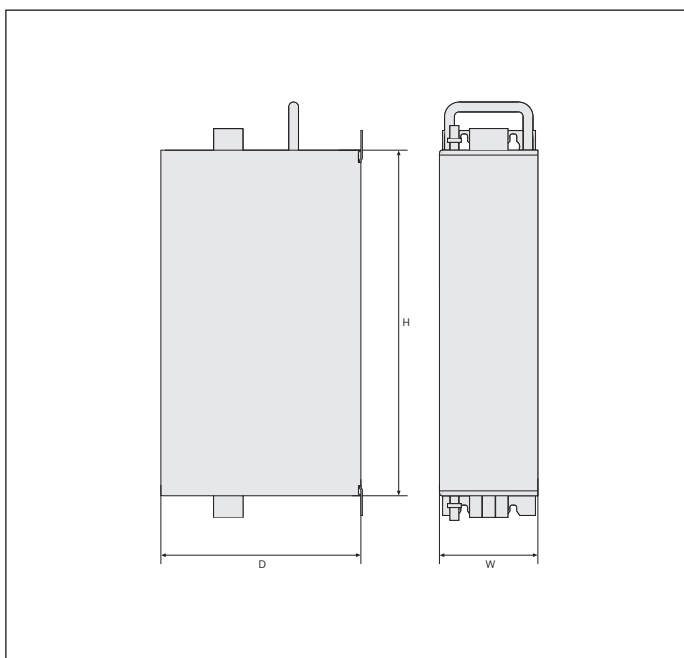

Mains filters for HMV power supply units and HCS converters	Continuous current	Power dissipation	Width W	Height H	Depth D	Weight
	A	W	mm	mm	mm	kg
HNF01.1A-F240-E0051-A-480-NNNN	51	< 89	100	440	262	15
HNF01.1A-M900-E0051-A-480-NNNN	51	< 91	100	440	262	15
HNF01.1A-F240-E0125-A-480-NNNN	125	< 127	150	440	262	18
HNF01.1A-M900-E0125-A-480-NNNN	125	< 174	150	440	262	30
HNF01.1A-F240-E0202-A-480-NNNN	202	< 238	150	440	262	29
HNF01.1A-M900-E0202-A-480-NNNN	202	< 373	250	440	262	37
HNF01.1A-F240-R0026-A-480-NNNN	26	< 73	100	440	262	14
HNF01.1A-M900-R0026-A-480-NNNN	26	< 77	150	440	262	17
HNF01.1A-F240-R0065-A-480-NNNN	65	< 163	150	440	262	25
HNF01.1A-M900-R0065-A-480-NNNN	65	< 157	150	440	262	26
HNF01.1A-F240-R0094-A-480-NNNN	94	< 135	150	440	262	28
HNF01.1A-M900-R0094-A-480-NNNN	94	< 146	150	440	262	29
HNF01.1A-H350-R0180-A-480-NNNN	180	< 305	250	440	262	45
HNS02.1A-Q200-R0023-A-480-NNNN	23	< 75	80	352	265	15
HNF01.1B-A100-E0300-N-480-NNNN	300	60	260	306	135	13
HNF01.1B-A100-E0580-N-480-NNNN	580	125	260	306	135	15
HNF01.1B-A100-E0740-N-480-NNNN	740	210	280	356	170	25
<b>For HCS converters</b>						
NFD03.1-480-007	7	3.9	50	160	90	0.7
NFD03.1-480-016	16	6.4	55	220	90	1
NFD03.1-480-030	30	11.9	60	270	100	1.4
NFD03.1-480-055	55	25.9	90	220	105	2
NFD03.1-480-075	75	30.4	90	240	145	3.5
NFD03.1-480-130	130	38	100	240	160	4.7
NFD03.1-480-180	180	61	130	350	180	10

All data apply to nominal rating at 3 AC 400 V mains voltage. Please see the selection tables on the end of this chapter for exact assignments to the power units.

# Mains filters with integrated mains choke – for HCS03 converters

The combination of mains filter and mains choke in one unit simplifies assembly and installation. It is simply fitted underneath the converter to form one space-saving unit. It is also a particularly easy way to comply with the directives contained in EN 61800-3, Category C3, Second environment.

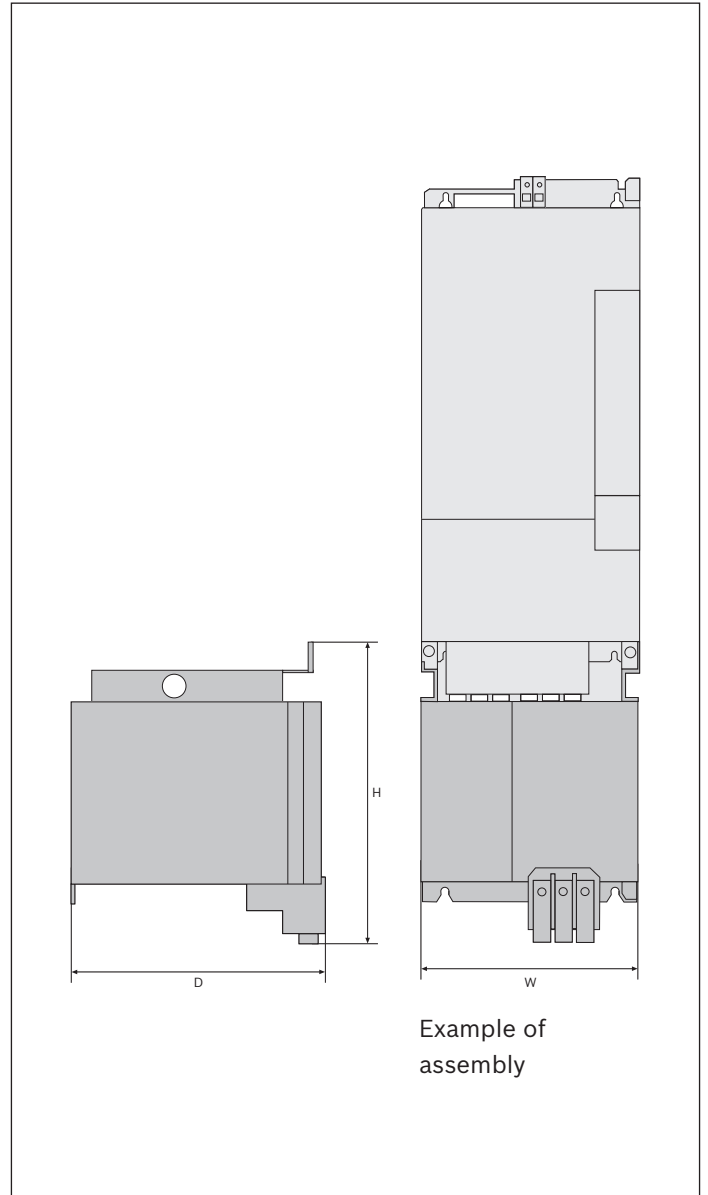

Mains filters with integrated mains choke	Continuous current	Power dissipation	Nominal inductance	Capacitance	Width W	Height H	Depth D	Weight
	A	W	μH	μF	mm	mm	mm	kg
HNK01.1A-A075-E0050-A-500-NNNN	50	55	3 x 571	3 x 1.1	125	322.5	251.5	15
HNK01.1A-A075-E0080-A-500-NNNN	80	80	3 x 362	3 x 2.2	225	310	270	20
HNK01.1A-A075-E0106-A-500-NNNN	106	110	3 x 240	3 x 2.2	225	310	270	20
HNK01.1A-A075-E0146-A-500-NNNN	146	130	3 x 170	3 x 2.2	350	380	270	28

All data apply to nominal rating at 3 AC 400 V mains voltage. Please see the selection tables on the end of this chapter for exact assignments to the power units.

# Mains chokes – for HMM power supply units and HCS converters

In connection with the mains chokes, converters and infeed power supply units realize higher DC bus continuous power. They reduce the harmonics in the line current while simultaneously preventing circuit feedback. When using supply units with line regeneration, these components are always required. This combination always complies to the permissible EMC values for industrial networks stipulated by EN 61000-2-4.

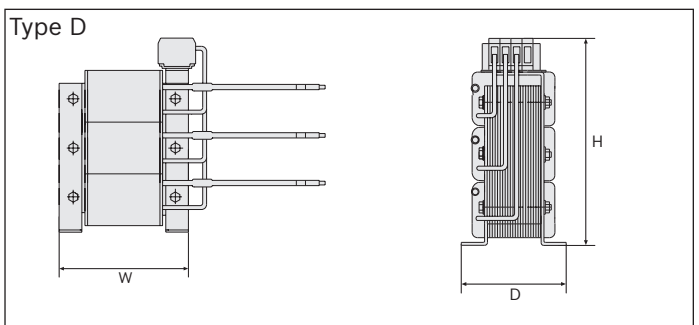
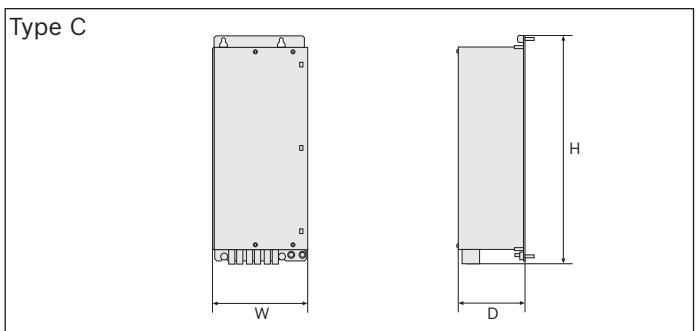
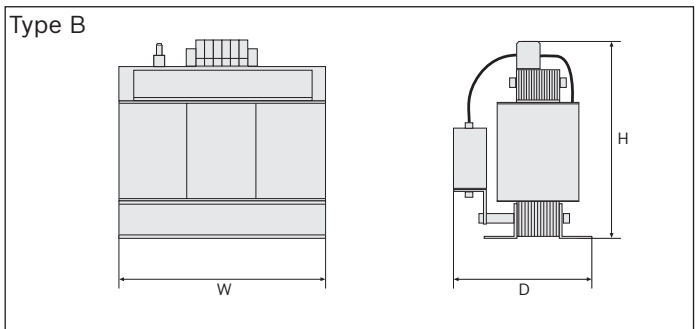
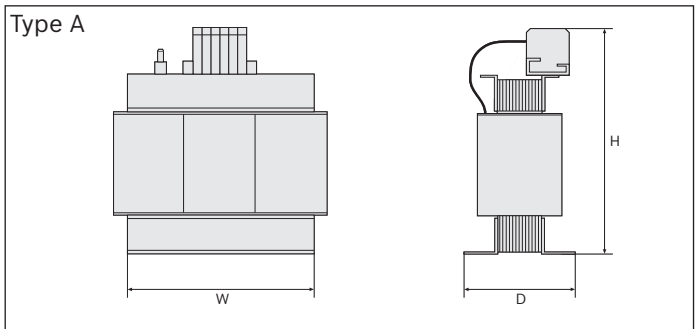

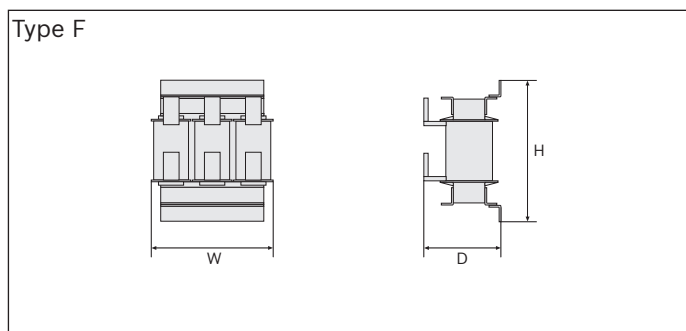
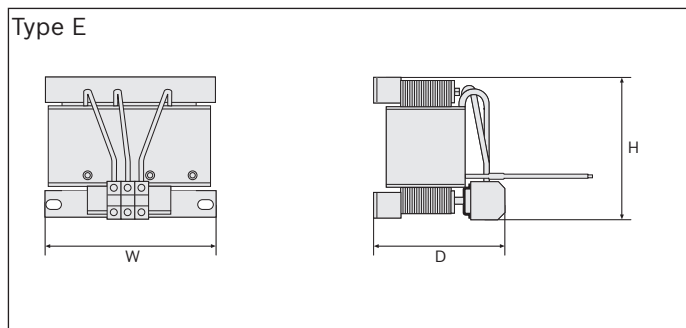

Mains choke	Continuous current	Power dissipation	Nominal inductance	Capacitance	Type	Width W	Height H	Depth D	Weight
	A	W	$\mu\text{H}$	$\mu\text{F}$		mm	mm	mm	kg
HNL01.1E-1000-N0012-A-500-NNNN	12	40	3 x 1,000	–	A	120	164	61	2.7
HNL01.1E-1000-N0020-A-500-NNNN	20	60	3 x 1,000	–	A	150	184	66.5	3.8
HNL01.1E-0600-N0032-A-500-NNNN	32	75	3 x 600	–	A	150	184	66.5	4.5
HNL01.1E-0400-N0051-A-480-NNNN	51	165	3 x 400	–	A	180	225	112	13.5
HNL01.1E-0200-N0125-A-480-NNNN	125	170	3 x 200	–	A	230	295	148	24
HNL01.1E-0100-N0202-A-480-NNNN	202	200	3 x 100	–	A	265	350	152	33
HNL01.1R-0980-C0026-A-480-NNNN	26	225	3 x 980	3 x 10	B	210	245	172	16
HNL01.1R-0590-C0065-A-480-NNNN	65	310	3 x 590	3 x 20	B	300	360	205	45
HNL01.1R-0540-C0094-A-480-NNNN	94	420	3 x 540	3 x 20	B	340	385	229	65
HNL01.1R-0300-C0180-A-480-NNNN	180	800	3 x 300	3 x 30	B	340	400	261	73
HNL02.1R-0980-C0023-A-480-NNNN <sup>1)</sup>	23	95	3 x 980	3 x 10	C	165	352	115	14
HNL01.1E-0571-N0050-A-500-NNNN	50	50	3 x 571	–	D	183	238	100	13
HNL01.1E-0362-N0080-A-500-NNNN	80	80	3 x 362	–	E	205	175	180	17
HNL01.1E-0240-N0106-A-500-NNNN	106	100	3 x 240	–	E	205	193	210	17
HNL01.1E-0170-N0146-A-500-NNNN	146	130	3 x 170	–	E	250	205	230	23
HNL01.1E-0098-N0280-N-690-NNNN	280	260	3 x 98	–	F	320	210	380	40
HNL01.1E-0085-N0315-N-690-NNNN	315	280	3 x 85	–	F	320	210	380	46
HNL01.1E-0066-N0365-N-690-NNNN	365	280	3 x 66	–	F	320	250	380	43
HNL01.1E-0060-N0475-N-690-NNNN	475	320	3 x 60	–	F	320	250	380	70
HNL01.1E-0038-N0650-N-690-NNNN	650	320	3 x 55	–	F	360	250	440	55
HNL01.1E-0032-N0760-N-690-NNNN	760	450	3 x 60	–	F	385	275	440	60
HNL01.1E-0038-N0540-N-690-NNNN	540	320	3 x 55	–	F	320	250	380	55
HNL01.1E-0026-N0620-N-690-NNNN	620	320	3 x 60	–	F	320	250	380	60

All data apply to nominal rating at 3 AC 400 V mains voltage. Please see the selection tables on the end of this chapter for exact assignments to the power units.

<sup>1)</sup> With integrated fan, supply voltage DC 24 V

# DC chokes – for HCS04 converters

HCS04 converters used with HLL DC chokes achieve higher continuous power in the DC bus.

They reduce the harmonics in the line current while simultaneously preventing circuit feedback.

These chokes are always required when the HCS04 converters are used in residential areas.

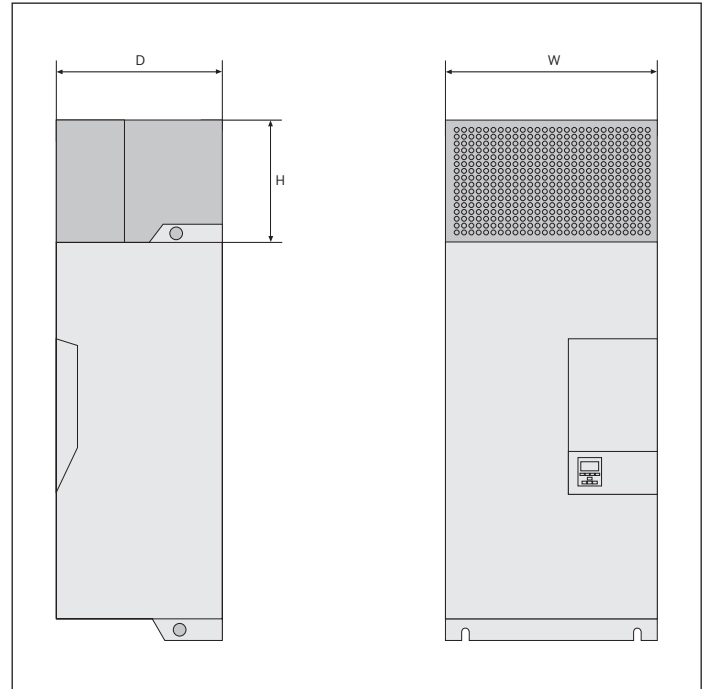

Motor filters	Continuous current	Power dissipation	Nominal inductance	Width W	Height H	Depth D	Weight
	A	W	μH	mm	mm	mm	kg
HLL01.1A-150U-N0290-C-008-0471-NNNN	290	210	150	360	240	377	32
HLL01.1A-138U-N0558-C-008-0558-NNNN	351	270	138	340	240	377	36
HLL01.1A-105U-N0486-C-008-0760-NNNN	574	345	105	440	240	377	53
HLL01.1A-095U-N0574-C-008-0840-NNNN	702	390	95	595	240	377	67
HLL01.1A-069U-N0702-C-008-1116-NNNN	702	495	69	595	240	377	67
HLL01.1A-063U-N0861-C-008-1260-NNNN	861	625	63	890	240	377	105
HLL01.1A-037U-N1160-C-008-1884-NNNN	1,160	700	37.5	890	240	377	115
HLL01.1A-034U-N1404-C-008-2232-NNNN	1,404	920	34.5	1,120	240	377	135

All data apply to nominal rating at 3 AC 400 V mains voltage.

Please see the selection tables on the end of this chapter for exact assignments to the power units.

# Motor filters – for HCS converters

The combination of the steep switching curves of modern converters and long motor wires can often cause transient overvoltages on the motor terminals. This, along with the leakage current of the motor wires, can be reduced by using a motor filter on the inverter output.

This provides the following advantages:

- ▶ Voltage rise limited to values below 1 kV/μs
- ▶ Winding insulation protected by limiting the voltage peak to max. 1,000 V
- ▶ Operation of several motors connected in parallel on one frequency converter via long supply lines
- ▶ Compliance with increased EMC requirements thanks to reduced interference voltages

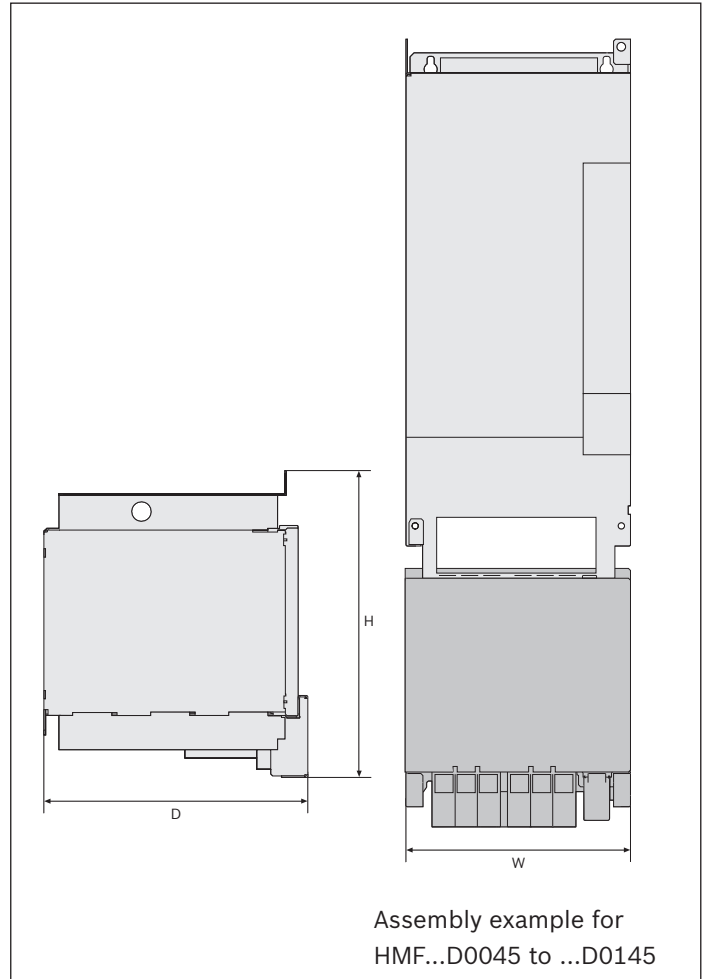

Motor filters	Continuous current	Power dissipation	Inductance	Width W	Height H	Depth D	Weight
	A	W	μH	mm	mm	mm	kg
HMF01.1N-N0K2-M0012-A-500-NNNN	12	25	3 x 900	155	162	92	5
HMF01.1N-N0K2-M0028-A-500-NNNN	28	50	3 x 450	210	182	130	11
HMF01.1A-N0K2-D0045-A-500-NNNN	45	120	3 x 160	125	330	270	15
HMF01.1A-N0K2-D0073-A-500-NNNN	72	160	3 x 100	225	315	270	15
HMF01.1A-N0K2-D0095-A-500-NNNN	95	190	3 x 78	225	315	270	20
HMF01.1A-N0K2-D0145-A-500-NNNN	145	220	3 x 50	350	400	260	20
HMF01.1N-N0K1-M0320-N-690-NNNN	314	475	in prep.	110	210	250	32
HMF01.1N-N0K1-M0480-N-690-NNNN	530	530	in prep.	200	245	250	58
HMF01.1N-N0K1-M0760-N-690-NNNN	759	600	in prep.	210	315	250	93
HMF01.1N-N0K1-M1190-N-690-NNNN	1,188	680	in prep.	230	370	250	120

All data apply to nominal rating at 3 AC 400 V mains voltage.

Please see the selection tables on the end of this chapter for exact assignments to the power units.

# Brake choppers – for HCS04 converters

Brake choppers are used together with an external braking resistor to increase the braking power.

The HLT brake chopper is controlled and monitored by the HCS04 converter.

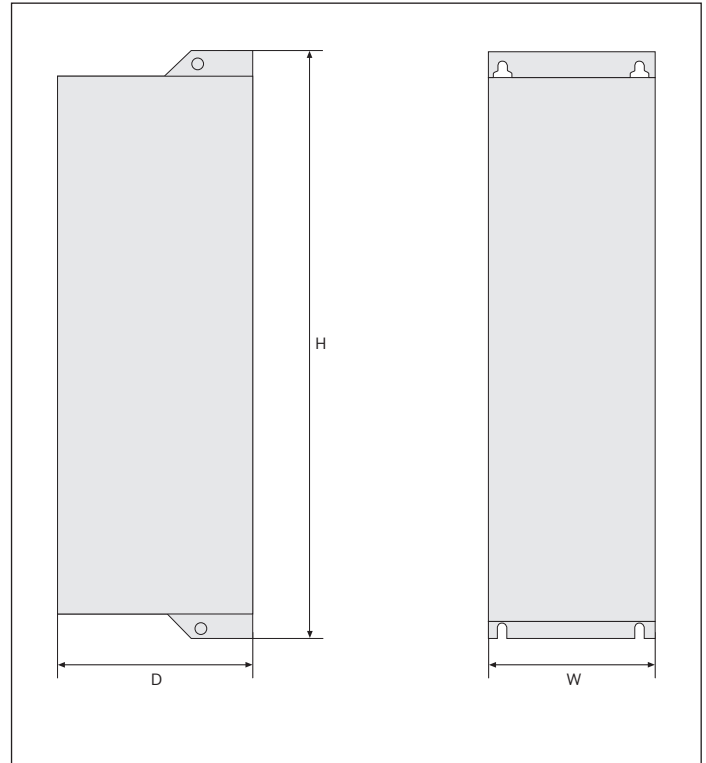

Brake choppers	Braking power				Power dissipation W	Width W mm	Height H mm	Depth D mm	Weight kg
	Duration	Max.	$t_{\text{on time}}$	$t_{\text{cycle time}}$					
			kW	kW					
HLT01.1A-200K-N-007-NNNN	200	420	12	240	550	70	950	377	30
HLT01.1A-400K-N-007-NNNN	400	750	12	240	1,050	310	1,150	377	70

Please see the selection tables on the end of this chapter for exact assignments to the power units.



# Brake resistors – for HCS converters

When using the HCS03 converters in regenerative operation there is a choice of particularly compact brake resistors for various different levels of power consumption.

The brake resistor is mounted directly above the converter.

This space-saving arrangement also simplifies the installation work. At the same time the converter's extracted air flow makes an effective cooling system.

The robust construction and high dielectric strength of the resistor elements enables high power and impulse loading.

The resistor elements are flameproof and are protected from harmful environmental factors by their full encapsulation.

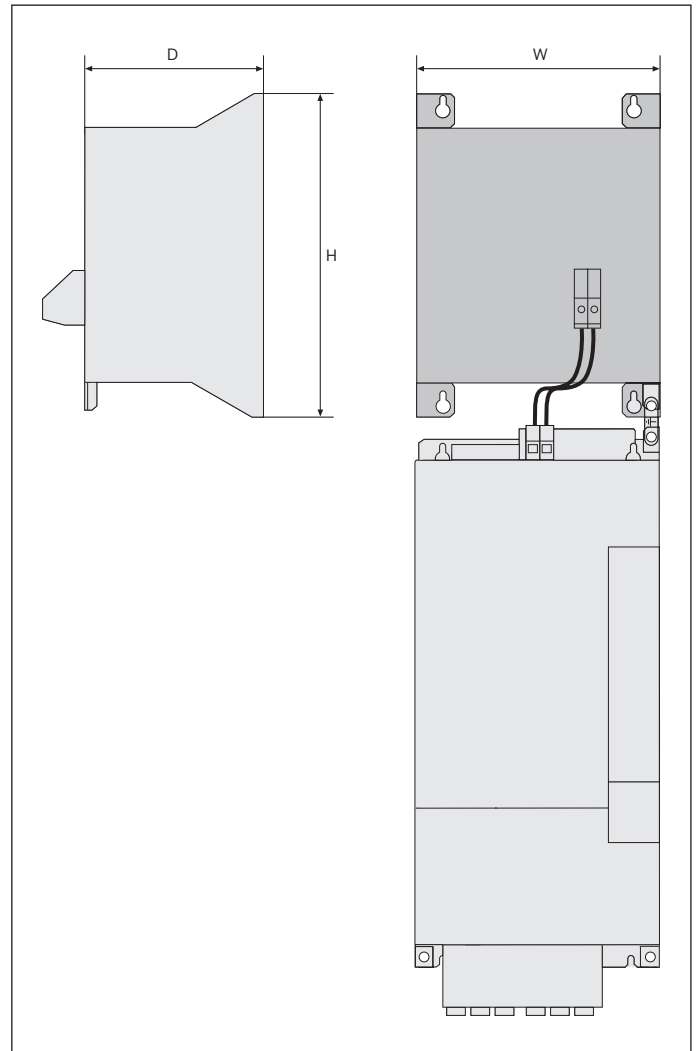

Brake resistor	Maximum energy consumption	Braking power				Resistance	Width W	Height H	Depth D	Weight
		Duration	Max.	t <sub>on time</sub>	t <sub>cycle time</sub>					
Ω	mm	mm	mm	kg						
HLR01.1N-0300-N17R5-A-007-NNNN	37	0.3	37	1	120	20.5	123	300	196	3
HLR01.1N-0470-N11R7-A-007-NNNN	56	0.47	56	1	120	13.7	223	300	210	4.5
HLR01.1N-0780-N07R0-A-007-NNNN	93	0.78	93	1	120	8.2	223	300	210	5.5
HLR01.1N-1K08-N05R0-A-007-NNNN	130	1.08	130	1	120	5.8	350	300	220	8
HLR01.1N-22k0-N03R5-B-007-NNNN	1,400	22	176	8	120	3.5	995	520	490	61
HLR01.1N-44k0-N03R3-B-007-NNNN	3,550	44	187	19	120	3.3	995	770	490	101
HLR01.1N-66k0-N02R1-B-007-NNNN	5,250	66	293	18	120	2.1	995	1,100	490	138

Please see the selection tables on the end of this chapter for exact assignments to the power units.

# Brake resistors – for HCS converters in heavy-duty version

The heavy-duty version of the brake resistor must always be used in applications where high regeneration occurs over a relatively long period of time. This is the case, for example, when lowering large loads or when braking high mass moments of inertia.

Depending on the braking power required there is a choice of compact brake resistors of different power levels and designs for each converter.

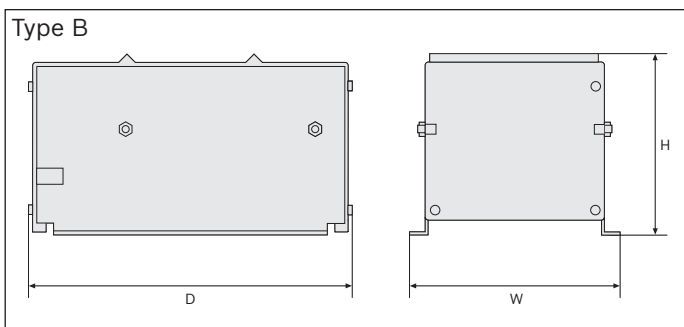
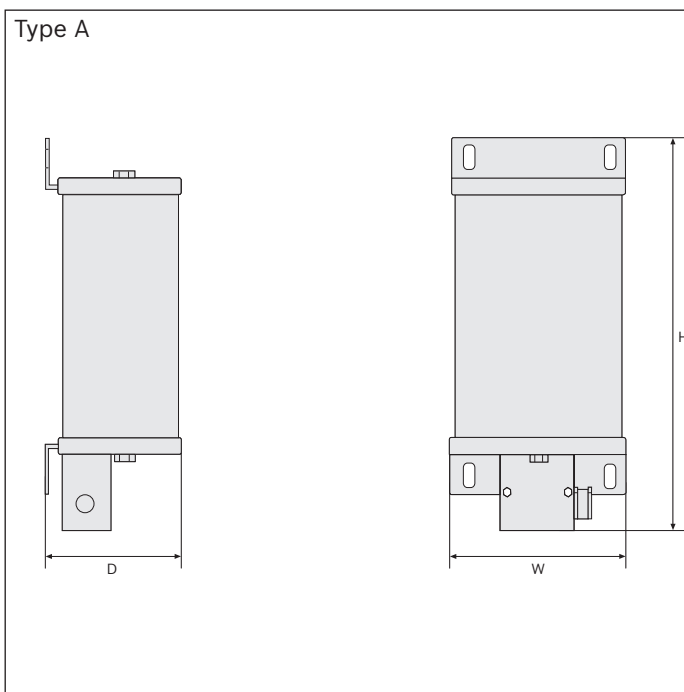

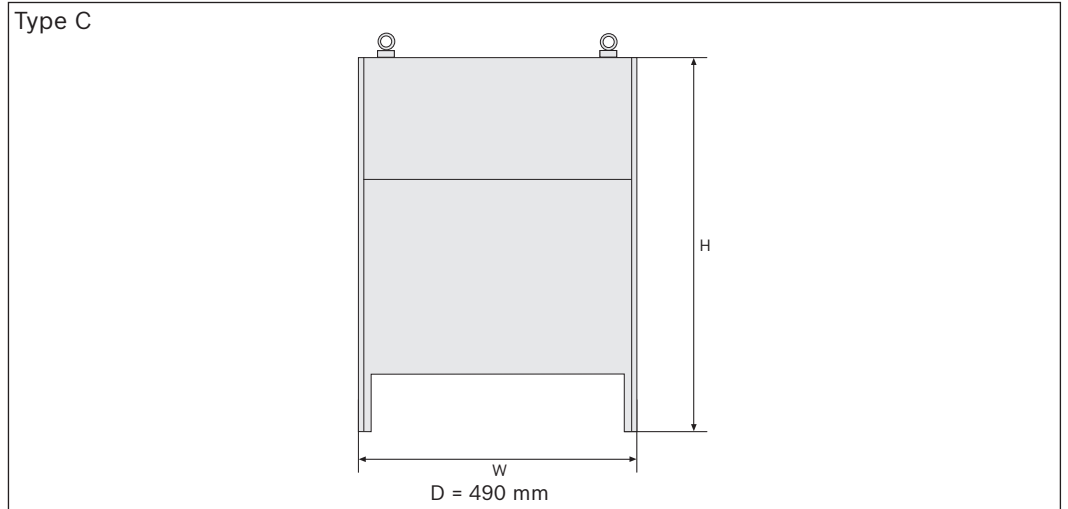
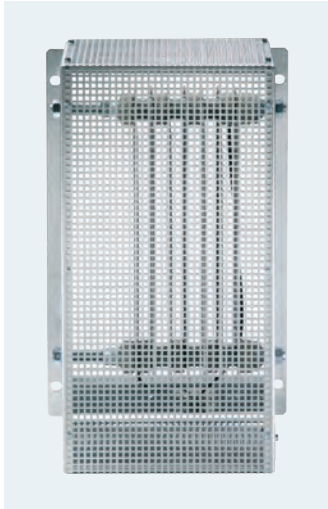

Brake resistor	Maximum energy consumption	Braking power				Resistance	Type	Width W	Height H	Depth D	Weight
		Duration	Max.	t <sub>on time</sub>	t <sub>cycle time</sub>						
HLR01.1N-01K8-N40R0-A-007-NNNN	72	1.8	18	4	120	40	A	275	549	120	6.6
HLR01.1N-03K8-N40R3-A-007-NNNN	300	3.8	18	16.7	120	40.3	B	490	270	300	9.5
HLR01.1N-02K4-N28R0-A-007-NNNN	100	2.4	26	3.9	120	28	A	275	649	120	7.9
HLR01.1N-05K5-N28R2-A-007-NNNN	420	5.5	26	16.2	120	28.2	B	490	270	400	13
HLR01.1N-01K6-N18R0-A-007-NNNU	109	1.6	34	3.3	120	20	A	185	649	120	5.2
HLR01.1N-03K5-N19R0-A-007-NNNN	252	3.5	31	8	120	21.3	B	300	270	490	9.5
HLR01.1N-04K5-N18R0-A-007-NNNN	432	4.5	33	13	120	20.2	B	400	270	490	13
HLR01.1N-06K5-N18R0-A-007-NNNN	686	6.5	33	21	120	20.2	B	400	270	490	13
HLR01.1N-10K0-N18R0-A-007-NNNN	1,080	10	33	32	120	20.2	B	600	270	490	22
HLR01.1N-02K0-N15R0-A-007-NNNU	137	2	40	3.4	120	16.7	A	185	749	120	6.2
HLR01.1N-05K0-N15R0-A-007-NNNN	360	5	40	9	120	16.9	B	400	270	490	13
HLR01.1N-07K0-N14R0-A-007-NNNN	672	7	43	16	120	15.7	B	600	270	490	22
HLR01.1N-09K5-N13R0-A-007-NNNN	1,003	9.5	46	22	120	14.6	B	600	270	490	22
HLR01.1N-14K5-N13R0-A-007-NNNN	1,566	14.5	46	34	120	14.6	B	800	270	490	33
HLR01.1N-04K5-N07R4-A-007-NNNN	246	4.5	81	3	120	8.3	B	300	270	490	9.5
HLR01.1N-08K5-N08R0-A-007-NNNN	612	8.5	75	8.2	120	9	B	600	270	490	22
HLR01.1N-11K0-N07R3-A-007-NNNN	1,056	11	82	13	120	8.2	B	600	270	490	22
HLR01.1N-15K0-N08R1-A-007-NNNN	1,584	15	74	21	120	9.1	B	800	270	490	33
HLR01.1N-24K0-N07R2-A-007-NNNN	2,592	24	83	31	120	8.1	C	795	710	490	80
HLR01.1N-06K5-N06R1-A-007-NNNN	356	6.5	98	3.6	120	6.9	B	400	270	490	13
HLR01.1N-12K5-N05R5-A-007-NNNN	900	12.5	109	8.3	120	6.2	B	800	270	490	33
HLR01.1N-17K0-N05R1-A-007-NNNN	1,632	17	117	14	120	5.7	B	1,000	270	490	43
HLR01.1N-23K0-N05R5-A-007-NNNN	2,429	23	109	22	120	6.2	C	595	710	490	56
HLR01.1N-36K0-N05R4-A-007-NNNN	3,888	36	111	35	120	6.1	C	995	710	490	93

Please see the selection tables on the end of this chapter for exact assignments to the power units.

# Brake units – for HMV power supply units and HCS converters

The connection of brake units increases the continuous and peak regenerative power.

The brake unit also makes it possible to have the DC bus short circuit function available in the drive system.

This function makes it possible to brake the synchronous motors even in the event of a power failure.

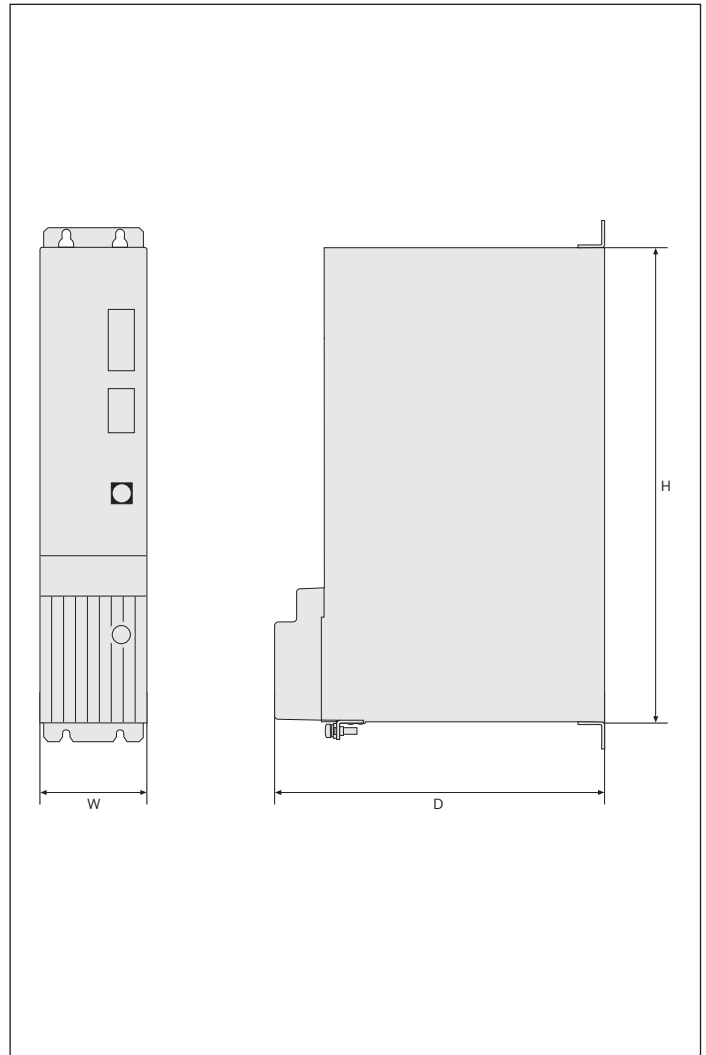

Brake unit	Maximum energy consumption	Braking power				Width W	Height H	Depth D	Weight
		Duration	Max.	t <sub>on time</sub>	t <sub>cycle time</sub>				
kWs	kW	kW	s	s	mm	mm	mm	kg	
HLB01.1C-01K0-N06R0-A-007-NNNN	100	1	100	1	100	65	352	252	5.8
HLB01.1D-02K0-N03R4-A-007-NNNN	500	2	180	2.7	250	100	440	309	12.2

Please see the selection tables on the end of this chapter for exact assignments to the power units.

# Capacity modules – for HMV power supply units and HCS converters

Capacity modules improve the energy balance in applications where machining cycles take place in rapid succession, such as roll feeds or cross cutting lines. Connected to the DC bus, the capacity modules act as a temporary energy storage unit and reduce the heat loss in the control cabinet by relieving the braking resistor. In the event of a power failure the reserve energy enables a controlled retraction motion. This protects the workpiece and the tool, e.g. in gear cutting machines.

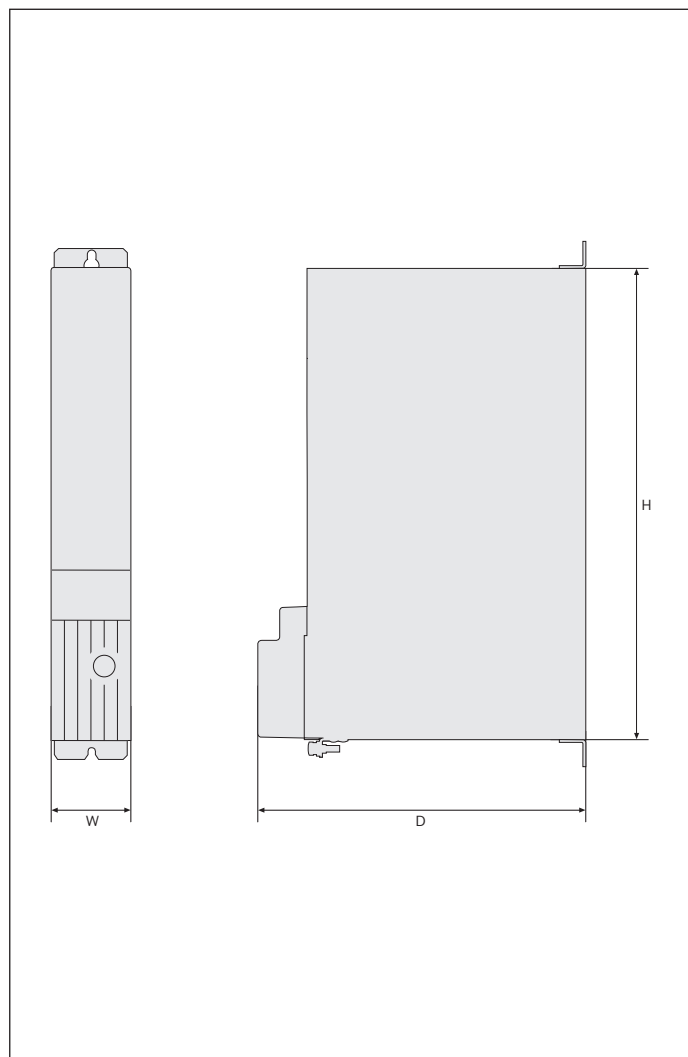

Capacity modules	Capacitance	Width W	Height H	Depth D	Weight
	mF	mm	mm	mm	kg
HLC01.1C-01M0-A-007-NNNN	1	50	352	251.5	3.2
HLC01.1C-02M4-A-007-NNNN	2.4	50	352	251.5	4.3
HLC01.1D-05M0-A-007-NNNN	5	75	440	309	8.6

Please see the selection tables on the end of this chapter for exact assignments to the power units.

## Blower units – for HMV supply units and HMS inverters

The blower unit HAB01 is required for operating the supply unit HMV01.1R-W0120 and the inverter HMS01.1N-W0350. In a space-saving arrangement, it is mounted directly below the unit. The electrical connection is made via a simple plug-in connector.

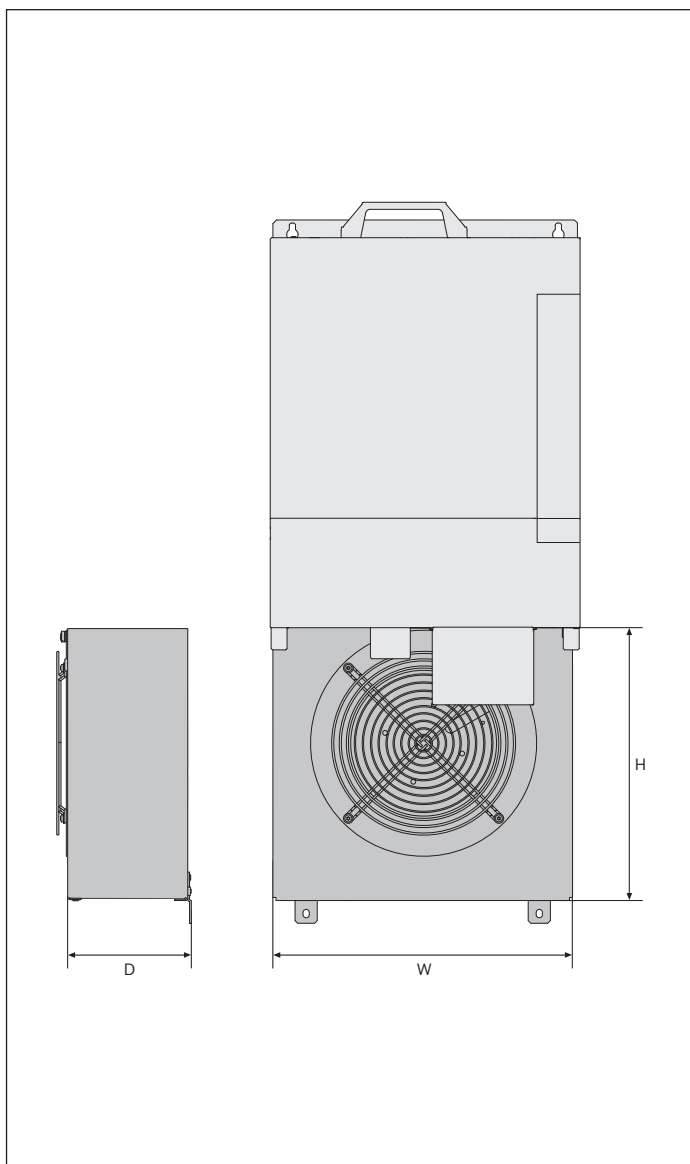
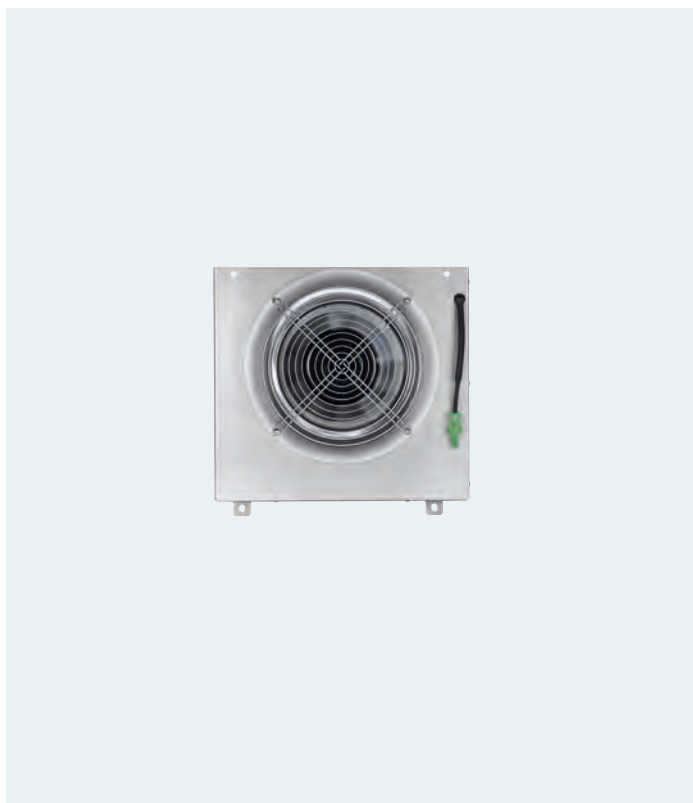

Blower unit	Width W	Height H	Depth D	Weight
	mm	mm	mm	kg
HAB01.1-0350-1640-NN	350	308	152	7.5

# Other accessories

## Basic accessories HAS01

The basic accessories contain all the mounting parts and fixing elements. Depending on the application, we supply these accessories complete with all the connecting bars for control voltage and DC bus.

## Shield connection HAS02

The shield connection plate is an EMC-compatible method of connecting the motor cable to your control unit. It also serves as a cord grip.

## Control cabinet adapter HAS03

The control cabinet adapters are used to combine HCS02 converters and their auxiliary components with units from the IndraDrive M series. Spacer bolts even out the lower unit depth thus creating an even frontage with a uniform installation height.

## Auxiliary capacitor HAS04

Use the additional capacitor HAS04 to operate HCS02 and HCS03 inverters with an HNF mains filter even if the minimum number of attached control units is not reached.

## Flange assembly kit HAS07

In the case of HCS04 converters which are installed with the HAS07 flange-mounting kit, the heat sinks are located outside the control cabinet. This reduces the air conditioning of the control cabinet interior to a minimum.

## Control cabinet assembly kit HAS08

This assembly kit makes it easy to install the HCS04 converter in a Rittal TS8 control cabinet.

## Module bus extension RKB0001

All the control units are fitted with a bus cable to transmit the control signals. Where there are relatively large distances between individual control units we can supply the necessary module bus extensions, in various lengths ranging from 0.5 m to 40 m.

## Electrical adapters HAS05

---

HAS05.1-001 Use the HAS05.1-001 adapter to connect a HNK mains filter or a HMF motor filter to an HCS03.1E-W0070 converter.

---

HAS05.1-002 If you install both a mains filter and motor filter, please use the HAS05.1-002-NNN-NN adapter.

---

HAS05.1-003 You can use the HAS05.1-003 signal level converter to adjust the voltage level (5 – 30 V) of the encoder emulation signals to your application. The signal level converter is connected to the D-SUB connector of the control unit.

---

HAS05.1-004 You can use the HAS05.1-004 DC bus adapter to supply power to inverter units without using the standard connecting bars. Cables with a cross-section of up to 2 x 50 mm<sup>2</sup> per phase can be used.

---

HAS05.1-005 The HAS05.1-005 interface converter enables you to add RS485 connectivity to your IndraDrive. Pre-assembled cables are available to connect the level converter to the RS232 port of the control unit. The converters can either be clipped on to a DIN rail or attached directly to the mounting plate.

---

# Auxiliary components – cross reference

Components	HMV01.1E-W0030	HMV01.1E-W0075	HMV01.1E-W0120	HMV01.1R-W0018	HMV01.1R-W0045	HMV01.1R-W0065	HMV01.1R-W0120	HMV02.1R-W0015	HCS02.1E-W0012	HCS02.1E-W0028	HCS02.1E-W0054	HCS02.1E-W0070	HCS03.1E-W0070	HCS03.1E-W0100	HCS03.1E-W0150	HCS03.1E-W0210	HCS04.2E-W0350	HCS04.2E-W0420	HCS04.2E-W0520	HCS04.2E-W0640	HCS04.2E-W0790	HCS04.2E-W1010	HCS04.2E-W1240	HCS04.2E-W1540
<b>Mains filter HNF</b>																								
HNF01.1A-F240-E0051-A-480-NNNN	①											⑤ <sup>2)</sup>	⑤ <sup>2)</sup>											
HNF01.1A-M900-E0051-A-480-NNNN	②								④ <sup>1)</sup>	④ <sup>1)</sup>	④ <sup>2)</sup>	④ <sup>2)</sup>	④ <sup>2)</sup>											
HNF01.1A-F240-E0125-A-480-NNNN		①												⑤ <sup>2)</sup>	⑤ <sup>2)</sup>									
HNF01.1A-M900-E0125-A-480-NNNN		②												④ <sup>2)</sup>	④ <sup>2)</sup>									
HNF01.1A-F240-E0202-A-480-NNNN			①													⑤ <sup>2)</sup>								
HNF01.1A-M900-E0202-A-480-NNNN			②													④ <sup>2)</sup>								
HNF01.1A-F240-R0026-A-480-NNNN				①					⑤ <sup>1)</sup>	⑤ <sup>1)</sup>	⑤ <sup>2)</sup>													
HNF01.1A-M900-R0026-A-480-NNNN				②					④ <sup>1)</sup>	④ <sup>1)</sup>	④ <sup>2)</sup>													
HNF01.1A-F240-R0065-A-480-NNNN					①																			
HNF01.1A-M900-R0065-A-480-NNNN					②																			
HNF01.1A-F240-R0094-A-480-NNNN						①																		
HNF01.1A-M900-R0094-A-480-NNNN						②																		
HNF01.1A-H350-R0180-A-480-NNNN							③																	
HNF01.1A-H350-R0180-A-480-NNNN																								
HNF01.1B-A100-E0300-N-480-NNNN																⑧	⑧							
HNF01.1B-A100-E0580-N-480-NNNN																		⑧	⑧	⑧		⑧ <sup>3)</sup>	⑧ <sup>3)</sup>	
HNF01.1B-A100-E0740-N-480-NNNN																						⑧		
<b>Mains filter HNS</b>																								
HNS02.1A-Q200-R0023-A-480-NNNN							④ <sup>1)</sup>																	
<b>Mains filter NFD03</b>																								
NFD03.1-480-007									⑦ <sup>1)</sup>															
NFD03.1-480-016									⑦ <sup>1)</sup>	⑦ <sup>1)</sup>														
NFD03.1-480-030									⑦ <sup>1)</sup>	⑦ <sup>1)</sup>	⑦ <sup>2)</sup>	⑦ <sup>2)</sup>												
NFD03.1-480-055									⑦ <sup>1)</sup>	⑦ <sup>1)</sup>	⑦ <sup>2)</sup>	⑦ <sup>2)</sup>	⑨											
NFD03.1-480-075									⑦ <sup>1)</sup>	⑦ <sup>1)</sup>	⑦ <sup>2)</sup>	⑦ <sup>2)</sup>		⑨ <sup>4)</sup>										
NFD03.1-480-130															⑨									
NFD03.1-480-180																⑨								

①18/280; ②40/1050; ③8/350; ④12/200; ⑤6/240; ⑥12/200; ⑦6/120; ⑧1/75; ⑨1/5

Notes: 18/280 = mains filter for up to 18 drives and a maximum total motor cable length of 280 m. These values must be reviewed for each application. Additional components may be necessary. Regardless of the number of axes, the effective total mains current must not exceed the maximum current rating of the mains filter.

The maximum length might be different in case of open-loop mode or when using unshielded cables.

- 1) Recommended values for group supply without DC bus connection, the maximum cable length for single drives is 75 m.
- 2) Recommended values for central supply: one inverter supplies power to other inverters, the maximum cable length for single drives is 75 m.
- 3) 2 mains filters HNF are required for operation.
- 4) Reduce nominal current to 75 A

Components	HMV01.1E-W0030	HMV01.1E-W0075	HMV01.1E-W0120	HMV01.1R-W0018	HMV01.1R-W0045	HMV01.1R-W0065	HMV01.1R-W0120	HMV02.1R-W0015	HCS02.1E-W0012	HCS02.1E-W0028	HCS02.1E-W0054	HCS02.1E-W0070	HCS03.1E-W0070	HCS03.1E-W0100	HCS03.1E-W0150	HCS03.1E-W0210
<b>Mains filter with integrated HNK mains choke</b>																
HNK01.1A-A075-E0050-A-500-NNNN																1/75
HNK01.1A-A075-E0080-A-500-NNNN																1/75
HNK01.1A-A075-E0106-A-500-NNNN																1/75
HNK01.1A-A075-E0146-A-500-NNNN																1/75

Notes: 1/75 = mains filter for one drive, maximum motor cable length 75 m. These values must be reviewed for each application. Additional components may be necessary. The effective mains current must not exceed the maximum current rating of the mains filter. The maximum length might be different in case of open-loop mode or when using unshielded cables.



Components	HMV01.1E-W0030	HMV01.1E-W0075	HMV01.1E-W0120	HMV01.1R-W0018	HMV01.1R-W0045	HMV01.1R-W0065	HMV01.1R-W0120	HMV02.1R-W0015	HCS01.1E-W0028	HCS02.1E-W0012	HCS02.1E-W0028	HCS02.1E-W0054	HCS02.1E-W0070	HCS03.1E-W0070	HCS03.1E-W0100	HCS03.1E-W0150	HCS03.1E-W0210	HCS04.2E-W0350	HCS04.2E-W0420	HCS04.2E-W0520	HCS04.2E-W0640	HCS04.2E-W0790	HCS04.2E-W1010	HCS04.2E-W1240	HCS04.2E-W1540
<b>Motor filter HMF</b>																									
HMF01.1N-N0K2-M0012-A-500-NNNN										•	•														
HMF01.1N-N0K2-M0028-A-500-NNNN												•	•												
HMF01.1A-N0K2-D0045-A-500-NNNN													•												
HMF01.1A-N0K2-D0073-A-500-NNNN														•											
HMF01.1A-N0K2-D0095-A-500-NNNN															•										
HMF01.1A-N0K2-D0145-A-500-NNNN																•									
HMF01.1N-N0K1-M0320-N-690-NNNN																	•		•						
HMF01.1N-N0K1-M0480-N-690-NNNN																		•		•					
HMF01.1N-N0K1-M0760-N-690-NNNN																					•		•		
HMF01.1N-N0K1-M1190-N-690-NNNN																								•	•

Components	HMV01.1E-W0030	HMV01.1E-W0075	HMV01.1E-W0120	HMV01.1R-W0018	HMV01.1R-W0045	HMV01.1R-W0065	HMV01.1R-W0120	HMV02.1R-W0015	HCS01.1E-W0028	HCS02.1E-W0012	HCS02.1E-W0028	HCS02.1E-W0054	HCS02.1E-W0070	HCS03.1E-W0070	HCS03.1E-W0100	HCS03.1E-W0150	HCS03.1E-W0210	HCS04.2E-W0350	HCS04.2E-W0420	HCS04.2E-W0520	HCS04.2E-W0640	HCS04.2E-W0790	HCS04.2E-W1010	HCS04.2E-W1240	HCS04.2E-W1540
<b>Mains choke HNL</b>																									
HNL01.1E-0400-N0051-A-480-NNNN	•																								
HNL01.1E-0200-N0125-A-480-NNNN		•																							
HNL01.1E-0100-N0202-A-480-NNNN			•																						
HNL01.1R-0980-C0026-A-480-NNNN				•																					
HNL01.1R-0590-C0065-A-480-NNNN					•																				
HNL01.1R-0540-C0094-A-480-NNNN						•																			
HNL01.1R-0300-C0180-A-480-NNNN							•																		
HNL01.1E-1000-N0012-A-500-NNNN									•	•	•														
HNL01.1E-1000-N0020-A-500-NNNN												•													
HNL01.1E-0600-N0032-A-500-NNNN													•												
HNL01.1E-0571-N0050-A-500-NNNN														•											
HNL01.1E-0362-N0080-A-500-NNNN															•										
HNL01.1E-0240-N0106-A-500-NNNN																•									
HNL01.1E-0170-N0146-A-500-NNNN																	•								
HNL02.1R-0980-C0023-A-480-NNNN								•																	
HNL01.1E-0098-N0280-N-690-NNNN																		•							
HNL01.1E-0085-N0315-N-690-NNNN																			•						
HNL01.1E-0066-N0365-N-690-NNNN																				•					
HNL01.1E-0060-N0475-N-690-NNNN																					•				
HNL01.1E-0038-N0650-N-690-NNNN																						•			
HNL01.1E-0032-N0760-N-690-NNNN																							•		
HNL01.1E-0038-N0540-N-690-NNNN																								• <sup>1)</sup>	
HNL01.1E-0026-N0620-N-690-NNNN																									• <sup>1)</sup>

The effective total mains current of your application must not exceed the maximum rated current of the mains choke.

• Standard version <sup>1)</sup> 2 mains chokes HNL are required for operation.

# Auxiliary components – cross reference

Components	HMV01.1E-W0030	HMV01.1E-W0075	HMV01.1E-W0120	HMV01.1R-W0018	HMV01.1R-W0045	HMV01.1R-W0065	HMV01.1R-W0120	HMV02.1R-W0015	HCS01.1E-W0028	HCS02.1E-W0012	HCS02.1E-W0028	HCS02.1E-W0054	HCS02.1E-W0070	HCS03.1E-W0070	HCS03.1E-W0100	HCS03.1E-W0150	HCS03.1E-W0210	HCS04.2E-W0350	HCS04.2E-W0420	HCS04.2E-W0520	HCS04.2E-W0640	HCS04.2E-W0790	HCS04.2E-W1010	HCS04.2E-W1240	HCS04.2E-W1540
<b>DC choke HLL</b>																									
HLL01.1A-150U-N0290-C-008-0471-NNNN																		●							
HLL01.1A-138U-N0558-C-008-0558-NNNN																			●						
HLL01.1A-105U-N0486-C-008-0760-NNNN																				●					
HLL01.1A-095U-N0574-C-008-0840-NNNN																					●				
HLL01.1A-069U-N0702-C-008-1116-NNNN																						●			
HLL01.1A-063U-N0861-C-008-1260-NNNN																							●		
HLL01.1A-037U-N1160-C-008-1884-NNNN																								●	
HLL01.1A-034U-N1404-C-008-2232-NNNN																									●

Components	HCS02.1E-W0054	HCS02.1E-W0070	HCS03.1E-W0070	HCS03.1E-W0100	HCS03.1E-W0150	HCS03.1E-W0210	HCS04.2E-W0350	HCS04.2E-W0420	HCS04.2E-W0520	HCS04.2E-W0640	HCS04.2E-W0790	HCS04.2E-W1010	HCS04.2E-W1240	HCS04.2E-W1540
<b>Brake resistor HLR</b>														
HLR01.1N-01K8-N40R0-A-007-NNNN	○													
HLR01.1N-03K8-N40R3-A-007-NNNN	○													
HLR01.1N-02K4-N28R0-A-007-NNNN		○												
HLR01.1N-05K5-N28R2-A-007-NNNN		○												
HLR01.1N-0300-N17R5-A-007-NNNN			●											
HLR01.1N-01K6-N18R0-A-007-NNNU			○											
HLR01.1N-03K5-N19R0-A-007-NNNN			○											
HLR01.1N-04K5-N18R0-A-007-NNNN			○											
HLR01.1N-06K5-N18R0-A-007-NNNN			○											
HLR01.1N-10K0-N18R0-A-007-NNNN			○											
HLR01.1N-0470-N11R7-A-007-NNNN				●										
HLR01.1N-02K0-N15R0-A-007-NNNU				○										
HLR01.1N-05K0-N15R0-A-007-NNNN				○										
HLR01.1N-07K0-N14R0-A-007-NNNN				○										
HLR01.1N-09K5-N13R0-A-007-NNNN				○										
HLR01.1N-14K5-N13R0-A-007-NNNN				○										
HLR01.1N-0780-N07R0-A-007-NNNN					●									
HLR01.1N-04K5-N07R4-A-007-NNNN					○									
HLR01.1N-08K5-N08R0-A-007-NNNN					○									
HLR01.1N-11K0-N07R3-A-007-NNNN					○									
HLR01.1N-15K0-N08R1-A-007-NNNN					○									
HLR01.1N-24K0-N07R2-A-007-NNNN					○									
HLR01.1N-1K08-N05R0-A-007-NNNN						●								
HLR01.1N-06K5-N06R1-A-007-NNNN						○								
HLR01.1N-12K5-N05R5-A-007-NNNN						○								
HLR01.1N-17K0-N05R1-A-007-NNNN						○								
HLR01.1N-23K0-N05R5-A-007-NNNN						○								
HLR01.1N-36K0-N05R4-A-007-NNNN						○								

● Standard version ○ Heavy-duty version

Components	HCS02.1E-W0054	HCS02.1E-W0070	HCS03.1E-W0070	HCS03.1E-W0100	HCS03.1E-W0150	HCS03.1E-W0210	HCS04.2E-W0350	HCS04.2E-W0420	HCS04.2E-W0520	HCS04.2E-W0640	HCS04.2E-W0790	HCS04.2E-W1010	HCS04.2E-W1240	HCS04.2E-W1540
<b>Brake resistor for lifting gears</b>														
HLR01.1N-44k0-N03R3-B-007-NNNN							●			● <sup>1)</sup>				
HLR01.1N-66k0-N02R1-B-007-NNNN								●	●		● <sup>1)</sup>	● <sup>1)</sup>	● <sup>2)</sup>	● <sup>2)</sup>
<b>Brake resistor for running gears</b>														
HLR01.1N-22k0-N03R5-B-007-NNNN							●	● <sup>1)</sup>	● <sup>1)</sup>	● <sup>1)</sup>	● <sup>2)</sup>	● <sup>2)</sup>	● <sup>3)</sup>	● <sup>4)</sup>

● Standard version <sup>1)</sup> 2 brake resistors HLR are required for operation. <sup>2)</sup> 3 brake resistors HLR are required for operation.  
<sup>3)</sup> 4 brake resistors HLR are required for operation. <sup>4)</sup> 5 brake resistors HLR are required for operation.

Components	HMV01.1E-W0030	HMV01.1E-W0075	HMV01.1E-W0120	HMV01.1R-W0018	HMV01.1R-W0045	HMV01.1R-W0065	HMV01.1R-W0120	HMV02.1R-W0015	HMS01.1N-W0020	HMS01.1N-W0036	HMS01.1N-W0054	HMS01.1N-W0070	HMS01.1N-W0110	HMS01.1N-W0150	HMS01.1N-W0210	HMS01.1N-W0300	HMS01.1N-W0350	HMS02.1N-W0028	HMS02.1N-W0054	HMD01.1N-W0012	HMD01.1N-W0020	HMD01.1N-W0036	HCS02.1E-W0012	HCS02.1E-W0028	HCS02.1E-W0054	HCS02.1E-W0070	HCS03.1E-W0070	HCS03.1E-W0100	HCS03.1E-W0150	HCS03.1E-W0210	HCS04.2E-W0350	HCS04.2E-W0420	HCS04.2E-W0520	HCS04.2E-W0640	HCS04.2E-W0790	HCS04.2E-W1010	HCS04.2E-W1240	HCS04.2E-W1540												
<b>Brake unit HLB</b>																																																		
HLB01.1C-01K0-N06R0-A-007-NNNN	○	○	○	○	○	○	○	●																●	●	●	○	○	○	○																				
HLB01.1D-02K0-N03R4-A-007-NNNN	●	●	●	●	●	●	●																		○	○	○	●	●	●	●																			
<b>Brake chopper HLT</b>																																																		
HLT01.1A-200K-N-007-NNNN																																								●	●									
HLT01.1A-400K-N-007-NNNN																																											●	●	●					
<b>Capacity module HLC</b>																																																		
HLC01.1C-01M0-A-007-NNNN	○	○	○	○	○	○	○	●																	●	●	●																							
HLC01.1C-02M4-A-007-NNNN	○	○	○	○	○	○	○	●																	●	●	●																							
HLC01.1D-05M0-A-007-NNNN	●	●	●	●	●	●	●																		○	○	○																							
<b>Basic accessories HAS01</b>																																																		
HAS01.1-050-072-MN								●	●										●	●	●																													
HAS01.1-065-072-CN																																																		
HAS01.1-065-NNN-CN																																																		
HAS01.1-075-072-MN																																																		
HAS01.1-100-072-MN																																																		
HAS01.1-105-072-CN																																																		
HAS01.1-105-NNN-CN																																																		
HAS01.1-125-072-CN																																																		
HAS01.1-125-072-MN																																																		
HAS01.1-125-NNN-CN																																																		
HAS01.1-150-072-MN		●						●																																										
HAS01.1-150-NNN-MN		●																																																
HAS01.1-150-NNN-M2																																																		
HAS01.1-175-072-MN																																																		
HAS01.1-175-NNN-MN																																																		
HAS01.1-200-072-MN																																																		
HAS01.1-225-072-CN																																																		
HAS01.1-225-NNN-CN																																																		
HAS01.1-250-072-MN																																																		
HAS01.1-250-NNN-MN																																																		
HAS01.1-350-072-MN																																																		
HAS01.1-350-NNN-CN																																																		
HAS01.1-350-NNN-MN																																																		

● Standard version ○ With control cabinet adapter HAS03 to even out the different unit depths

# Auxiliary components – cross reference

Components	HMS01.1N-W0020	HMS01.1N-W0036	HMS01.1N-W0054	HMS01.1N-W0070	HMS01.1N-W0110	HMS01.1N-W0150	HMS01.1N-W0210	HMS01.1N-W0300	HMS01.1N-W0350	HMS02.1N-W0028	HMS02.1N-W0054	HMD01.1N-W0012	HMD01.1N-W0020	HMD01.1N-W0036	HCS02.1E-W0012	HCS02.1E-W0028	HCS02.1E-W0054	HCS02.1E-W0070	HCS03.1E-W0070	HCS03.1E-W0100	HCS03.1E-W0150	HCS03.1E-W0210	HNK01.1A...E0050	HNK01.1A...E0080	HNK01.1A...E0106	HNK01.1A...E0146	KCU02.1N
------------	----------------	----------------	----------------	----------------	----------------	----------------	----------------	----------------	----------------	----------------	----------------	----------------	----------------	----------------	----------------	----------------	----------------	----------------	----------------	----------------	----------------	----------------	------------------	------------------	------------------	------------------	----------

**Shield connection HAS02**

HAS02.1-001-NNN-NN	•	•	•	•																								
HAS02.1-002-NNN-NN												•	•	•	•	•	•	•	•									
HAS02.1-003-NNN-NN					•	•	•	•																				
HAS02.1-004-NNN-NN																				•								
HAS02.1-005-NNN-NN																					•							
HAS02.1-006-NNN-NN																						•						
HAS02.1-007-NNN-NN																							•		•	•		
HAS02.1-008-NNN-NN																						•						
HAS02.1-009-NNN-NN																												
HAS02.1-010-NNN-NN																												
HAS02.1-011-NNN-NN																												•
HAS02.1-014-NNN-NN										•																		
HAS02.1-015-NNN-NN																												•

Components	HCS02.1E-W0012	HCS02.1E-W0028	HCS02.1E-W0054	HCS02.1E-W0070	HLB01.1C	HLC01.1C
------------	----------------	----------------	----------------	----------------	----------	----------

**Control cabinet adapter HAS03**

HAS03.1-002-NNN-NN	•	•				•
HAS03.1-004-NNN-NN				•	•	

Components	HCS02.1E-W0012	HCS02.1E-W0028	HCS02.1E-W0054	HCS02.1E-W0070	HCS03.1E-W0070	HCS03.1E-W0100	HCS03.1E-W0150	HCS03.1E-W0210
------------	----------------	----------------	----------------	----------------	----------------	----------------	----------------	----------------

**Auxiliary capacitor HAS04**

HAS04.1-001-NNN-NN		•	•	•				
HAS04.1-002-NNN-NN					•	•	•	•

Only required in combination with mains filter HNF or if power is supplied to other HMS01 inverters.

Components	HMV01.1E-W0030	HMV01.1E-W0075	HMV01.1E-W0120	HMV01.1R-W0018	HMV01.1R-W0045	HMV01.1R-W0065	HMV01.1R-W0120	HMV02.1R-W0015	HMS01.1N-W0020	HMS01.1N-W0036	HMS01.1N-W0054	HMS01.1N-W0070	HMS01.1N-W0110	HMS01.1N-W0150	HMS01.1N-W0210	HMS01.1N-W0300	HMS01.1N-W0350	HMS02.1N-W0028	HMS02.1N-W0054	HMD01.1N-W0012	HMD01.1N-W0020	HMD01.1N-W0036
------------	----------------	----------------	----------------	----------------	----------------	----------------	----------------	----------------	----------------	----------------	----------------	----------------	----------------	----------------	----------------	----------------	----------------	----------------	----------------	----------------	----------------	----------------

**Adapter HAS05 – DC bus connection**

HAS05.1-004-NNL-NN	•	•	•	•	•	•	•	•	•	•	•	•	•	•	•	•	•	•	•	•	•	•	•
HAS05.1-004-NNR-NN	•	•	•	•	•	•	•	•	•	•	•	•	•	•	•	•	•	•	•	•	•	•	•

Components	BASIC OPEN LOOP	BASIC ANALOG	BASIC PROFIBUS	BASIC SERCOS	BASIC UNIVERSAL single-axis	BASIC UNIVERSAL double-axis	ADVANCED
	CSB01.1N-FC	CSB01.1N-AN	CSB01.1N-PB	CSB01.1N-SE	CSB01.1C	CDB01.1C	CSH01.1C

**Adapter HAS05 – signal level converter**

HAS05.1-003-NNN-NN		•			• <sup>1)</sup>	• <sup>1)</sup>	• <sup>1)</sup>
--------------------	--	---	--	--	-----------------	-----------------	-----------------

**Adapter HAS05 – RS232/485 converter**

HAS05.1-005-NNN-NN	•	•	•	•	•	•	•
--------------------	---	---	---	---	---	---	---

• Standard version <sup>1)</sup> For control units with MEM encoder emulation only <sup>2)</sup> For control units with safety option (L1, S1)

Components	BASIC OPEN LOOP	BASIC ANALOG	BASIC PROFIBUS	BASIC SERCOS	BASIC UNIVERSAL single-axis	BASIC UNIVERSAL double-axis	ADVANCED
	CSB01.1N-FC	CSB01.1N-AN	CSB01.1N-PB	CSB01.1N-SE	CSB01.1C	CDB01.1C	CSH01.1C

**Adapter HAS05 – from D-SUB 9-pin connector (X41) to the terminal**

HAS05.1-007-NNN-NN		● <sup>2)</sup>	● <sup>2)</sup>	● <sup>2)</sup>	● <sup>2)</sup>	● <sup>2)</sup>	● <sup>2)</sup>
--------------------	--	-----------------	-----------------	-----------------	-----------------	-----------------	-----------------

● Standard version <sup>1)</sup> For control units with MEM encoder emulation only <sup>2)</sup> For control units with safety option (L2, S2)

Components	HCS03.1E-W0070 with HMF motor filter	HCS03.1E-W0070 with HNK mains filter	HCS03.1E-W0070 with HMF motor filter and HNK mains filter
	<b>Adapter HAS05 – connection accessories</b>		
HAS05.1-001-NNN-NN	●	●	●
HAS05.1-002-NNN-NN			●

Components	HCS04.2E- W0350	HCS04.2E- W0420	HCS04.2E- W0520	HCS04.2E- W0640	HCS04.2E- W0790	HCS04.2E- W1010	HCS04.2E- W1240	HCS04.2E- W1540
	<b>Flange assembly kit HAS07</b>							
HAS07.1-350-NNN-NN	●							
HAS07.1-330-NNN-NN		●						
HAS07.1-430-NNN-NN			●					
HAS07.1-585-NNN-NN				● <sup>1)</sup>	● <sup>1)</sup>			

● Standard version <sup>1)</sup> When an external brake chopper HLT is used, the additional flange assembly kit HAS07.1-660-NNN-NN is required.

Components	HCS04.2E- W0350	HCS04.2E- W0420	HCS04.2E- W0520	HCS04.2E- W0640	HCS04.2E- W0790	HCS04.2E- W1010	HCS04.2E- W1240	HCS04.2E- W1540
	<b>Control cabinet assembly kit HAS08 for Rittal TS8, protection category IP23<sup>1)</sup></b>							
HAS08.1-002-P23-NN	●							
HAS08.1-003-P23-NN		●						
HAS08.1-004-P23-NN			●					
HAS08.1-005-P23-NN				●	●			
HAS08.1-006-P23-NN						●	●	
HAS08.1-007-P23-NN								●
<b>Control cabinet assembly kit HAS08 for Rittal TS8, protection category IP54 with filter fan<sup>2)</sup></b>								
HAS08.1-002-P54-FL	●							
HAS08.1-003-P54-FL		●						
HAS08.1-004-P54-FL			●					
HAS08.1-005-P54-FL				●	●			
HAS08.1-006-P54-FL						●	●	
HAS08.1-007-P54-FL								●
<b>Control cabinet assembly kit HAS08 for Rittal TS8, protection category IP54 with separate air guidance<sup>3)</sup></b>								
HAS08.1-002-P54-GL	●							
HAS08.1-003-P54-GL		●						
HAS08.1-004-P54-GL			●					
HAS08.1-005-P54-GL				●	●			
HAS08.1-006-P54-GL						●	●	
HAS08.1-007-P54-GL								●

● Standard version <sup>1)</sup> Prepared for mains choke HNL or DC choke HLL

<sup>2)</sup> Only with mains choke HNL <sup>3)</sup> Only with DC choke HLL

# Auxiliary components – connection cables

Motor	Power unit	Power cable	Extension
MSK030B-0900	HCS01.1E-W0003		
MSK030C-0900	HCS01.1E-W0005	RKL0014	
MSK040B-0450, -0600	HCS01.1E-W0008		
MSK040C-0450, -0600	HCS01.1E-W0018	RKL0019	
MSK043C-0600	HCS01.1E-W0028		
MSK050B-0300, -0450, -0600	HCS01.1E-W0054	RKL0053	
MSK050C-0300, -0450, -0600	HCS02.1E-W0012		
MSK060B-0300, -0600	HCS02.1E-W0028		
MSK060C-0300, -0600	HMD01.1N-W0012		
MSK061B-0300	HMD01.1N-W0020		
MSK061C-0200, -0300, -0600	HMD01.1N-W0036	RKL4302	RKL4305
MSK076C-0300, -0450	HMS01.1N-W0020		
	HMS01.1N-W0036		
	HMS02.1N-W0028		
	HCS02.1E-W0054		
	HCS02.1E-W0070		
	HCS03.1E-W0070	RKL4303	
	HMS01.1N-W0054		
	HMS01.1N-W0070		
	HMS02.1N-W0054		
MSK070C-0150, -0300, -0450	HCS01.1E-W0003		
MSK070D-0150, -0300	HCS01.1E-W0005	RKL0016	
MSK070E-0150, -0300	HCS01.1E-W0008		
MSK071C-0200, -0300, -0450	HCS01.1E-W0018		
MSK071D-0200, -0300, -0450	HCS01.1E-W0028	RKL0017	
MSK071E-0200, -0300	HCS01.1E-W0054	RKL0050	
MSK075C-0200, -0300, -0450	HCS02.1E-W0012		
MSK075D-0200, -0300	HCS02.1E-W0028		
MSK075E-0200, -0300	HMD01.1N-W0012		
	HMD01.1N-W0020		
	HMD01.1N-W0036	RKL4306	RKL4311
	HMS01.1N-W0020		
	HMS01.1N-W0036		
	HMS02.1N-W0028		
	HCS02.1E-W0054		
	HCS02.1E-W0070		
	HCS03.1E-W0070	RKL4307	
	HMS01.1N-W0054		
	HMS01.1N-W0070		
	HMS02.1N-W0054		

Motor	Power unit	Power cable	Extension
MSK070D-0450	HCS01.1E-W0018		
MSK070E-0450	HCS01.1E-W0028	RKL0018	
MSK071E-0450	HCS01.1E-W0054	RKL0052	
MSK075D-0450	HCS02.1E-W0012		
MSK075E-0450	HCS02.1E-W0028		
MSK103A-0300	HMD01.1N-W0012		
MSK103B-0300	HMD01.1N-W0020		
	HMD01.1N-W0036		
	HMS01.1N-W0020		
	HMS01.1N-W0036		
	HMS02.1N-W0028		
	HCS02.1E-W0054		
	HCS02.1E-W0070		
	HCS03.1E-W0070	RKL4309	
	HMS01.1N-W0054		
	HMS01.1N-W0070		
	HMS02.1N-W0054		
	HCS03.1E-W0100		
	HCS03.1E-W0150		
	HMS01.1N-W0110		
	HMS01.1N-W0150	RKL4310	
	HMS01.1N-W0210		
MSK103D-0300	HCS01.1E-W0054	RKL0058	
	HCS02.1E-W0012		
	HCS02.1E-W0028		
	HMD01.1N-W0012		
	HMD01.1N-W0020		
	HMD01.1N-W0036	RKL4313	
	HMS01.1N-W0020		
	HMS01.1N-W0036		
	HMS02.1N-W0028		
	HCS02.1E-W0054		
	HCS02.1E-W0070		
	HCS03.1E-W0070	RKL4314	
	HMS01.1N-W0054		
	HMS01.1N-W0070		
	HMS02.1N-W0054		
	HCS03.1E-W0100		
	HCS03.1E-W0150		
	HMS01.1N-W0110	RKL4315	
	HMS01.1N-W0150		
	HMS01.1N-W0210		
MSK100A-0200, -0300, -0450	HCS01.1E-W0054	RKL0054	
MSK100B-0200	HCS02.1E-W0012		
MSK100D-0200	HCS02.1E-W0028		
MSK101C-0200	HMD01.1N-W0012		
	HMD01.1N-W0020		
	HMD01.1N-W0036	RKL4325	
	HMS01.1N-W0020		
	HMS01.1N-W0036		
	HMS02.1N-W0028		
	HCS02.1E-W0054		
	HCS02.1E-W0070		
	HCS03.1E-W0070	RKL4320	
	HMS01.1N-W0054		
	HMS01.1N-W0070		
	HMS02.1N-W0054		

Motor	Power unit	Power cable	Extension
MSK100B-0300	HCS01.1E-W0054	RKL0051	
MSK100C-0200, -0300	HCS02.1E-W0012	RKL4326	RKL4336
MSK100D-0300	HCS02.1E-W0028		
MSK101D-0200	HMD01.1N-W0012		
	HMD01.1N-W0020		
	HMD01.1N-W0036		
	HMS01.1N-W0020		
	HMS01.1N-W0036		
	HMS02.1N-W0028	RKL4321	RKL4336
	HCS02.1E-W0054		
	HCS02.1E-W0070		
	HCS03.1E-W0070		
	HMS01.1N-W0054		
	HMS01.1N-W0070	RKL4343	RKL4336
	HMS02.1N-W0054		
	HCS03.1E-W0100		
	HCS03.1E-W0150		
	HMS01.1N-W0110	RKL4343	RKL4336
	HMS01.1N-W0150		
	HMS01.1N-W0210		
MSK100B-0400	HCS01.1E-W0054	RKL0056	
MSK100B-0450	HCS02.1E-W0012	RKL4327	RKL4337
MSK101C-0300, -0450	HCS02.1E-W0028		
	HMD01.1N-W0012		
	HMD01.1N-W0020		
	HMD01.1N-W0036		
	HMS01.1N-W0020		
	HMS01.1N-W0036		
	HMS02.1N-W0028	RKL4322	RKL4337
	HCS02.1E-W0054		
	HCS02.1E-W0070		
	HCS03.1E-W0070		
	HMS01.1N-W0054		
	HMS01.1N-W0070	RKL4322	RKL4337
	HMS02.1N-W0054		
	HCS03.1E-W0100		
	HCS03.1E-W0150		
MSK100C-0450	HCS01.1E-W0054	RKL0055	
MSK100D-0350	HCS02.1E-W0054	RKL4323	RKL4338
MSK101D-0300	HCS02.1E-W0070		
MSK101E-0200	HCS03.1E-W0070		
MSK131B-0200	HMS01.1N-W0054		
	HMS01.1N-W0070		
	HMS02.1N-W0054		
	HCS03.1E-W0100		
	HCS03.1E-W0150	RKL4328	RKL4338
	HMS01.1N-W0110		
	HMS01.1N-W0150		
	HMS01.1N-W0210		

Motor	Power unit	Power cable	Extension
MSK101D-0450	HCS02.1E-W0054	RKL4324	RKL4339
MSK101E-0300	HCS02.1E-W0070		
	HCS03.1E-W0070		
	HMS01.1N-W0054		
	HMS01.1N-W0070		
	HMS02.1N-W0054		
	HCS03.1E-W0100		
	HCS03.1E-W0150	RKL4329	RKL4339
	HMS01.1N-W0110		
	HMS01.1N-W0150		
	HMS01.1N-W0210		
MSK101E-0450	HCS02.1E-W0054	RKL4344	RKL4340
MSK131D-0200	HCS02.1E-W0070		
	HCS03.1E-W0070		
	HMS01.1N-W0054		
	HMS01.1N-W0070		
	HMS02.1N-W0054		
	HCS03.1E-W0100		
	HCS03.1E-W0150	RKL4330	RKL4340
	HMS01.1N-W0110		
	HMS01.1N-W0150		
	HMS01.1N-W0210		
	HMS01.1N-W0300	RKL4349	RKL4340
	HCS03.1E-W0210		
	HMS01.1N-W0350	RKL4783 <sup>1)</sup>	RKL4342 <sup>1)</sup>
MSK133B-0202-SA	HCS03.1E-W0150	RKL4775	RKL4340
MSK133B-0203-FN	HMS01.1N-W0150		
	HMS01.1N-W0210		
	HMS01.1N-W0300		
	HCS03.1E-W0210	RKL4787	
MSK133C-0202-SA	HCS03.1E-W0150	RKL4727	See documentation "Connection cables – selection data"
MSK133C-0203-FN	HMS01.1N-W0150		
	HMS01.1N-W0210		
	HMS01.1N-W0300		
	HCS03.1E-W0210	RKL4728	
MSK133D-0202-SA	HMS01.1N-W0210	RKL4729	RKL4340
MSK133E-0202-SA	HMS01.1N-W0300		
	HCS03.1E-W0210	RKL4730	
MSK133D-0203-FN	HCS03.1E-W0100	2 x RKL4727	RKL4340
MSK133E-0203-FN	HCS03.1E-W0150		
	HMS01.1N-W0110		
	HMS01.1N-W0150		
	HMS01.1N-W0210		
	HMS01.1N-W0300		
	HCS03.1E-W0210		

These tables are an extract from our extensive range of cables.  
Cables for other motors can be found in our documentation entitled  
"Connection cables – selection data".

All specifications given apply to motors with natural convection at 60K.  
Standard encoder cable RKG4200 for all motors.

<sup>1)</sup> For surface-cooled motor

# Glossary

## ► A

### **ADVANCED**

Control units for maximum performance and dynamics with many configuration options

## ► B

### **BASIC**

Control units for standard applications

### **Basic accessories**

All the mounting parts and hardware, and the connecting bars for the control voltage and DC bus

### **Brake chopper**

#### **Brake transistor**

Transistor which switches a brake resistor on and off

### **Braking power**

Power which is recovered in regenerative operation of the motors

### **Brake resistor**

For input power in regenerative operation (converted into heat)

### **Brake unit**

All-in-one unit comprising brake resistor and braking transistor (brake chopper) used to increase the braking power

## ► C

### **Capacity module**

Optional auxiliary component to store energy in the DC bus

### **CLOSED LOOP**

Closed control loop (automatically regulated operation) in which the device being regulated is monitored using a measuring system and made available to the drive

### **Control cabinet adapter**

Spacer bolts used to even out different unit depths

### **Control unit**

The part of the drive unit comprising all the control functions and interfaces for installation in the power unit

### **Converter**

Takes the mains voltage with its fixed amplitude and frequency and generates a three-phase alternating current with variable amplitude and frequency

## ► D

### **DC bus voltage**

DC voltage generated from the AC network and used to supply the power units

### **Derating**

Lowering of the specified data in the event of a change in operating conditions

### **Drive unit**

Converter and inverter consisting of a power and a control unit, for the control of servo and standard motors.

## ► E

### **EMC**

Electromagnetic compatibility

### **Encoder cable**

Cable used to connect the motor encoder to the encoder interface of the control unit

## ► F

### **Firmware**

Device-specific software for the drive functions

### **Functions library**

Collection of function blocks conforming to IEC or PLCopen

## ► I

### **IndraDrive C**

Compact drive series, converters

### **IndraDrive Cs**

Ultra-compact, multi-protocol-capable drive series, inverters

### **IndraDrive M**

Modular drive series, inverters and power supply units

### **IndraDrive Mi**

Cabinet-free drive technology – inverter, control unit and synchronous servo motor in one unit

### **IndraDyn A**

Air-cooled or liquid-cooled asynchronous servo motors

### **IndraDyn H**

High-speed frameless (kit) motors

### **IndraDyn L**

Synchronous linear motors

### **IndraDyn S**

Synchronous servo motors, also for potentially explosive areas

### **IndraDyn T**

Synchronous frameless (kit) torque motors

### **IndraMotion MLD**

Integrated automation solution comprising drive functions, motion control and processing logic

### **IndraSize**

Software tool used for sizing and selecting drives based on the machine data

### **IndraWorks**

Engineering framework toolkit for project planning, parameterization, start-up, diagnostics, etc.

### **Inverter**

Takes the DC bus voltage and generates a three-phase alternating current with variable amplitude and frequency



► **M****Mains choke**

Used to increase the continuous DC bus output and to suppress harmonics

**Mains filter**

EMC filter for power supply units and converters used to reduce circuit feedback

**Module bus**

Bus connection between power units for exchanging internal control signals

**Module bus extension**

Optional bus connection used to bridge larger than average distances between individual drive control units

**Motion logic**

Integrated automation solution comprising drive functions, motion control and processing logic

**Motor filter**

Used to protect the motor winding from extreme voltage rises

**Multi-Ethernet**

General term for various Ethernet-based communications protocols (sercos III, PROFINET IO, EtherNet/IP, EtherCAT) that are covered by a single multiprotocol-capable hardware device

► **O****OPEN LOOP**

Open control loop (controlled operation) in which the device being controlled is not monitored using measuring techniques

► **P****Power cable**

Cable for connecting the motor to the power unit

**Power recovery**

Return of energy to the mains supply during regenerative operation of the drive

**Power supply unit**

Takes the mains voltage with fixed amplitude and frequency and generates a DC bus voltage

**Power unit**

The part of the drive control unit containing the power electronics to control the motors, used to hold the control unit

► **S****Safety on Board**

Safety technology integrated in the drive, certified in accordance with EN 13849-1 and EN 62061

**sercos III**

Serial Real-time Communications Standard Interface – open and serial real-time communication standard for high-precision motion control applications, designed by leading manufacturers of numerically controlled drives

**Shield connection**

Connection plate for EMC-compatible connection of the motor cable to the control unit

**Software module**

MultiMedia Card for simple transmission of axis-oriented drive parameters without the use of a PC

**Switching frequency**

Clock frequency of the pulse width modulation (PWM)

► **T****Technology package**

Process-oriented function blocks, e.g. tension control

► **U****User library**

Collection of function blocks developed by the user

**User program**

Application-specific combination of different function blocks/technology packages

# Formulas

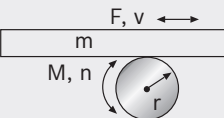
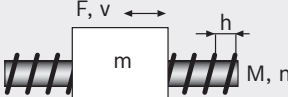
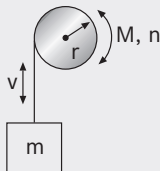
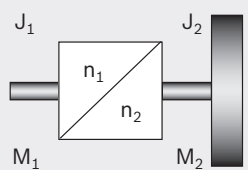
	Speed	Torque	Output	Mass moment of inertia
<p>Roller, wheel, pinion and belt drive</p> 	$n = \frac{v}{2 \cdot r \cdot \pi}$	$M = F \cdot r$	$P = \frac{F \cdot v}{60}$	$J = m \cdot r^2$
<p>Ball screw drive</p> 	$n = \frac{v \cdot 1000}{h}$	$M = \frac{F \cdot h}{2 \cdot \pi \cdot 1000}$	$P = \frac{F \cdot v}{60}$	$J = m \cdot \left( \frac{h}{2 \cdot \pi \cdot 1000} \right)^2$
<p>Pulley drive</p> 	$n = \frac{v}{2 \cdot \pi \cdot r}$	$M = m \cdot g \cdot r$	$P = \frac{m \cdot g \cdot v}{60}$	$J = m \cdot r^2$
	Speed	Torque	Transmission ratio	Mass moment of inertia
<p>Gear conversion</p> 	$n_1 = n_2 \cdot i$	$M_1 = \frac{M_2}{i}$	$i = \frac{n_1}{n_2}$	$J_1 = \frac{J_2}{i^2}$

## Miscellaneous

Rotational frequency	$\omega = \frac{2 \cdot \pi \cdot n}{60}$	Effective electrical power	$P = U \cdot I \cdot \cos\phi \cdot \sqrt{3}$
Rotational kinetic energy	$W = \frac{J \cdot \omega^2}{2}$	Apparent electrical power	$S = U \cdot I \cdot \sqrt{3}$
Translational kinetic energy	$W = \frac{m}{2} \cdot \frac{(v)^2}{(60)^2}$	Reactive electrical power	$Q = U \cdot I \cdot \sin\phi \cdot \sqrt{3}$
Synchronous rpm	$n = \frac{f \cdot 60}{p}$	DC bus voltage	$U = U_{\text{Netz}} \cdot \sqrt{2}$
Synchronous speed	$v = 2 \cdot f \cdot T_p \cdot 60$	Force	$F = m \cdot a$

## Unit conversion

Physical value	Name of unit	Conversion	Name of unit
Force	pound-force	1 lbf = 4.4482 N	Newton
Power	horsepower	1 hp = 745.7 W	Watt
Length	inch	1 in = 25.4 mm	millimeter
Length	foot	1 ft = 0.3048 m	meter
Weight	pound	1 lb = 0.4536 kg	kilogram

## Legend

a – Acceleration in ms <sup>-2</sup>	J – Mass moment of inertia in kgm <sup>2</sup>	r – Radius in m
F – Force in N	M – Torque in Nm	S – Apparent power in VA
f – Frequency in s <sup>-1</sup>	m – Weight in kg	U – Voltage in V
g – Gravitational acceleration 9.81 ms <sup>-2</sup>	n – Rotational speed in rpm	v – Speed in m/min
h – Spindle pitch in mm	P – Power in W	W – Energy in Ws
I – Current in A	p – Pole pair number	T <sub>p</sub> – Pole pitch in m
i – Transmission ratio	Q – Reactive power in var	ω – Rotational frequency in s <sup>-1</sup>

# Documentation and further information

IndraDrive  
Drive System, Project  
Planning Manual  
R911309635/DE  
R911309636/EN



IndraDrive Mi  
Configuration  
R911335702/DE  
R911335703/EN



IndraMotion MLD,  
Application Manual  
R911306071/DE  
R911306084/EN



IndraDrive  
Supply Units and  
Power Sections  
R911318789/DE  
R911318790/EN



IndraDrive  
Control Units, Project  
Planning Manual  
R911295011/DE  
R911295012/EN



IndraMotion MLD  
The First Steps  
Brief Description  
R911319304/DE  
R911319306/EN



IndraDrive HCS04,  
Project Planning  
Manual  
R911327333/DE  
R911327334/EN



IndraDrive  
Firmware Theory  
of Operation  
R911315484/DE  
R911315485/EN  
Parameter Description  
R911297316/DE  
R911297317/EN



IndraMotion MLD  
Libraries,  
Library Description  
R911308317/DE  
R911309224/EN



IndraDrive  
Additional Components  
R911306139/DE  
R911306140/EN



Safety Technology  
Application Manual  
R911327663/DE  
R911327664/EN



IndraLogic  
Programming  
Instructions  
R911305035/DE  
R911305036/EN



IndraDrive Cs,  
Project Planning  
Manual  
R911322209/DE  
R911322210/EN



IndraDrive Cs  
Application Manual  
R911326484/DE  
R911326767/EN  
Parameter Description  
R911328650/DE  
R911328651/EN



Troubleshooting  
Information  
R911297318/DE  
R911297319/EN



IndraDyn S (MSK)  
Project Planning  
R911296288/DE  
R911296289/EN  
IndraDyn S (MSK) for  
Hazardous Areas,  
Project Planning  
R911312708/DE  
R911312709/EN



IndraDyn T,  
Project Planning  
Manual  
R911291224/DE  
R911298798/EN



**Products online**

Information about IndraDrive and IndraDyn is available at [www.boschrexroth.com/electrics-catalog](http://www.boschrexroth.com/electrics-catalog)

**Documentation online**

Current documentation is also available at [www.boschrexroth.com/mediadirectory](http://www.boschrexroth.com/mediadirectory)

**Download CAD data**

Current CAD data is available at [www.boschrexroth.com/electrics-catalog](http://www.boschrexroth.com/electrics-catalog)

**Download IndraSize**

IndraSize – the drive sizing program can be downloaded at [www.boschrexroth.com/indrasize](http://www.boschrexroth.com/indrasize)

**Rexroth online**

Information about Bosch Rexroth AG and our products and system solutions can be found by visiting [www.boschrexroth.com](http://www.boschrexroth.com)

IndraDyn S (MKE)  
for Potentially  
Explosive Areas acc. to  
ATEX and UL/CSA  
R911297662/DE  
R911297663/EN



IndraDyn H  
Project Planning  
Manual  
R911297894/DE  
R911297895/EN



IndraDyn S (MSM)  
Data Sheet  
R911329337/DE  
R911329338/EN



1MB Frameless (Kit)  
Spindle Motors,  
Project Planning  
Manual  
R911263704/DE  
R911264277/EN



IndraDyn A,  
Project Planning  
Manual  
R911295054/DE  
R911295781/EN



GTE Gearboxes,  
Project Planning  
Manual  
R911308841/DE  
R911308842/EN  
GTM Gearboxes,  
Project Planning  
Manual  
R911297320/DE  
R911297321/EN



IndraDyn L (MLF),  
Project Planning  
Manual  
R911293634/DE  
R911293635/EN



IndraDrive and  
IndraDyn  
Connection Cables,  
Selection Data  
R911322948/DE  
R911322949/EN



IndraDyn L (MCL),  
Project Planning  
Manual  
R911330591/DE  
R911330592/EN

# Notes



**Bosch Rexroth AG**

Bgm.-Dr.-Nebel-Str. 2  
97816 Lohr, Germany  
Phone +49(0)9352/18-0  
Fax +49(0)9352/18-8400  
[www.boschrexroth.com/electrics](http://www.boschrexroth.com/electrics)

**Local contact information can be found at:**

[www.boschrexroth.com/contact](http://www.boschrexroth.com/contact)

The data specified above only serve to describe the product. As our products are constantly being further developed, no statements concerning a certain condition or suitability for a certain application can be derived from our information. The information given does not release the user from the obligation of own judgment and verification.

It must be remembered that our products are subject to a natural process of wear and aging.